

Thor™ VM1 Vehicle-Mount Computer

with Microsoft® Windows® Embedded Standard 2009

User's Guide

Disclaimer

Honeywell International Inc. (“HII”) reserves the right to make changes in specifications and other information contained in this document without prior notice, and the reader should in all cases consult HII to determine whether any such changes have been made. The information in this publication does not represent a commitment on the part of HII.

HII shall not be liable for technical or editorial errors or omissions contained herein; nor for incidental or consequential damages resulting from the furnishing, performance, or use of this material.

This document contains proprietary information that is protected by copyright. All rights are reserved. No part of this document may be photocopied, reproduced, or translated into another language without the prior written consent of HII.

© 2011-2014 Honeywell International Inc. All rights reserved.

Web Address: www.honeywellaidc.com

Trademarks

RFTerm is a trademark or registered trademark of EMS Technologies, Inc. in the United States and/or other countries.

Microsoft® Windows, ActiveSync®, MSN, Outlook®, Windows Mobile®, the Windows logo, and Windows Media are registered trademarks or trademarks of Microsoft Corporation.

Intel® and Atom™ are trademarks or registered trademarks of Intel Corporation or its subsidiaries in the United States and other countries.

Summit Data Communications, the Laird Technologies Logo, the Summit logo, and “Connected. No Matter What” are trademarks of Laird Technologies, Inc.

Wi-Fi®, WMM®, Wi-Fi Multimedia™, Wi-Fi Protected Access®, WPA™, WPA2™ and the Wi-Fi CERTIFIED™ logo are trademarks or registered trademarks of Wi-Fi Alliance.

The Bluetooth® word mark and logos are owned by the Bluetooth SIG, Inc.

Symbol® is a registered trademark of Symbol Technologies. MOTOROLA, MOTO, MOTOROLA SOLUTIONS and the Stylized M Logo are trademarks or registered trademarks of Motorola Trademark Holdings, LLC and are used under license.

Freefloat, Link*One and Access*One are trademarks of Freefloat, Mölndalsvägen 30B, SE-412 63Gothenburg, Sweden.

RAM® and RAM Mount™ are both trademarks of National Products Inc., 1205 S. Orr Street, Seattle, WA 98108.

Qualcomm® is a registered trademark of Qualcomm Incorporated. Gobi is a trademark of Qualcomm Incorporated.

Verizon® is a registered trademark of Verizon Trademark Services LLC.

T-MOBILE® is a registered trademark of Deutsche Telekom AG.

AT&T® is a registered trademark of AT&T Intellectual Property.

SD and SDHC are trademarks or registered trademarks of SD-3C, LLC in the United States, other countries or both.

SanDisk® and CompactFlash® are trademarks of SanDisk Corporation, registered in the United States and other countries.

Transcend® is a registered trademark of Transcend Information, Inc.

ATP is a trademark of ATP Electronics, Inc.

Acrobat® Reader © 2014 with express permission from Adobe Systems Incorporated.

Other product names or marks mentioned in this document may be trademarks or registered trademarks of other companies and are the property of their respective owners.

Patents

For patent information, please refer to www.hsmpats.com.



Table of Contents

Chapter 1 - Thor VM1 Agency Information

FCC Part 15 Statement.....	1-1
FCC 5GHz Statement.....	1-1
EMC Directive Requirements.....	1-1
Canada, Industry Canada (IC) Notices.....	1-1
COFETEL.....	1-2
ANATEL (Brazil).....	1-2
Vehicle Power Supply Connection Safety Statement.....	1-2
Li-Ion Battery.....	1-2
RF Safety Notice.....	1-3
Bluetooth.....	1-3
Honeywell Scanning & Mobility Product Environmental Information.....	1-3
CE Mark.....	1-3
Dealer License - Republic of Singapore.....	1-3

Chapter 2 - Getting Started

Overview.....	2-1
About this Guide.....	2-1
Out of the Box.....	2-1
Initial Setup for Thor VM1.....	2-2
Hardware Setup.....	2-2
Software.....	2-2
Languages.....	2-2
First Boot.....	2-2
Software Setup.....	2-2
Quick Mount Smart Dock.....	2-2
Components.....	2-3
Front View.....	2-3
Back View with Quick Mount Smart Dock.....	2-4
Access Panels.....	2-4
Backlights and Indicators.....	2-5
Display Backlight.....	2-5
Power Management.....	2-5
Backlight Brightness.....	2-5
Screen Blanking.....	2-5
Keypad Backlight.....	2-5
Speaker Volume.....	2-5
Power Up.....	2-6
Rebooting the Thor VM1.....	2-7
Restart.....	2-7
Tapping the Touch Screen with a Stylus.....	2-7
Setup Terminal Emulation Parameters.....	2-7
Cleaning the Touch Screen.....	2-8
Startup Help.....	2-8

Chapter 3 - Hardware Overview

System Hardware	3-1
802.11a/b/g/n Wireless Client.....	3-1
Central Processing Unit.....	3-1
Input/Output Components.....	3-1
System Memory.....	3-1
Video Subsystem.....	3-1
Audio Interface.....	3-1
Card Slots	3-2
CompactFlash (CF) Slot	3-2
Secure Digital (SD) Slot.....	3-2
Bluetooth EZPair.....	3-2
WWAN	3-2
GPS	3-2
Power	3-2
Vehicle DC Power Supply.....	3-2
External AC Power Supply	3-3
Uninterruptible Power Supply	3-3
Safe Charging Temperature Range.....	3-3
Charging Timeout	3-3
Charging and Power Management	3-3
Backup Battery	3-3
Fuse.....	3-4
Power Management Modes.....	3-4
Full On Mode	3-4
StandbyMode.....	3-4
Hibernate Mode	3-4
Off Mode.....	3-4
Power Controls	3-5
Power Switch	3-5
Power Button	3-5
Auto On Behavior	3-5
External Connectors	3-6
Serial Connector (COM1 and COM2).....	3-6
Screen Blanking.....	3-6
USB Connector.....	3-6
CANbus / Audio Connector.....	3-7
Power Supply Connector.....	3-7
Antenna Connections	3-8
External Antenna Connector.....	3-8
Internal 802.11 Antenna	3-8
Vehicle Remote Antenna	3-8
Keyboard Options.....	3-9
64-Key QWERTY Keyboard	3-9
IBM 3270 Overlay	3-9
IBM 5250 Overlay	3-10
Keypad LEDs.....	3-10
USB Keyboard / Mouse	3-10

LED Functions	3-10
System LEDs	3-10
SYS (System Status) LED	3-11
UPS Status LED	3-11
SSD (Solid State Drive) LED	3-11
Connection LEDs.....	3-12
WWAN LED	3-12
Wi-Fi LED	3-12
Bluetooth LED.....	3-12
Keyboard LEDs.....	3-13
2nd LED	3-13
Shift LEDs.....	3-13
Ctrl LED	3-13
Alt LED.....	3-13
Display	3-13
Touch Screen	3-13
Touch Screen Defroster.....	3-14
Screen Blanking.....	3-14
Display Backlight Control.....	3-14

Chapter 4 - Vehicle Mounting and Accessory Installation

Introduction.....	4-15
Prepare for Vehicle Mounting	4-15
Quick Start.....	4-15
Maintenance - Vehicle Mounted Devices	4-15
Cleaning	4-16
Place Thor VM1 in the Dock.....	4-16
Dock I/O Pin Cover.....	4-17
Padlock.....	4-17
Laptop Security Cable	4-17
Install RAM Mount	4-18
Components - RAM Mounting Kits	4-18
Procedure - RAM Mount Assembly	4-19
Torque Measurement	4-19
Step 1a – Attach RAM Ball to Vehicle	4-19
Step 1b – Mount RAM Clamp to Vehicle	4-20
Step 1c – Attach RAM Plate to Vehicle and Attach RAM Ball	4-21
Step 2 – Attach RAM Mount Ball to the Thor VM1 Quick Mount Smart Dock	4-22
Step 3 – Attach Thor VM1 Assembly to RAM Mount.....	4-23
Step 4 – Place the Thor VM1 into the Dock.....	4-23
Install U Bracket Mount	4-24
Components - U Bracket Mounting Assembly	4-24
Procedure - U Bracket Assembly.....	4-24
Torque Measurement	4-24
Mounting Positions	4-25
Step 1 - Install U Bracket to Vehicle	4-25
Step 2 - Remove RAM Ball.....	4-26
Step 3 - Attach Adapter Bracket	4-26

Connect Cables	4-27
Strain Relief Cable Clamps.....	4-27
Connect Power	4-28
Power Cable Cautions	4-28
12-48 VDC Vehicles (10-60 VDC Direct Connection).....	4-29
60-144 VDC Vehicles (50-150 VDC Power Supply, Screws on Side of Lid)	4-34
60-144 VDC Vehicles (50-150 VDC Power Supply, Screws on Top of Lid)	4-38
VX6 / VX7 Adapter Cable	4-42
Thor VX8 / Thor VX9 Adapter Cable	4-43
Screen Blanking.....	4-44
External AC/DC Power Supply	4-47
Connect USB Host.....	4-47
Connect USB Client.....	4-48
Connect Serial Device	4-48
Connect a Tethered Scanner.....	4-48
Connect Headset Cable.....	4-49
Adjust Headset / Microphone and Secure Cable.....	4-49
Connect CANbus Cable.....	4-50
Install Remote Antenna	4-51
802.11 Remote Mount Antenna.....	4-51
WAN Remote Mount Antenna	4-53
GPS Remote Mount Antenna	4-53
Apply Touch Screen Protective Film	4-54
Installation.....	4-54
Removal.....	4-54
Disconnect UPS Battery	4-55
Install SD Card	4-56
Install SIM Card	4-57
Replace Front Panel.....	4-58
Replace UPS Battery.....	4-60

Chapter 5 - Software

Microsoft Windows Setup and Configuration.....	5-1
Drive C Folder Structure	5-1
Software Loaded on Drive C.....	5-1
Control Panel.....	5-3
About	5-3
Software.....	5-3
Versions.....	5-3
Network IP	5-4
AutoOn.....	5-5
Standard	5-5
Ignition Control.....	5-5
Auto-On	5-5
Bluetooth.....	5-6
Bluetooth Devices.....	5-8
Discover.....	5-8
Settings.....	5-10

Reconnect.....	5-12
About	5-13
Using Bluetooth	5-14
Display	5-18
Power Options	5-19
Select a Power Scheme	5-19
View UPS Battery Status	5-20
Hibernate	5-22
Screen Control.....	5-23
Screen Blanking.....	5-24
Automatic Brightness Control	5-24
Current Level	5-24
Defroster Control	5-24
Screen Rotation	5-25
Sounds.....	5-25
System Rating (Windows Experience Index).....	5-26
Tablet PC Settings (Touch Screen Calibration).....	5-26
User Accounts	5-26
Wi-Fi	5-26
Bar Code Readers.....	5-27
Scanner Wedge	5-27
Touch Screen Calibration	5-27
BIOS	5-28
Accessing the BIOS Setup	5-28
Boot Order	5-28
Exiting BIOS Setup	5-28
Thor VM1 Recovery DVD	5-28
Upgrading the Thor VM1	5-28
Automatic Firmware Update Utility	5-29
Requirements	5-29
Firmware Distribution Files	5-29
Update Process	5-29
Configuration Cloning Utility (CCU)	5-30
Configuration Cloning Utility GUI	5-31
Menu Options	5-32
Shortcuts.....	5-34
Modifying Settings	5-35
Using the CCU.....	5-36
Configuration Cloning Utility Command Line Interface	5-37

Chapter 6 - Wireless Network Connections

Network Connections Control Panel.....	6-1
Summit Wireless Network Configuration	6-1
Important Notes	6-1
Summit Client Utility	6-1
Summit Tray Icon.....	6-1
Wireless Zero Config Utility	6-2
To Switch Control to the Wireless Zero Config Utility	6-2

To Switch Control to SCU	6-2
Main	6-3
Admin Login	6-3
Profile.....	6-5
Buttons.....	6-5
Profile Parameters	6-6
Status.....	6-8
Diags.....	6-9
Global	6-10
Custom Parameter Option	6-11
Global Parameters.....	6-11
Logon Options	6-13
Sign-On vs. Stored Credentials	6-15
To Use Stored Credentials	6-15
To Use Sign On Screen.....	6-16
To Use Windows Username and Password	6-16
Windows Certificate Store vs. Certs Path.....	6-17
User Certificates	6-17
Root CA Certificates	6-17
Certs Path.....	6-17
Windows Certificate Store	6-17
Configuring the Profile	6-18
No Security	6-19
WEP.....	6-20
LEAP.....	6-21
PEAP/MSCHAP	6-22
PEAP/GTC.....	6-24
WPA/LEAP	6-26
EAP-FAST	6-27
EAP-TLS.....	6-29
WPA PSK	6-31
Certificates.....	6-31
Generate a Root CA Certificate	6-32
Install a Root CA Certificate.....	6-33
Generate a User Certificate	6-34
Exporting a User Certificate.....	6-35
Install a User Certificate.....	6-36
Manually Initiate Certificate Installation	6-37
OneClick Internet.....	6-38
Preparing for Initial Use on the Thor VM1	6-38
Install SIM Card	6-38
Load Firmware.....	6-38
Activation	6-38
Using OneClick Internet.....	6-40
Connection Management.....	6-40
Menu Buttons.....	6-41
Radio Button	6-41
Statistics Button	6-41

Update Button	6-41
Help Button	6-41
Settings Button	6-42
Application Buttons	6-49
SMS	6-49
Web Browser	6-52
Email	6-52
GPS	6-52
About	6-53
System Requirements	6-53
OneClick Internet Connection Manager	6-55
Connection Management	6-56
Information Buttons	6-57

Chapter 7 - Key Maps

64-Key QWERTY Keypad Key Map	7-1
IBM Terminal Emulation	7-5
IBM 3270	7-5
IBM 5250	7-6

Chapter 8 - Specifications and Reference Material

Technical Specifications	8-1
Thor VM1	8-1
Quick Mount Smart Dock	8-1
Dimensions	8-2
Thor VM1	8-2
Quick Mount Smart Dock	8-2
Environmental Specifications	8-2
Thor VM1 and Quick Mount Smart Dock	8-2
Network Card Specifications	8-3
Summit 802.11 a/b/g/n	8-3
Bluetooth	8-3
WWAN	8-3
Port and Connector Pinouts	8-4
Power Supply Connector	8-4
COM1 and COM2 Connector	8-4
USB Connector	8-5
USB Y Cable	8-5
CANbus / Audio Connector	8-6
Headset Adapter Cable	8-6
CANbus Y Cable	8-7
Hat Encoding	8-8

Chapter 9 - Customer Support

Product Service and Repair	9-1
Technical Assistance	9-1
Limited Warranty	9-1



Thor VM1 Agency Information

Thor VM1 mobile computers meet or exceed the requirements of all applicable standards organizations for safe operation. However as with any electrical equipment, the best way to ensure safe operation is to operate them according to the agency guidelines that follow. Read these guidelines before using your Thor VM1.

This documentation is relevant for the following Thor models: VM1W.



RISK OF EXPLOSION IF BATTERY IS REPLACED BY AN INCORRECT TYPE. The battery should be disposed of by a qualified recycler or hazardous materials handler. Do not incinerate the battery or dispose of the battery with general waste materials.

FCC Part 15 Statement

This device complies with FCC Rules, part 15. Operation is subject to the following two conditions:

1. This device may not cause harmful interference, and
2. This device must accept any interference received, including interference that may cause undesired operation.

NOTE - This equipment has been tested and found to comply with the limits for a Class A digital device, pursuant to Part 15 of the FCC Rules. These limits are designed to provide reasonable protection against harmful interference when the equipment is operated in a commercial environment. This equipment generates, uses, and can radiate radio frequency energy and, if not installed and used in accordance with the instruction manual, may cause harmful interference to radio communications. Operation of this equipment in a residential area is likely to cause harmful interference in which case the user will be required to correct the interference at his own expense.

Caution - Changes or modifications made to this equipment not expressly approved by Honeywell may void the FCC authorization to operate this equipment.

FCC 5GHz Statement

LAN devices are restricted to indoor use only in the band 5150-5250 MHz.

For the band 5600-5650 MHz, no operation is permitted.



When using IEEE 802.11a wireless LAN, this product is restricted to indoor use, due to its operation in the 5.15- to 5.25-GHz Frequency range. The FCC requires this product to be used indoors for the frequency range of 5.15 GHz to 5.25 GHz to reduce the potential for harmful interference to co-channel mobile satellite systems. High-power radar is allocated as the primary user of the 5.25- to 5.35-GHz and 5.65- to 5.85-GHz bands. These radar stations can cause interference with and/or damage to this device.

EMC Directive Requirements

This is a Class A product. In a domestic environment this product may cause radio interference in which case the user may be required to take adequate measures.

Canada, Industry Canada (IC) Notices

This Class A digital apparatus complies with Canadian RSS-GEN issue 3:2010 and RSS-210 issue 8:2010.

Operation is subject to the following two conditions: (1) this device may not cause interference, and (2) this device must accept any interference, including interference that may cause undesired operation of the device.

Radio Frequency (RF) Exposure Information

The radiated output power of the Honeywell Thor VM1 is below the Industry Canada (IC) radio frequency exposure limits. The Honeywell Thor VM1 should be used in such a manner such that the potential for human contact during normal operation is minimized.

This device has been certified for use in Canada. Status of the listing in the Industry Canada's REL (Radio Equipment List) can be found at the following web address: Additional Canadian information on RF exposure also can be found at the following web address: Canada, avis d'Industry Canada (IC)

Cet appareil numérique de classe A est conforme aux normes canadiennes RSS-GEN numéro 3:2010 et RSS-210 numéro 8:2010.

Son fonctionnement est soumis aux deux conditions suivantes : (1) cet appareil ne doit pas causer d'interférence et (2) cet appareil doit accepter toute interférence, notamment les interférences qui peuvent affecter son fonctionnement.

Informations concernant l'exposition aux fréquences radio (RF)

La puissance de sortie émise par de le Honeywell Thor VM1 est inférieure à la limite d'exposition aux fréquences radio d'Industry Canada (IC). Utilisez le Honeywell Thor VM1 de façon à minimiser les contacts humains lors du fonctionnement normal.

Ce périphérique est homologué pour l'utilisation au Canada. Pour consulter l'entrée correspondant à l'appareil dans la liste d'équipement radio (REL - Radio Equipment List) d'Industry Canada rendez-vous sur: Pour des informations supplémentaires concernant l'exposition aux RF au Canada rendez-vous sur : ANATEL (Brazil)

Este equipamento opera em caráter secundário, isto é, não tem direito a proteção contra interferência prejudicial, mesmo de estações do mesmo tipo, e não causar interferência a sistema operando em caráter primário.

COFETEL

ANEXO CUMPLIMIENTO REGULATORIO NOM-121-SCT1-2009

EQUIPO: Terminal montada en vehículo

MARCA: Honeywell

MODELO: VM1 W

Para su uso en México, la operación de este equipo está sujeta a las siguientes dos condiciones: (1) es posible que este equipo o dispositivo no cause interferencia perjudicial y (2) este equipo o dispositivo debe aceptar cualquier interferencia, incluyendo la que pueda causar su operación no deseada.

Este equipo ha sido diseñado para operar con las antenas que enseguida se enlistan y para una ganancia máxima de antena de 2.0 y 1.0 dBi @ 2.4 GHz WLAN; 4.0 y 5.0 dBi @ 5 GHz WLAN; -1.5 dBi @ 2.4 GHz para Bluetooth. Siendo únicas las antenas con que cuenta la terminal. El uso con este equipo de antenas no incluidas en esta lista o que tengan una ganancia mayor que lo especificado quedan prohibidas. La impedancia requerida de la antena es de 50 ohms.1

Marca	Modelo	Tipo	Ganancia
LARSEN	R380500314	Dipolo, Banda Dual	2.0 y 1.0 dBi @ 2.4 GHz WLAN
LARSEN	R380500314	Dipolo, Banda Dual	4.0 y 5.0 dBi @ 5 GHz WLAN

ANATEL (Brazil)

Este equipamento opera em caráter secundário, isto é, não tem direito a proteção contra interferência prejudicial, mesmo de estações do mesmo tipo, e não causar interferência a sistema operando em caráter primário.

Vehicle Power Supply Connection Safety Statement

WARNING - For proper and safe installation, the input power cable must be connected to a fused circuit on the vehicle. If the supply connection is made directly to the battery, the fuse should be installed in the positive lead within 5 inches of the battery's positive (+) terminal. The fused circuit requires a maximum time delay (slow blow) fuse with a current rating as noted below.

- For **12VDC** input, use a 10A slow blow fuse that has a DC voltage rating greater than 12VDC.
- For **24VDC** input, use a 6A slow blow fuse that has a DC voltage rating greater than 24VDC.
- For **36VDC** input, use a 4A slow blow fuse that has a DC voltage rating greater than 36VDC.
- For **48VDC** input, use a 3A slow blow fuse that has a DC voltage rating greater than 48VDC.

Note: For North America, a UL Listed fuse is to be used

Li-Ion Battery

When disposing of the Thor VM1 UPS battery, the following precautions should be observed: The battery should be disposed of properly. The battery should not be disassembled or crushed. The battery should not be heated above 212°F (100°C) or incinerated.

Safety requirements restrict the temperature at which the Li-Ion UPS battery can be charged. Charging is disabled if the ambient temperature is outside of the 0°C to 35°C safe charging range. In order to maintain UPS charge the Thor VM1 should have power applied while the unit is within the safe charging range for at least an hour each day.

RF Safety Notice



This device is intended to transmit RF energy. For protection against RF exposure to humans and in accordance with FCC rules and Industry Canada rules, this transmitter should be installed such that a minimum separation distance of at least 20 cm (7.8 in.) is maintained between the antenna and the general population. This device can only be co-located with FCC ID:TWG-SDCPE15N.

Bluetooth



Honeywell Scanning & Mobility Product Environmental Information

Refer to www.honeywellaidc.com/environmental for the RoHS / REACH / WEEE information.

CE Mark

The CE marking on the product indicates that this device is in conformity with the following directives:

- 1995/5/EC R&TTE
- 2011/65/EU RoHS (Recast)

In addition, complies to 2006/95/EC Low Voltage Directive, when shipped with recommended power supply.

European contact:

Hand Held Products Europe BV
Nijverheidsweg 9-13
5627 BT Eindhoven
The Netherlands

Honeywell shall not be liable for use of our product with equipment (i.e., power supplies, personal computers, etc.) that is not CE marked and does not comply with the Low Voltage Directive.

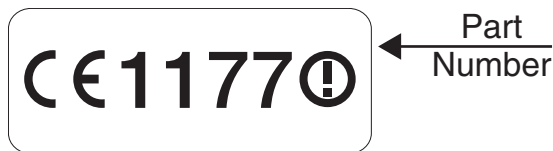

Dealer License - Republic of Singapore

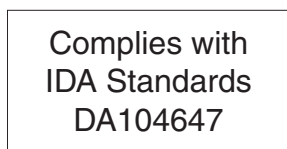

Republic of Singapore - Dealer License Number DA104647 complies with IDA Standards.

WWAN is not available in Singapore.



Getting Started

Overview

The Thor VM1 Vehicle Mount Computer (VMC) is a rugged, vehicle mounted computer running a Microsoft® Windows® Embedded Standard 2009 operating system and capable of wireless data communications from a fork-lift truck or any properly configured vehicle. Wireless communications are supported over a 802.11 WLAN network and, optionally, over a WWAN network. The Bluetooth® module supports Bluetooth printers and scanners.



CAUTION - Before shipping the Thor VM1, be sure to [Disconnect UPS Battery](#) (page 4-55) .

The Thor VM1 is designed for use with a vehicle Quick Mount Smart Dock. The dock installs in the vehicle and connects to vehicle power. The dock provides conditioned input power for the Thor VM1. Peripheral connections are on the dock. The Thor VM1 is designed to easily be removed from the dock with a latch on the lower rear of the Thor VM1 housing. Since the dock remains attached to the vehicle, the Thor VM1 computer can easily be moved from one vehicle equipped with a dock to another vehicle equipped with a dock.

The Thor VM1 contains a UPS battery which, when fully charged, can power the Thor VM1 for a minimum of 30 minutes. This can be when the Thor VM1 is not attached to a Quick Mount Smart Dock or when the Thor VM1 is attached to a dock but the vehicle power is interrupted, such as when the vehicle battery is being changed.

Contact [Technical Assistance](#) (page 9-1) for information on the latest upgrades for your Thor VM1.

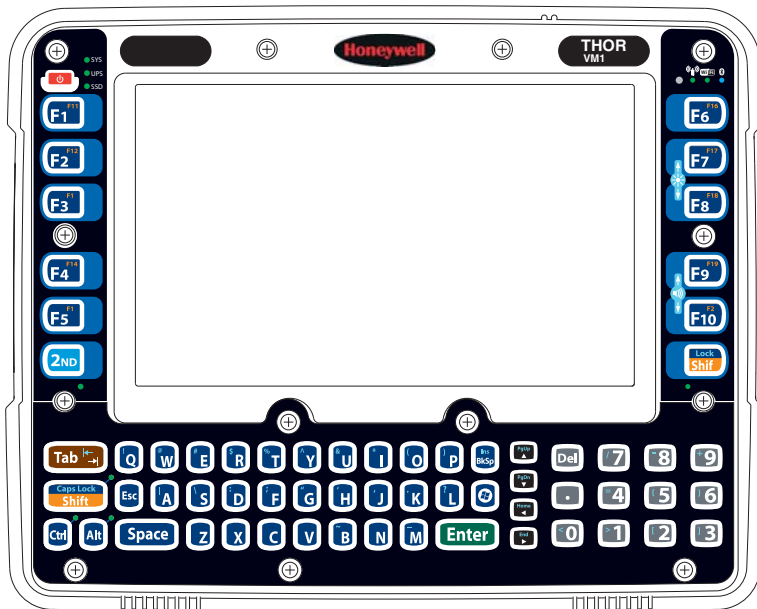

About this Guide

This user's guide has been developed for a Thor VM1 with a Microsoft® Windows® Embedded Standard 2009 operating system.

Out of the Box

The following items may be packaged separately:

- Thor VM1
- Quick Mount Smart Dock (includes 10-60VDC power cable)
- RAM or U-Bracket vehicle mount kit

If you ordered additional accessories for the Thor VM1, verify they are also included with the order. Keep the original packaging material in the event the Thor VM1 should need to be returned for service. For details, see [Product Service and Repair](#) (page 9-1).

Initial Setup for Thor VM1

This page lists a quick outline of the steps you might take when setting up a new Thor VM1. More instruction for each step is listed later in this guide.

Contact [Technical Assistance](#) (page 9-1) if you need additional help.

Hardware Setup

1. [Install RAM Mount](#) (page 4-18) or [Install U Bracket Mount](#) (page 4-24) to the vehicle.
2. [Place Thor VM1 in the Dock](#) (page 4-16).
3. [Connect Cables](#) (page 4-27) for any peripherals.
4. [Connect Power](#) (page 4-28).
5. Secure all cables in [Strain Relief Cable Clamps](#) (page 4-27).
6. Press the [Power Switch](#) (page 3-5) on the dock to the on position.
7. Press the [Power Button](#) (page 3-5) on the Thor VM1.

Software

Languages

The Thor VM1 may be shipped with an English only operating system. Contact [Technical Assistance](#) (page 9-1) to order a [Thor VM1 Recovery DVD](#) (page 5-27) in a different language. The language installed is identified on the **Software** tab of the [About](#) (see page 5-3) control panel.

First Boot

When a new Thor VM1 starts up a EULA (End User License Agreement) may be displayed on the touch screen. It remains on the screen until the Accept or Decline button is tapped with a stylus.

Tap the **Accept** button to accept the EULA terms and the Thor VM1 continues the startup process. The EULA is not presented to the user again.

Tap the **Decline** button to decline the EULA and the Thor VM1 reboots. It will continue to reboot until the **Accept** button is tapped with the stylus.

Software Setup

Hardware setup should be completed before starting software setup.

1. If prompted, perform [Touch Screen Calibration](#) (page 5-26).
2. [Select a Power Scheme](#) (page 5-18) and set timers.
3. Adjust [Speaker Volume](#) (page 2-5).
4. Pair [Bluetooth](#) (page 5-6) devices
5. Set Wireless client parameters using the [Summit Client Utility](#) (page 6-1).
6. Set terminal emulation parameters.

Quick Mount Smart Dock

The Thor VM1 assembly consists of two parts, the Thor VM1 computer and the Quick Mount Smart Dock.

The Thor VM1 contains an internal UPS battery that, once fully charged, powers the Thor VM1 for a minimum of 30 minutes when the unit is not mounted in the dock.

The dock provides:

- A mount for the Thor VM1 computer. The dock attaches to a vehicle via a RAM or U-bracket mount or to a RAM table stand for use in an office environment.
- Conditioned power for the Thor VM1. The dock accepts 10-60VDC power input directly or 50-150VDC power input with a DC/DC converter.
- COM1 and COM2 serial connections for a tethered scanner, printer, PC connection, etc.
- USB host connection via an adapter cable.
- CANbus connection via an adapter cable.
- Headset connection via an adapter cable. When a headset is not attached, the microphone and speakers on the Thor VM1 are active.
- Strain relief cable mounts.
- Mobility of the Thor VM1, since the dock remains attached to the vehicle the Thor VM1 computer can easily be moved from one vehicle equipped with a dock to another.

External antenna connectors may be present on the back of the Thor VM1. The connectors may include:

- 802.11 antenna connectors, used when the Thor VM1 is not equipped with internal antennas.
- External GPS antenna connector, when the Thor VM1 is equipped with GPS.
- External WWAN antenna connectors, when the Thor VM1 is equipped with WWAN. Optional WWAN radio (available in North America, Europe, New Zealand, and Australia only).

Components

Front View

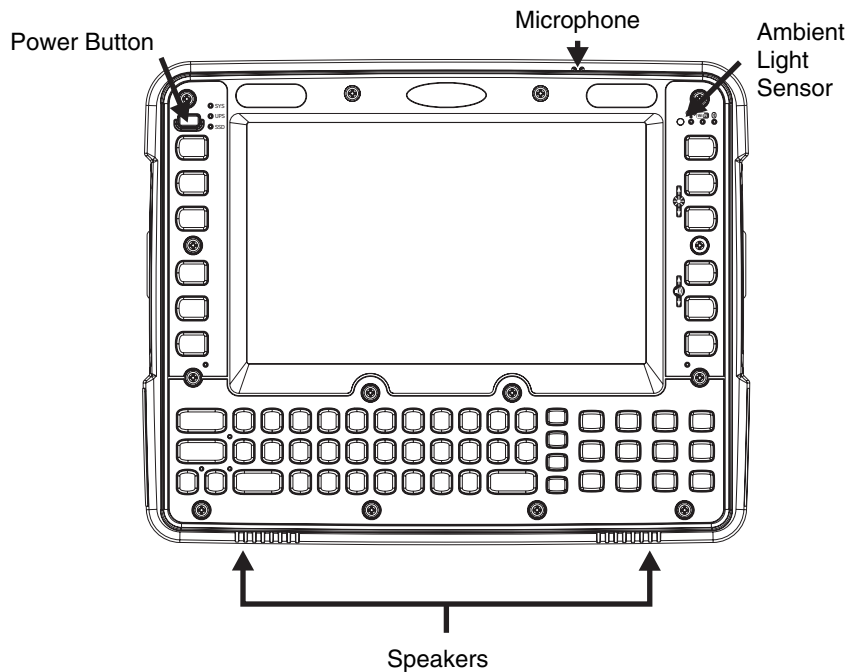

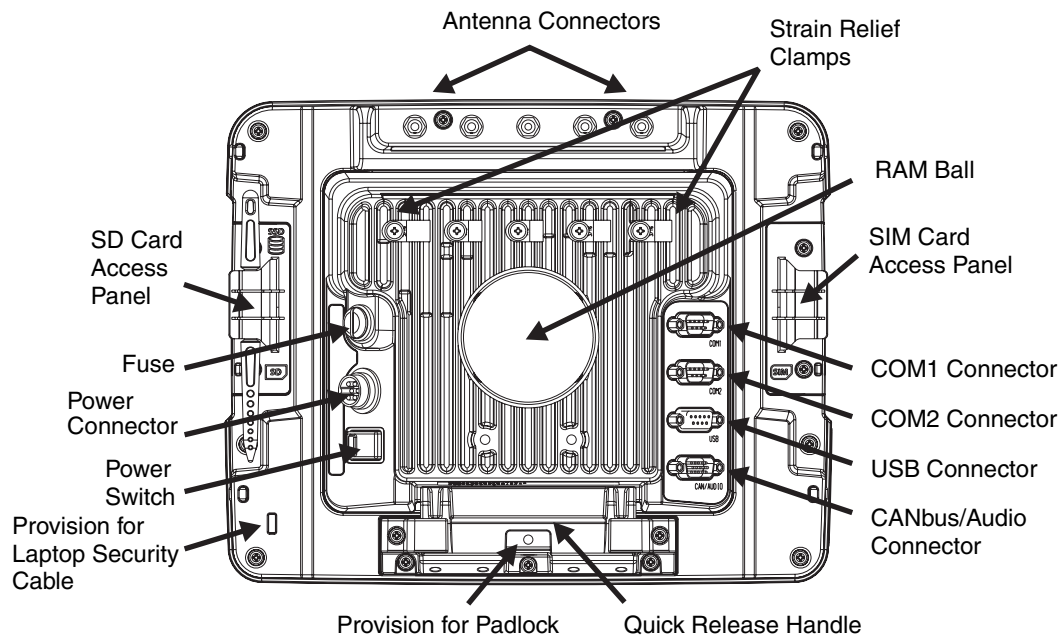

Back View with Quick Mount Smart Dock

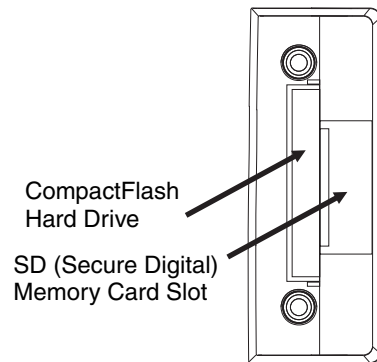

Access Panels

SD Card Access Panel with door removed



Access Panel Door is labeled with  and .

SIM Card Access Panel with door removed

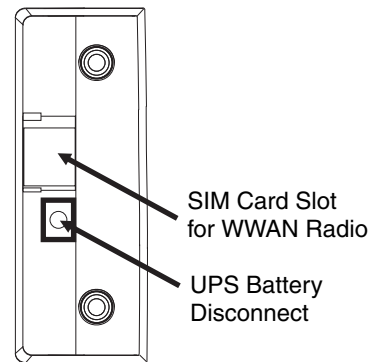

Access Panel Door is labeled with .

Backlights and Indicators

Display Backlight

There are several configuration options for the Thor VM1 display backlight:

Power Management

The display backlight is controlled by power management. When the user activity timer expires, the display backlight is turned off. Timeouts can be set for the available power management schemes.

See [Power Options](#) (page 5-18) for configuration options.

Backlight Brightness

The intensity of the display backlight can be manually configured:

- Use the **2nd + F7** keypress to increase backlight brightness or the **2nd + F8** keypress to decrease backlight brightness.

Refer to the [Screen Control](#) (page 5-22) panel for the current display brightness level.

Screen Blanking

The Thor VM1 can be configured to blank (blackout) the display while the vehicle is in motion.

Refer to the [Screen Control](#) (page 5-22) panel for information.

Keypad Backlight

The integrated keypad backlight follows the display backlight. If the display backlight is on, the keypad backlight is on.

Speaker Volume

The speaker volume can be adjusted via the Thor VM1 keypad:

- Use the **2nd + F9** keypress to increase speaker volume or the **2nd + F10** keypress to decrease speaker volume.

The current volume level can be viewed on the [Sounds](#) (page 5-24) control panel or via the system tray speaker icon. These items can also be used to adjust speaker volume

Power Up



If a USB drive, such as a thumb drive is attached to the Thor VM1, the device attempts to boot from the USB drive and cannot. Please remove the USB drive and power up the Thor VM1 again.

The Quick Mount Smart Dock has a power switch on the back.

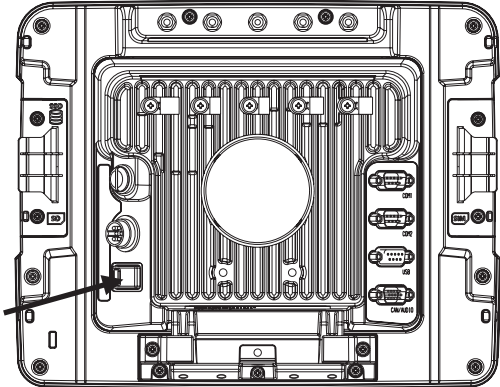

The “On” side of this rocker switch has a raised bump to allow the state of the switch to be determined when the switch may not be easily viewed, for example, after the dock is mounted in a vehicle.

After external power has been connected and the Thor VM1 has been mounted in the dock, press the side of the power switch with the raised bump to pass power from the dock to the Thor VM1.

Next locate the power button on the front of the Thor VM1.

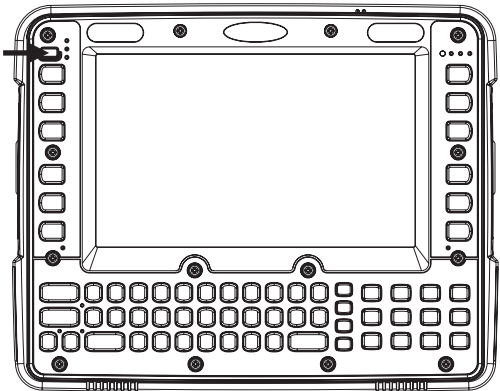

Press the power button to turn the Thor VM1 on. When the Windows desktop is displayed or an application begins, the power up sequence is complete.

See [Power Controls](#) (see page 3-5) for more information.

Rebooting the Thor VM1



If a USB drive, such as a thumb drive is attached to the Thor VM1, the device attempts to boot from the USB drive:

- If the USB drive contains a bootable sector, the Thor VM1 boots from the USB drive.
- If the USB drive does not contain a bootable sector, the Thor VM1 does not boot. Remove the USB drive and boot the Thor VM1 again.

Restart

Restart performs a controlled shutdown of the Thor VM1 and then restarts the device.

- Use the **Ctrl + Alt + Del** keypress sequence to start the task manager. Tap the **Shut Down** button and select **Restart** from the pull-down list. Tap the **OK** button to restart the Thor VM1..
- Select **Start > Shut Down > Restart** and tap OK to restart the Thor VM1

Tapping the Touch Screen with a Stylus

Note: Always use the point of the stylus for tapping or making strokes on the touch screen.

Never use an actual pen, pencil, or sharp/abrasive object to write on the touch screen.

Hold the stylus as if it were a pen or pencil. Touch an element on the screen with the tip of the stylus then remove the stylus from the screen.

Firmly press the stylus into the stylus holder when the stylus is not in use.

Using a stylus is similar to moving the mouse pointer then left-clicking icons on a desktop computer screen.

Using the stylus to tap icons on the touch screen is the basic action that can:

- Open applications
- Choose menu commands
- Select options in dialog boxes or drop-down boxes
- Drag the slider in a scroll bar
- Select text by dragging the stylus across the text
- Place the cursor in a text box prior to typing in data
- Place the cursor in a text box prior to retrieving data using a scanner/imager.



A right click is generated by tapping the mouse icon, usually located in the upper right hand corner of the screen. After tapping, the mouse icon highlights the right button. The next touch screen tap is treated as a right click. The mouse icon returns to the left button highlighted so subsequent taps are treated as left clicks.

*Note: If the mouse icon is not displayed, this feature can be enabled by tapping the PenMount icon  in the System Tray. From the menu that pops up, tap the **Right Button** to enable the mouse icon. When this option is enabled, a checkmark is displayed in the menu.*

A stylus replacement kit is available.

When a dialog box is too large for the display, tap and drag the dialog box up or down or from side to side to view the remainder of the dialog box.

Setup Terminal Emulation Parameters

Note: The instructions below are for Honeywell RFTerm. If a different terminal emulation software is installed on your Thor VM1 refer to the documentation for that software.

Before you make a host connection, you will, at a minimum, need to know:

- the alias name or IP address (Host Address) and
 - the port number (Telnet Port) of the host system to properly set up your host session.
1. Make sure the mobile client network settings are configured and functional. If you are connecting over wireless LAN (802.11x), make sure your mobile client is communicating with the Access Point.
 2. From **Start > Program**, run **RFTerm** or tap the RFTerm icon on the desktop.
 3. Select **Session > Configure** from the application menu and select the “host type” that you require. This will depend on the type of host system that you are going to connect to; i.e., 3270 mainframe, AS/400 5250 server or VT host.

4. Enter the “Host Address” of the host system that you wish to connect to. This may either be a **DNS name or an IP address of the host** system.
5. Update the **telnet port number**, if your host application is configured to listen on a specific port. If not, just use the default telnet port.
6. Select **OK**.
7. Select **Session > Connect** from the application menu or tap the “Connect” button on the Tool Bar. Upon a successful connection, you should see the host application screen displayed.

To change options such as Display, Colors, Cursor, Bar Code, etc., refer to these sections in the *RFTerm Reference Guide* for complete descriptions of these and other features.

Cleaning the Touch Screen

Note: These instructions are for components made of glass. If there is a removable protective film sheet on the display, remove the film sheet before cleaning the screen.

Keep fingers and rough or sharp objects away from the bar code reader scanning aperture and the mobile device touch screen.

If the glass becomes soiled or smudged, clean only with a standard household cleaner such as Windex[®] without vinegar or use isopropyl alcohol. Dampen the cloth with the cleaner and then wipe the surface.

Do not use paper towels or harsh-chemical-based cleaning fluids since they may result in damage to the glass surface. Use a clean, damp, lint-free cloth.

Do not scrub optical surfaces. If possible, clean only those areas which are soiled. Lint and particulates can be removed with clean, filtered canned air.

Startup Help

Contact [Technical Assistance](#) (page 9-1) if you need more help.

Touch screen is not accepting stylus taps or needs recalibration.	Press Ctrl+Esc to force the Start Menu to appear. Use the tab, backtab and arrow keys to move the cursor from element to element. See Touch Screen Calibration (page 5-26).
Thor VM1 seems to lockup as soon as it is rebooted.	There may be slight delays while the wireless client connects to the network, authorization for voice-enabled applications complete, and Bluetooth relationships establish or re-establish. When an application begins, the Thor VM1 is ready for use.

Hardware Overview

System Hardware

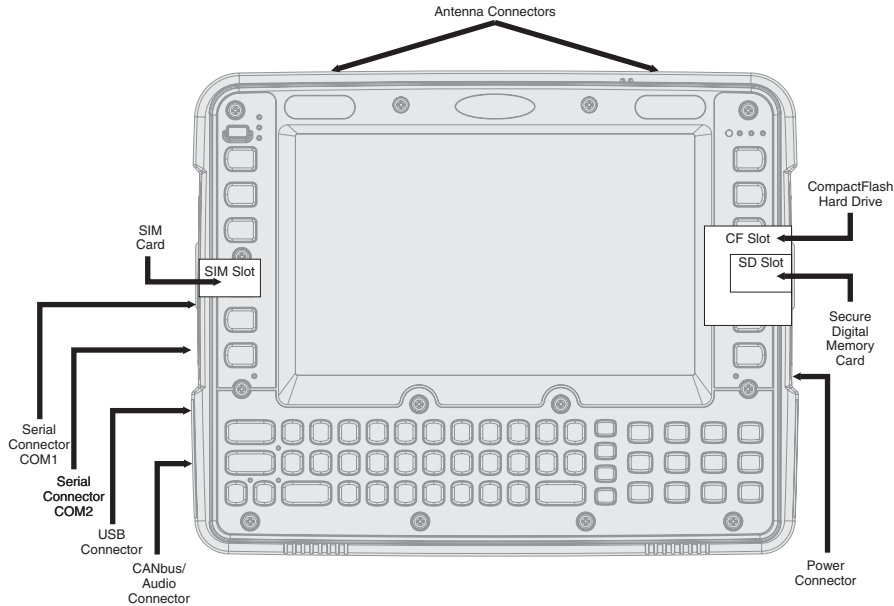

802.11a/b/g/n Wireless Client

The Thor VM1 has an 802.11a/b/g/n network card that supports diversity with two internal or external antennas. Power management for the network card is configured with the [Summit Client Utility](#) (page 6-1).

Central Processing Unit

The CPU is a 1.6 GHz Intel Atom processor. The operating system is Microsoft Windows Embedded Standard 2009. The OS image is stored on an internal CompactFlash memory card and is loaded into DRAM for execution.

Input/Output Components

The Thor VM1 supports the following I/O components of the core logic:

- Two 9-pin RS-232 serial ports, COM1 and COM2.
- One slot for SD memory card.
- CompactFlash (CF) memory card drive.
- Integrated keyboard.
- Ports available via adapter cables: USB host port, CANbus, Audio. USB client port is not supported with Windows Embedded Standard 2009.

System Memory

Main system memory is 2 GB SDRAM.

Video Subsystem

The Thor VM1 video subsystem consists of a color TFT display. The video subsystem complies with the VESA VL bus standard. The resolution of this display is pixels. This resolution complies with the VGA graphics industry standard.

The display supports screen blanking to eliminate driver distraction when the vehicle is in motion.

Audio Interface

Speakers are located on the bottom front of the Thor VM1. A headset adapter cable provides a connection for headset operation. When a headset is plugged into the adapter cable, the main speakers are disabled.

A microphone is located at the upper right of the Thor VM1 display, near the Thor VM1 emblem. When a headset is plugged into the adapter cable, the internal microphone is disabled.

Card Slots

CompactFlash (CF) Slot

The CF ATA slot is not hot swappable. The Thor VM1 must be powered down to insert or remove an ATA card. Since the operating system is stored on the CF ATA card, the Thor VM1 cannot operate without the ATA card.

Secure Digital (SD) Slot

The SD slot accepts an SD memory card. The SD card is hot swappable.

Bluetooth EZPair

The Thor VM1 contains Bluetooth version 2.0 with Enhanced Data Rate (EDR) up to 3.0 Mbit/s over the air. Bluetooth device connection (or pairing) can occur at distances up to 32.8 ft (10 meters) Line of Sight. The wireless client retains wireless connectivity while Bluetooth is active.

The user cannot select PIN authentication or encryption on connections from the Thor VM1. However, the Thor VM1 supports authentication requests from pairing devices. If a pairing device requests authentication or encryption, the Thor VM1 displays a prompt for the PIN or passcode. Maximum encryption is 128 bit. Encryption is based on the length of the user's passcode.

Bluetooth simultaneously supports one printer as a slave Bluetooth device and one scanner, either as a slave or as a master Bluetooth device.

- The LED on the Bluetooth scanner illuminates during a scanning operation.
- Bar code data captured by the Bluetooth scanner can be manipulated by the settings in the optional Freefloat Link*One application.
- Multiple beeps may be heard during a bar code scan using a mobile Bluetooth scanner; beeps from the mobile Bluetooth scanner as the bar code data is accepted/rejected, and other beeps from the Thor VM1 during final bar code data manipulation.

WWAN

WWAN (Wireless Wide Area Networking) is available on the Thor VM1. A slot is provided for a SIM card.

GPS

GPS (Global Positioning System) is available on the Thor VM1.

Power

Vehicle DC Power Supply

Vehicle power input for the Thor VM1 dock is 10V to 60V DC and is accepted without the need to perform any manual operation within the Thor VM1 dock, see [12-48 VDC Vehicles \(10-60 VDC Direct Connection\)](#) (page 4-29). The dock provides a conditioned power output for the Thor VM1. By using a specified DC/DC power supply, input voltage of 50-150V DC can be accepted, see [60-144 VDC Vehicles \(50-150 VDC Power Supply, Screws on Top of Lid\)](#) (page 4-38) or [60-144 VDC Vehicles \(50-150 VDC Power Supply, Screws on Top of Lid\)](#) (page 4-38).

Power input is fused for protection and the fuse is externally accessible, see [Fuse](#) (page 3-4).

External AC Power Supply

If DC power is not available – for example, in an office environment – an optional external Universal Input Power Supply can be used to convert AC wall power to an appropriate DC level. AC to DC power input for the Thor VM1 is delivered to the Quick Mount Smart Dock via an optional external power supply and adapter cable. See [External AC/DC Power Supply](#)

(page 4-47).

Uninterruptible Power Supply

The Thor VM1 contains an internal UPS battery. The user can [Replace UPS Battery](#) (page 4-60).

The UPS battery is automatically charged when the Thor VM1 is placed in a powered dock, provided the safe charging temperature conditions below are met.

When external power is removed, the UPS automatically powers the Thor VM1 with no user intervention. When running on UPS power, the power management timeouts may be different than when vehicle power is applied.

The UPS allows the Thor VM1 to continue operation when not mounted in a dock or when the vehicle battery is being swapped. When fully charged the UPS battery is designed to power the Thor VM1 for a minimum of 30 minutes at temperatures of -20°C (-4°F) or greater. For the extended temperature version of the Thor VM1, the UPS provides a minimum of 10 minutes of operation between -20°C (-4°F) and -30°C (-22°F).

If operating on UPS power and the UPS battery becomes critically low, the Thor VM1 performs a controlled shutdown.

If there is no external power available, there must be 10% or greater power in the UPS battery or the Thor VM1 does not power on.

The UPS status LED and the Battery Control Panel can be used to monitor the state of the UPS battery.

Safe Charging Temperature Range

The internal temperature of the Thor VM1 is the trigger for UPS battery charging.

- The UPS battery is not charged when the internal Thor VM1 temperature is below 0°C (32°F). This corresponds to an ambient (room) temperature of approximately -10°C (-14°F).
- The UPS battery is not charged when the internal Thor VM1 temperature is above 45°C (113°F). This corresponds to an ambient (room) temperature of approximately 35°C (95°F).
- If the UPS battery cannot be charged due to a temperature extreme, the [UPS Status LED](#) (page 3-11) is amber. Move the Thor VM1 to a different location to charge the UPS battery.

When the Thor VM1 is operated in an environment where the UPS battery is not able to charge due to temperature extremes, the Thor VM1 should be removed to a location within the safe charging temperature range during off hours. A discharged UPS battery cannot protect against data loss in the event vehicle power is interrupted.

Charging Timeout

- A fully discharged UPS battery normally recharges in less than 4 hours when the Thor VM1 is in a powered dock and within the safe charging temperature range.
- If the UPS battery is not charged before an 8 hour (or 4 hours for some earlier software revisions) timeout period expires, the [UPS Status LED](#) (page 3-11) is amber.
- The charge timeout is reset if charging resumes upon application of external power.
- The charge timeout is reset if charging resumes when the Thor VM1 enters the permissible temperature range for charging.

Charging and Power Management

- Charging of the UPS battery continues when the Thor VM1 is in power management (display off, suspend or hibernate modes).

Backup Battery

The Thor VM1 has a permanent Lithium battery installed to maintain time, date and CMOS setup information for a minimum of 90 days. The lithium battery is not user serviceable and should last five years with normal use before it requires replacement.

Note: The backup battery should only be changed by authorized service personnel.

Fuse

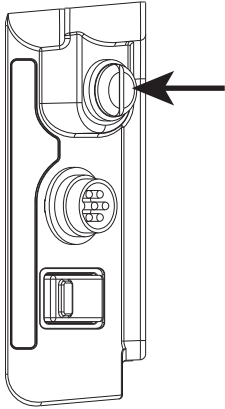

The Thor VM1 uses an 8A time delay (slow blow), fuse that is externally accessible and user replaceable. The fuse is located on the back of the Quick Mount Smart Dock. The fuse is accessed by unscrewing the cap as indicated.

Should it need replacement, replace with same size, rating and type of fuse:

- **Littelfuse 0215008.MXP**
- **Cooper Bussmann BK1/S506-8-R**
- **Bel Fuse 5HT 8-R**

or equivalent.

Fuse has voltage on it even when power is off. Always disconnect input power before changing the fuse.

Power Management Modes

The Thor VM1 has four power modes: Full On, Standby, Hibernate and Off.

Full On Mode

When the Thor VM1 is attached to either vehicle power or an external power supply or is operating from the UPS battery and the power button is pressed, the Thor VM1 is in the On mode. In this mode, the keypad, touch screen and any attached peripherals such as a scanner function normally. The display remains on until the display, standby or hibernate timer (if enabled) expires.

When in Full On mode, the status LED is solid green.

If the Thor VM1 is Full On, a press of the power button can be configured to put the unit in Standby. See the [Advanced](#) (page 5-20) tab of the Power control panel.

StandbyMode

When the standby timer expires without a primary event occurring, the Thor VM1 transitions to Standby mode. Pressing the Power button exits Standby mode and transitions the Thor VM1 to Full On.

When in Standby mode, the status LED:

- blinks green very slowly if external power is attached.
- is off if external power is not attached.

System Standby Wakeup Events

The following event transitions the Thor VM1 from Standby to Full On Mode:

- Pressing and releasing the Power button

Hibernate Mode

When the Thor VM1 enters hibernate mode, all LEDs are off. Pressing the Power button returns the Thor VM1 to Full On.

When in Hibernate Mode, the status LED:

- blinks green very slowly if external power is attached.
- is off if external power is not attached.

System Hibernate Wakeup Events

The following event transitions the Thor VM1 from Hibernate to Full On Mode:

- Pressing and releasing the Power button.

Off Mode

By default, the Thor VM1 turns off if the user presses the power button when the Thor VM1 is On. This behavior can be configured on the [Advanced](#) (page 5-20) tab of the Power control panel.

The Thor VM1 is also off when it is not connected to a power source and the UPS battery is depleted. However, an internal Real Time Clock (RTC) powered by an internal battery maintains the date and time while the Thor VM1 is off.

Power Controls

Power Switch

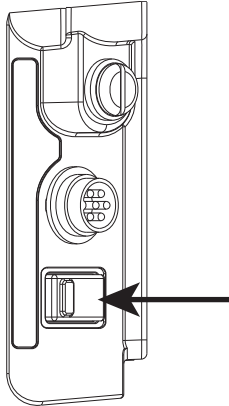

After all cables are connected, the Thor VM1 can be powered on.

There is a power switch located on the back of the Quick Mount Smart Dock. The power switch is a rocker switch.

The power switch has a raised bump to identify the switch position even when it is hidden from view. When the side of the switch with the raised bump is pressed, the power switch is On. If the dock is connected to external power, the dock delivers power to the Thor VM1.

Generally, once the dock is powered On, there is no need to power it off. The dock power can remain On even when the Thor VM1 is not attached.

Power Button

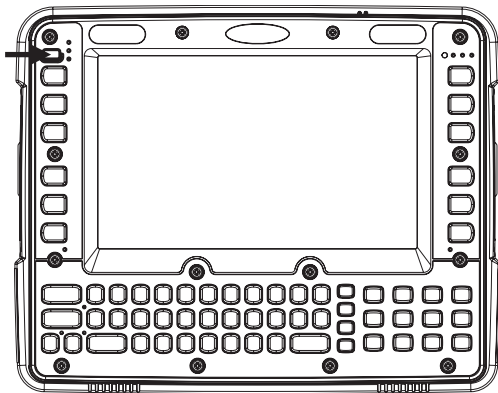

The power button is located at the top left of the Thor VM1.

If the Thor VM1 is Off, pressing the power button starts the power up sequence.

Note: This assumes that the Thor VM1 is docked in a powered Quick Mount Smart Dock or that the internal UPS battery has a sufficient charge to power the Thor VM1. If no external power is available and the UPS battery does not have a charge, pressing the power button causes no action.

If the Thor VM1 is On, pressing the power button performs the option selected in the Advanced tab of the Power control panel:

- Ignore power button press
- Prompt the user to select action
- Shut down (default, an orderly shutdown is performed)
- Standby
- Hibernate

Auto On Behavior

Select the desired Ignition Control / Auto On behavior.

The Thor VM1 Auto On options can be configured using the [AutoOn](#) (page 5-5) control panel. Please refer to that section for more details on the options below.

For information on the Ignition input signal see [Vehicle 10-60VDC Direct Power Connection](#) (page 4-29) and [Auto-On Control Wiring Diagram](#) (page 4-32).

Standard

The Thor VM1 is turned on and off manually by the user using the power button on the front of the device.

Ignition Control

The Thor VM1 is turned on automatically when a signal is received via the Ignition Input wire, which is part of the DC Power Cable.

Auto-On

The Thor VM1 automatically powers up when power is provided.

External Connectors

Power the Thor VM1 off before attaching a cable to any port (serial, USB, Audio/CAN, etc.).

The external I/O connectors for the Thor VM1 are located on the right side of the Quick Mount Smart Dock (when viewed from the back).

The [Power Supply Connector](#) (page 3-7) is on the left side of the dock (when viewed from the back).

Antenna connectors are located on the top rear of the Thor VM1.

Serial Connector (COM1 and COM2)

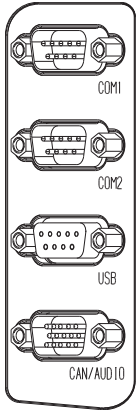

The COM1 and COM2 connectors are D-9 male connectors located on the back of the Quick Mount Smart Dock.

Power the Thor VM1 off before attaching a cable to any port (serial, USB, Audio/CAN, etc.).

The serial connectors are industry-standard RS-232, PC/AT standard 9-pin "D" male connector. See [COM1 and COM2 Connector](#) (page 8-4) for connector pinout detail.

Pin 9 is configured to provide +5V for an external bar code scanner.

See [Connect Serial Device](#) (page 4-48) for more information.

If a COM port is not being used for a scanner, it can be used for [Screen Blanking](#) (page 4-44) when the vehicle is in motion.

Screen Blanking

The screen blanking signal can be provided either by a Honeywell Screen Blanking Box or a user supplied switch or relay. See [Screen Blanking](#) (page 4-44) for information on connecting screen blanking accessories.

USB Connector

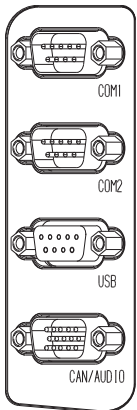

The USB connector is a D-9 female connector located on the back of the Quick Mount Smart Dock. See [USB Connector](#) (page 10-5) for connector pinout detail.

Power the Thor VM1 off before attaching a cable to any port (serial, USB, Audio/CAN, etc.).

The USB client port is not supported with Windows Embedded Standard 2009 operating systems.

See [Connect USB Host](#) (page 4-33) for more information.

CANbus / Audio Connector

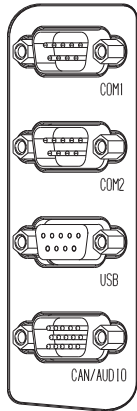

The CANbus/Audio connector is a D-15 male connector located on the back of the Quick Mount Smart Dock.

The connector supports a headset adapter cable or a CANbus cable. The Thor VM1 does not support connecting audio and CANbus simultaneously.

See [CANbus / Audio Connector](#) (page 8-6) for connector pinout detail.

A headset cable attaches to the CANbus / Audio connector and provides a quick connect connection for a headset. See [Connect Headset Cable](#) (page 4-49) for more information.

The CANbus Y cable has a 9 pin F SAE J1939 (Deutsch) and 9 pin M SAE J1939 (Deutsch) connector. See [Connect CANbus Cable](#) (page 4-50) for more information.

The CANbus interface is a virtual COM port. This port can be accessed using standard Windows API calls.

Power Supply Connector

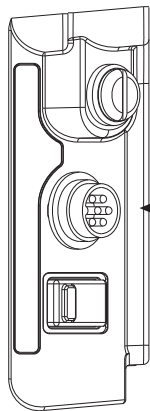

Power is supplied to the Thor VM1 through the power connector. Additionally this assembly provides a connection point for the vehicle's chassis ground to be connected internally to the conductive chassis of the computer.

The Thor VM1 internal power supply can accept DC input voltages in the range of 10 to 60 Volts DC.

See [Power Supply Connector](#) (page 8-4) for connector pinout detail. See [Connect Power](#) (page 4-28) for more information on connecting power to the Thor VM1.

Antenna Connections

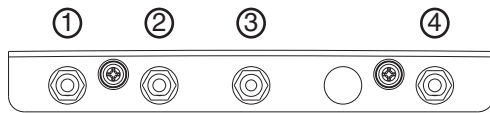

The Thor VM1 is equipped with an 802.11 radio and can be ordered with internal antennas or external remote mount antennas. When the Thor VM1 is ordered with internal antennas, the external antenna connectors are not used. GPS and WWAN are optional on the Thor VM1 and require external remote mount antennas.

1. WI-FI (MAIN) (Red label) 802.11 Main External Antenna Connector
2. WI-FI (AUX) (Yellow label) 802.11 Auxiliary External Antenna Connector
3. GPS (Green label) GPS Antenna Connector
4. MOBILE NET (Blue label) WWAN Antenna Connector

External Antenna Connector

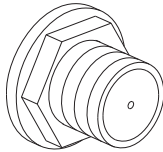

When the Thor VM1 is ordered with the internal antenna option, the 802.11 antenna connectors on the back are not connected to the 802.11 radio. Instead the internal antenna connector is connected to the 802.11 radio.

Remove the rubber cap, if present, from the antenna connector before connecting an external antenna.

Internal 802.11 Antenna

If the internal 802.11 antenna option is ordered, antennas are mounted inside the Thor VM1. The internal antennas are not user accessible.

Vehicle Remote Antenna

The external antennas can be remotely mounted on the vehicle. See [Install Remote Antenna](#) (page 4-51) for instructions. External antenna kits are available for the 802.11 Wi-Fi radio, GPS and WWAN.

Keyboard Options

The 2nd, ALT, CTRL and Shift keys (when present) are sticky keys. The [Keyboard LEDs](#) (page 3-13) identify the active sticky modifier mode state of the keyboard. The Thor VM1 has an integrated keypad with five programmable keys and an available external keyboard.

64-Key QWERTY Keyboard



The Thor VM1 has a QWERTY keyboard, available with a standard overlay, an IBM 3270 overlay or an IBM 5250 overlay.

- Because the keyboard only has 64 keys, all functions are not visible (or printed on the keyboard). Therefore the Thor VM1 keyboard supports what is called hidden keys -- keys that are accessible but not visible on the keyboard.
- The keyboard does not have a NumLock indicator or key. NumLock is always On.

The Thor VM1 keyboard keys are backlit.

- By default, the keyboard backlight follows the display backlight. When the display backlight is on, the keyboard backlight is on.
- If the display backlight brightness is increased (or decreased) the keyboard backlight brightness is increased (or decreased).
- The keyboard backlight and the display share the same timer, which is configured in the [Power Options](#) (page 5-18) control panel.

IBM 3270 Overlay

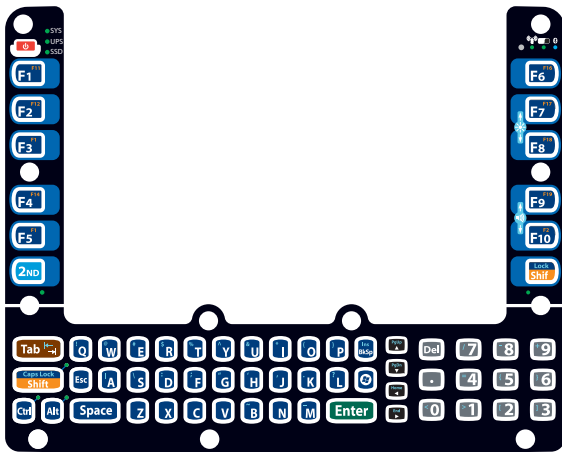

IBM 5250 Overlay



Keypad LEDs

See [Keyboard LEDs](#) (page 3-13) for details.

USB Keyboard / Mouse

A standard USB keyboard or mouse can be attached to the Thor VM1 using the appropriate adapter cable.

The Y cable attaches to the Thor VM1 and provides a USB connector. Please refer to documentation provided with the USB keyboard or mouse for more information on their operation.

LED Functions

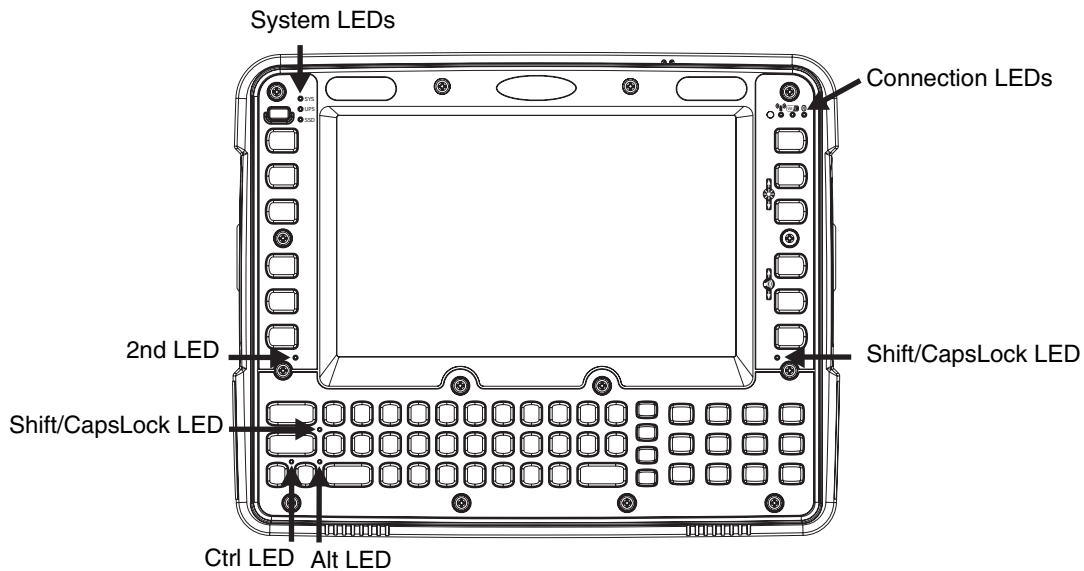

System LEDs

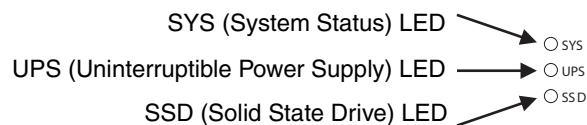

SYS (System Status) LED

LED Behavior	System State
Solid Green	<ul style="list-style-type: none">• On• On but Display Off
Green blinking very slowly External power present (1/2 sec. on, 4 1/2 sec. off)	<ul style="list-style-type: none">• Standby
Off External power present	<ul style="list-style-type: none">• Hibernate• Off
Off External power not present	<ul style="list-style-type: none">• Hibernate• Standby• Off
Green blinking slowly External power present (1/2 sec. on, 1 1/2 sec. off)	CPU temperature less than -20°C, Heater warming CPU for 30 sec.
Green blinking slowly External power not present (1/2 sec. on, 1 1/2 sec. off)	CPU temperature less than -20°C, Need to move unit to warmer environment

UPS Status LED

The behavior of the UPS LED depends if external power is connected or not.

External Power Present

LED Behavior	Status
Off	<ul style="list-style-type: none">• No UPS charging• UPS charged
Solid Green	UPS charging
Solid Amber	<ul style="list-style-type: none">• Any charging fault• Out of Safe Charging Temperature Range (page 3-3) Charging only occurs between approximately -10°C and 35°C ambient temperature.• No UPS present• Charging Timeout (page 3-3) Not fully charged after 4 or 8 hours depending on software revision.

External Power Not Present

LED Behavior	Status
Off	<ul style="list-style-type: none">• Unit off• UPS not present
Solid Amber	UPS supplying power and discharging
Solid Red	Approximately 2 minutes runtime until shutdown

SSD (Solid State Drive) LED

LED Behavior	Status
Flashing Green	SSD read or write activity
Off	No SSD read or write activity

Connection LEDs

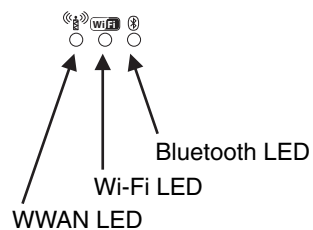

WWAN LED

LED Behavior	Status
Solid Green	Indicates a WWAN connection to a network
Off	Indicates no WWAN connection

Wi-Fi LED

LED Behavior	Status
Solid Green	Indicates a connection with an IP address to an Access Point
Off	Indicates no connection to an Access Point

Bluetooth LED

LED Behavior	Status
Blue Blinking Slowly	Bluetooth is paired but not connected to a device
Blue Blinking Medium	Bluetooth is paired and connected to a device
Blue Blinking Fast	Bluetooth is discovering Bluetooth devices
Off	Bluetooth hardware has been turned off

The Bluetooth LED blinks once every 6 seconds when the Bluetooth client is paired but not connected. It blinks once for a very short time every 2 seconds when paired and connected. It blinks every second when in discovery. The LED is off when the Bluetooth client is off.

Keyboard LEDs

The keyboard LEDs are located near the specified key.

2nd LED

LED Behavior	Status
Solid Green	<ul style="list-style-type: none">Indicates the 2nd modifier key is active. 2nd mode is invoked for the next keypress only.Pressing the 2nd key a second time exits this modifier mode and turns off the LED.
Off	2nd mode is not invoked.

Shift LEDs

There is one LED next to each **Shift** key. Both LEDs indicate the status of Shift mode and Caps Lock mode.

LED Behavior	Status
Blinking Green	<ul style="list-style-type: none">Indicates the keypad is in Shift mode. Shift mode is invoked for one keypress.Pressing the Shift key places the system in Shift mode.To exit Shift mode, press the Shift key again.
Solid Green	<ul style="list-style-type: none">When solid Green, indicates the keypad is in Caps Lock mode. Caps Lock mode is invoked until canceled.Pressing the 2nd key followed by the Shift key places the system in Caps Lock mode.To exit Caps Lock mode, press 2nd + Shift again.
Off	Neither Shift or Caps Lock mode is invoked.

Ctrl LED

The **Ctrl** key is not present on the 12-key keypad.

LED Behavior	Status
Solid Green	<ul style="list-style-type: none">Indicates the Ctrl modifier key is active. Ctrl mode is invoked for the next keypress only.Pressing the Ctrl key a second time exits this modifier mode and turns off the LED.
Off	Ctrl mode is not invoked.

Alt LED

The **Alt** key is not present on the 12-key keypad.

LED Behavior	Status
Solid Green	<ul style="list-style-type: none">Indicates the Alt modifier key is active. Alt mode is invoked for the next keypress only.Pressing the Alt key a second time exits this modifier mode and turns off the LED.
Off	Alt mode is not invoked.

Display

The display is a thin-film transistor display capable of supporting WSVGA graphics modes. Display size is 800 x 480 pixels. The display covering is designed to resist stains. The touch screen allows signature capture and touch input. The display supports screen blanking to eliminate driver distraction when the vehicle is in motion.

Touch Screen

The touch screen is a Resistive Panel with a scratch resistant finish that can detect touches by a stylus, and translate them into computer commands. In effect, it simulates a computer mouse. Only Delrin or plastic styluses should be used. A right mouse click is simulated by touching and holding the screen for the appropriate time interval.

When a dialog box is too large for the display, tap and drag the dialog box up or down or from side to side to view the remainder of the dialog box.

Always use the point of the stylus for tapping or making strokes on the display. Never use an actual pen, pencil, sharp or abrasive object to write on the touch screen.

An extra or replacement stylus may be ordered.

A replaceable touch screen protective film is available when the Thor VM1 is used in an abrasive environment. Contact [Technical Assistance](#) (page 9-1) for availability.

Touch Screen Defroster

Extended temperature versions of the Thor VM1 contain a touch screen defroster. The touch screen defroster can be disabled when not needed via the [Screen Control](#) (page 5-22) panel. The defroster trip point is configurable. The defroster is always disabled when the device is operating from UPS battery power.

Screen Blanking

Screen blanking (blackout) can be enabled when the vehicle is in motion. See [Screen Blanking](#) (page 4-44) for hardware setup and [Screen Control](#) (page 5-22) for software setup to enable screen blanking. Once screen blanking is enabled, the display is blanked out any time when the cable sends the signal the vehicle is in motion. If the cable is removed, screen blanking is disabled and the display remains on.

Display Backlight Control

The display brightness on a Thor VM1 equipped with an outdoor display can be configured to automatically adjust depending on the ambient light level via [Screen Control](#) (page 5-22).

Note: When automatic brightness control is enabled, the manual display brightness controls described below have no effect.

The display brightness can be adjusted manually, via the keypad:

- Use the **2nd + F7** keypress to increase backlight brightness and the **2nd + F8** keypress to decrease backlight brightness.

Vehicle Mounting and Accessory Installation

Introduction

The Thor VM1 is designed to be mounted to a Quick Mount Smart Dock in a vehicle with either a RAM mount or U Bracket system. A power cable is provided with the Thor VM1 dock. Optional communication cables are available.

Vehicle mounting brackets are specifically designed for vehicle mount applications. The vehicle mounted assembly restrains the Thor VM1 and isolates it from shock and vibration. A RAM metal table stand is available to secure the Thor VM1 and dock when in an office environment, for example.

The vehicle mount holds the Quick Mount Smart Dock and the Thor VM1 attaches to the dock. The dock remains attached to the vehicle, however, the Thor VM1 has a quick release located on the lower rear side that allows the Thor VM1 to easily be removed from the dock. The Thor VM1 can be operated for a minimum of 30 minutes from an internal UPS battery when not attached to a dock. The Thor VM1 can be transferred from one dock equipped vehicle to another for easy portability. The dock provides accessory attachment and conditioned power for the Thor VM1.

Overhead, dash and roof support pillar mounting is via a RAM Mount or U-bracket accessory which includes all the hardware required for vehicle mounting.

Never put the Thor VM1 into the vehicle mounted assembly until the assembly is securely fastened to the vehicle.

Prepare for Vehicle Mounting

The Thor VM1 should be secured to an area in the vehicle where it:

- Does not obstruct the driver's vision or safe vehicle operation.
- Will be protected from rain or inclement weather.
- Will be protected from extremely high concentrations of dust or wind-blown debris.
- Can be easily accessed by a user seated in the driver's seat while the vehicle is not in operation.

Quick Start

The following list outlines, in a general way, the process to follow when mounting the Thor VM1 in a vehicle. Refer to the following sections in this document for more details.

1. [Install RAM Mount](#) (page 4-18) or [Install U Bracket Mount](#) (page 4-24) to the vehicle.
2. [Place Thor VM1 in the Dock](#) (page 4-16).
3. Adjust the Thor VM1 to the best viewing angle.
4. [Install Remote Antenna](#) (page 4-51) if necessary.
5. [Connect Cables](#) (page 4-27) for any peripherals.
6. Connect vehicle power:
 - [12-48 VDC Vehicles \(10-60 VDC Direct Connection\)](#) (page 4-29)
 - [60-144 VDC Vehicles \(50-150 VDC Power Supply, Screws on Top of Lid\)](#) (page 4-38)
 - [60-144 VDC Vehicles \(50-150 VDC Power Supply, Screws on Side of Lid\)](#) (page 4-34).
 - [Thor VX8 / Thor VX9 Adapter Cable](#) (page 4-43)
 - [VX6 / VX7 Adapter Cable](#) (page 4-42)
7. Secure all cables in [Strain Relief Cable Clamps](#) (page 4-27).

The Thor VM1 is ready for use.

Maintenance - Vehicle Mounted Devices

Check the vehicle mounting hardware frequently and re-tighten if necessary.

If the vehicle mounting hardware and connections become broken, loose or cracked, the assembly must be taken out of service and replaced. Contact [Technical Assistance](#) (page 9-1) for help.

Cleaning

Do not use paper towels or harsh-chemical-based cleaning fluids since they may result in damage to the Thor VM1 surfaces, cables, connectors and mounting hardware.

Use a clean soft cloth to wipe any dirt, moisture or grease from the Thor VM1, connectors, cables or the vehicle mounting hardware. Do not use any liquid to clean the Thor VM1, or connectors. Spray or dampen the cleaning cloth with the cleaning liquid. If possible, clean only those areas which are soiled. Lint/particulates can be removed with clean, filtered canned air.

Place Thor VM1 in the Dock

Back of Thor VM1

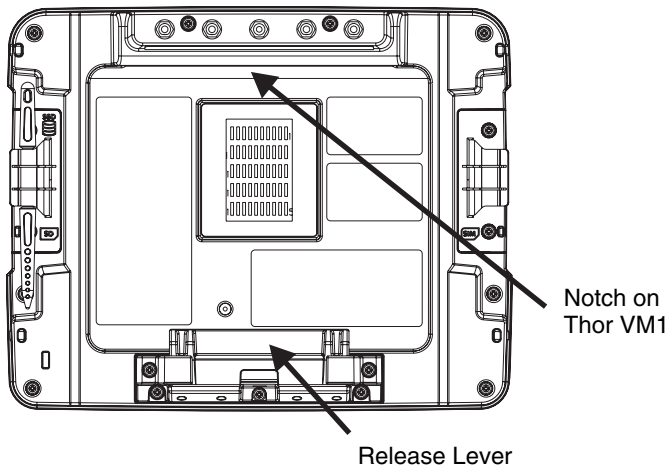

Front of Quick Mount Smart Dock

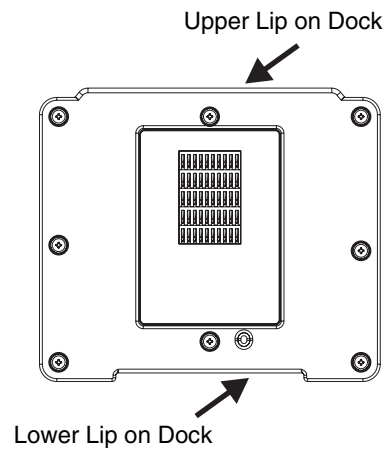

1. Locate the notch on the upper rear of the Thor VM1.
2. Slide this notch over the top lip of the dock. Slide the Thor VM1 from side to side on the dock to make sure it fully engages on the lip of the dock. If the Thor VM1 cannot be slid side to side, the lip is engaged.
3. Pull the quick release lever on the Thor VM1 down and push the Thor VM1 against the dock.
4. Release the quick release lever. The quick release lever catches the lower lip on the dock and secures the Thor VM1 to the dock.
5. If necessary, adjust the viewing angle of the Thor VM1.

When the Thor VM1 is placed in the dock, the following may happen:

- If the Thor VM1 is off and power is connected to the dock, the Thor VM1 may boot when placed in the dock. See [AutoOn](#) (page 5-5).
- If the Thor VM1 is on and power is connected to the dock, the Thor VM1 power management timers may change when the Thor VM1 is placed in the dock. See [Power Schemes](#) (page 5-18).

When the Thor VM1 is removed from the dock, the following may happen:

- If the Thor VM1 is on and power is connected to the dock, the Thor VM1 power management timers may change when the Thor VM1 is placed in the dock. See [Power Schemes](#) (page 5-18).

Dock I/O Pin Cover.

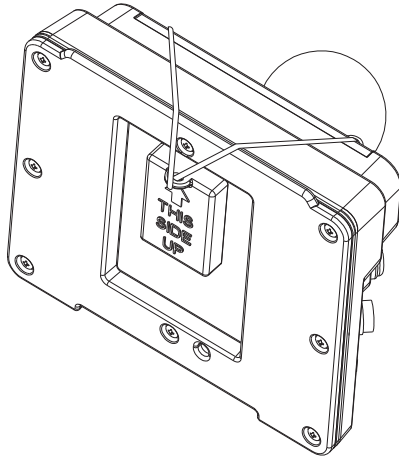

The dock contains a tethered I/O Pin Cover to protect the I/O pins on the dock when a Thor VM1 is not mounted in the dock.

- When the Thor VM1 is not installed in the dock, use the I/O Pin Cover to protect the pins on the dock as shown.
- When a Thor VM1 is installed in the dock, the I/O Pin Cover can be placed out of the way behind the dock.

Padlock

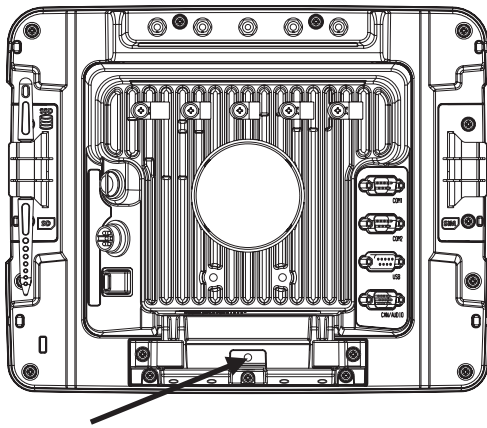

It may be desirable to secure the Thor VM1 in the dock so it cannot be removed from the dock. The quick release handle on the Thor VM1 is notched to allow a user supplied standard padlock to be placed through a hole in the bracket on the back of the Thor VM1 in the location shown below. Once the padlock is installed, the release handle cannot be moved so the Thor VM1 cannot be removed from the dock. The padlock shackle must be smaller than 3/16" (4.76mm).

A cable tie wrap can be used instead of a padlock if desired.

Laptop Security Cable

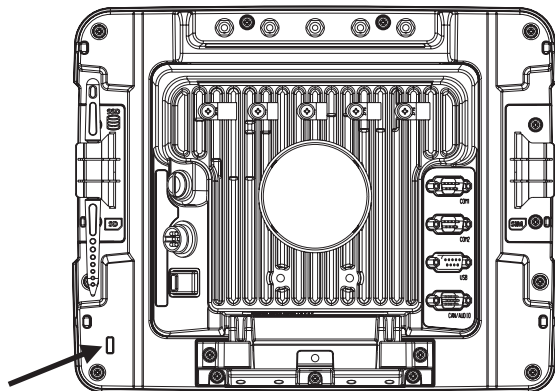

The Thor VM1 can be secured with a standard laptop security cable using the slot on the back of the Thor VM1.

Install RAM Mount



CAUTION - This device is intended to transmit RF energy. For protection against RF exposure to humans and in accordance with FCC rules and Industry Canada rules, this transmitter should be installed such that a minimum separation distance of at least 20 cm (7.8 in.) is maintained between the antenna and the general population. This device is not to be co-located with other transmitters.

Before installation begins, verify you have the applicable vehicle mounting bracket assembly components necessary, as shown in the following figures.

Components - RAM Mounting Kits

In addition to the kits below, individual RAM mounting components are also available.

Each mounting kit contains:

RAM Ball (Size D) for back of Thor VM1 Quick Mount Smart Dock with hardware (screws and washers) to attach RAM ball to dock

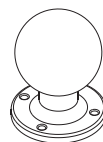

RAM Arm (Size D), length varies by kit selected

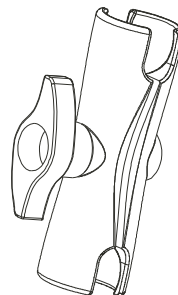

One of three mounting options:

- RAM Ball mount (Size D, may include 3 cone washers), or

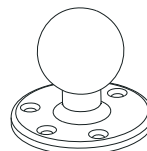

- RAM Clamp mount (Size D), or

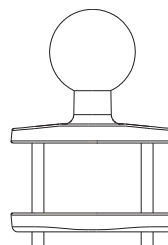

- RAM Plate mount with RAM Ball (Size D) with Hardware (cone washers and nuts) to attach Ball to Plate

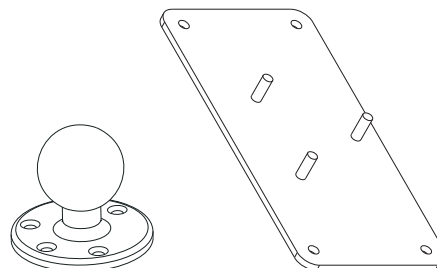

Procedure - RAM Mount Assembly

Equipment Needed: Sockets, screwdriver and a Torque wrench capable of measuring to 50 inch pounds (5.64±.56 N/m).

Note: Torquing tool is not supplied by Honeywell. Tools needed to attach the RAM Clamp Mount to the vehicle are not supplied by Honeywell.

Torque Measurement

You will need a torquing tool capable of torquing to 20 inch pounds (1.10 N/m). Torque all screws and bolts according to the following table:

For these nuts...	Torque to
10-32 lock nuts	17 - 20 in/lb (0-95 - 1.10 N/m)

Step 1a – Attach RAM Ball to Vehicle

Note: If you are using the RAM clamp mount, please go to [Step 1b – Mount RAM Clamp to Vehicle](#) (page 4-20). If you are using the RAM plate mount, please go to [Step 1c – Attach RAM Plate to Vehicle and Attach RAM Ball](#) (page 4-21).

1. Determine the position for mounting the RAM ball base. Be sure to position the RAM bracket to allow access to the switches and ports on the bottom of the Thor VM1.
2. Attach the RAM ball base to the vehicle mounting surface using three or four 1/4 bolts (not included) or equivalent fasteners. If the mounting kit includes cone washers, use those as illustrated below.

IMPORTANT: Mount to the most rigid surface available.

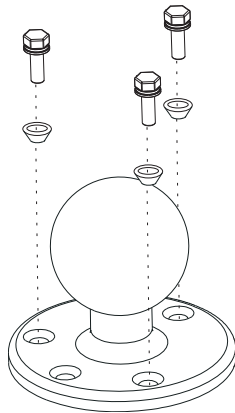

Mounting Dimensions

Note: Drill and tap holes for three 1/4 bolts. Drawing not to scale.

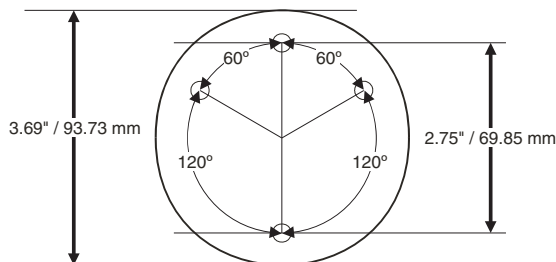

Step 1b – Mount RAM Clamp to Vehicle

Note: If you are using the RAM ball mount, please go to [Step 1a – Attach RAM Ball to Vehicle](#) (page 4-19). If you are using the RAM plate mount, please go to [Step 1c – Attach RAM Plate to Vehicle and Attach RAM Ball](#) (page 4-21).

1. Determine the position for mounting the RAM clamp mount. The clamp mount can be used on a beam (such as on a fork lift truck) up to 2.5" (63.5 mm) wide and approximately 2" (50.8 mm) thick. The clamp may be attached to a thicker beam by substituting longer bolts (not included). Be sure to position the RAM clamp mount to allow access to the switches and ports on the bottom of the Thor VM1.

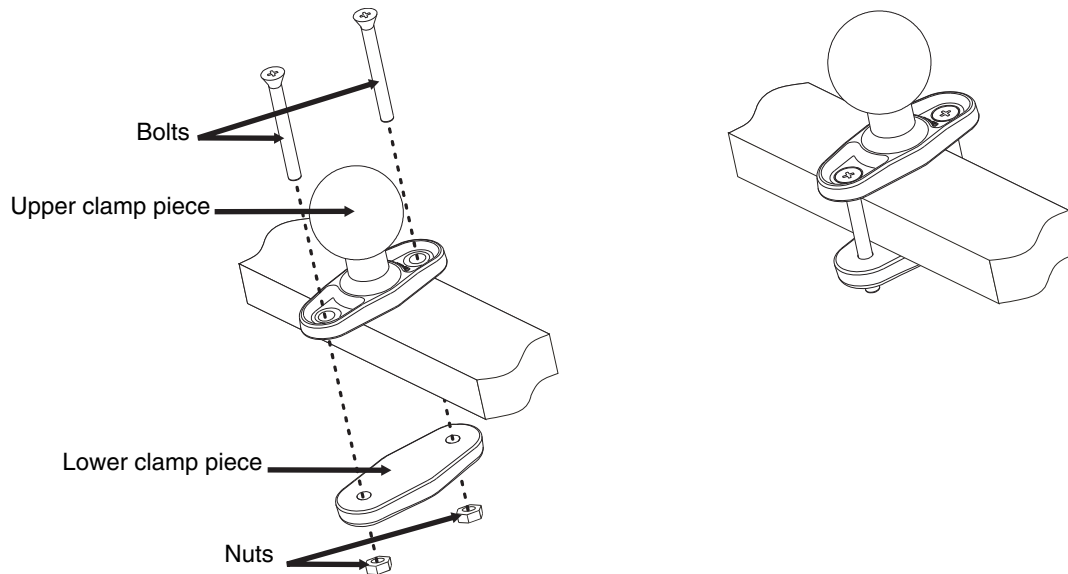

2. Position the upper clamp piece with ball on the beam. Place the bolts through the holes in the upper clamp piece.
3. Position the lower clamp piece below the beam. Align the bolts with the holes in the lower clamp piece.
4. Place the nylon locking nuts on the bolts and tighten the bolts.

Mounting Dimensions

Note: Drawing not to scale.

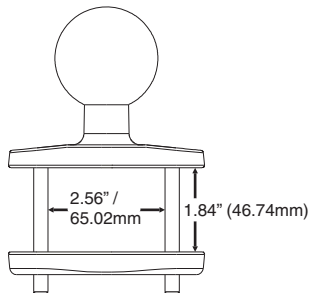

Step 1c – Attach RAM Plate to Vehicle and Attach RAM Ball

Note: If you are using the RAM ball mount, please go to [Step 1a – Attach RAM Ball to Vehicle](#) (page 4-19) If you are using the RAM clamp mount, please go to [Step 1b – Mount RAM Clamp to Vehicle](#) (page 4-20).

1. Determine the position for mounting the RAM ball plate. Be sure to position the RAM plate to allow access to the switches and ports on the bottom of the Thor VM1.
2. Attach the RAM ball plate to the vehicle mounting surface using four 1/4 bolts (not included) or equivalent fasteners.
3. If not already attached, attach the RAM ball to the RAM ball plate using three M6 nuts and washers.

IMPORTANT: Mount to the most rigid surface available.

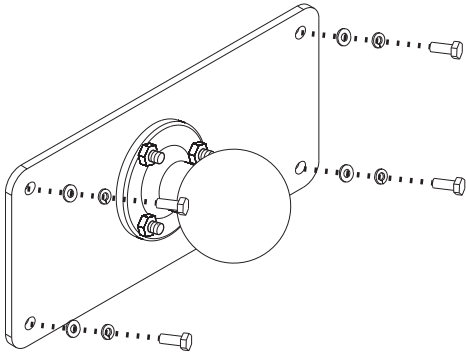

Mounting Dimensions

There are 4 mounting holes in the plate. Use four 1/4 bolts to secure the plate to the vehicle.

Note: Drawing not to scale.

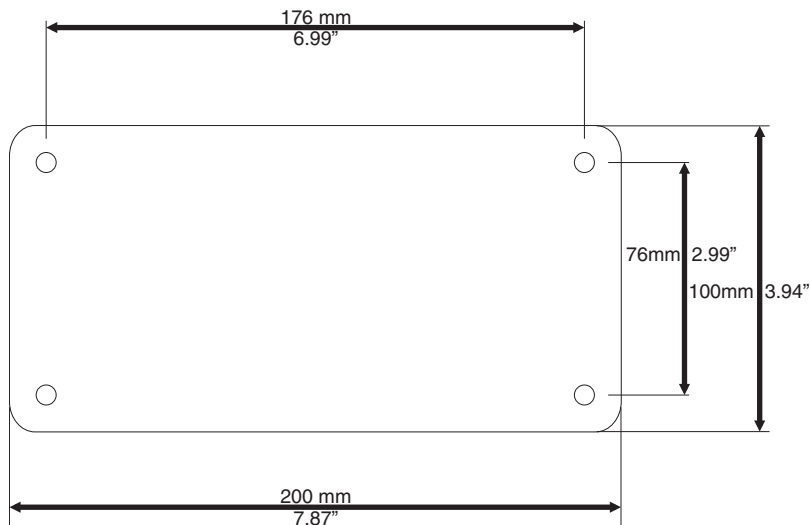

Step 2 – Attach RAM Mount Ball to the Thor VM1 Quick Mount Smart Dock

1. Turn the Thor VM1 off before attaching the RAM mount ball.
2. Place the Thor VM1 face down on a stable surface.
3. Position the RAM ball on the rear of the Thor VM1 dock, aligning the holes on the back of the Thor VM1 dock with the holes on the RAM ball base. Attach with four M5 screws, flat washers and lock washers.

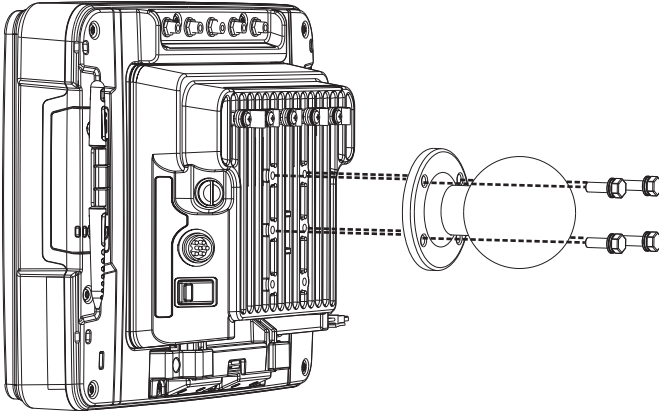

Step 3 – Attach Thor VM1 Assembly to RAM Mount

1. Slip the Size D RAM arm over the ball on the vehicle RAM mount (RAM Ball mount shown).
2. Insert the ball on the dock into the RAM arm and tighten the knob on the RAM arm using the supplied RAM wrench.

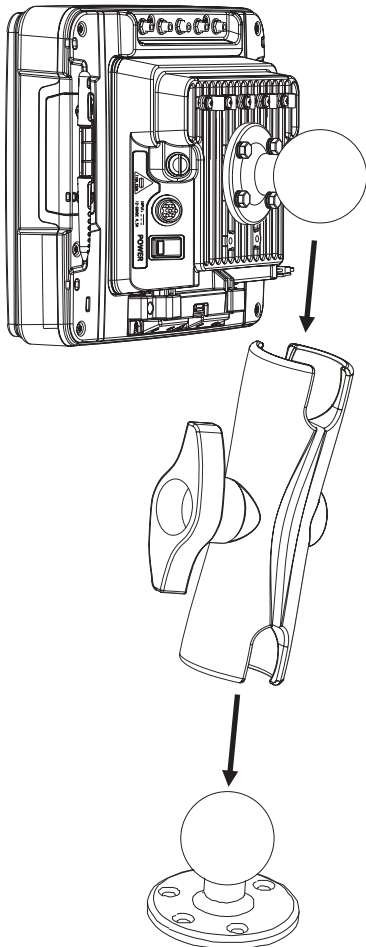

Step 4 – Place the Thor VM1 into the Dock

If the Thor VM1 is not already mounted to the dock, [Place Thor VM1 in the Dock](#) (page 4-16)

Install U Bracket Mount

Before installation begins, verify you have the applicable vehicle mounting bracket assembly components necessary, as shown



CAUTION - This device is intended to transmit RF energy. For protection against RF exposure to humans and in accordance with FCC rules and Industry Canada rules, this transmitter should be installed such that a minimum separation distance of at least 20 cm (7.8 in.) is maintained between the antenna and the general population. This device is not to be co-located with other transmitters.

in the following figures.

Components - U Bracket Mounting Assembly

The U bracket kit is available in two configurations:

- With a U Bracket included for new vehicle installations
- Without a U Bracket for installing the Thor VM1 in place of a previous Honeywell vehicle mounted computer, such as a VX6 or VX7.

U Bracket (only included in kits for new installations)

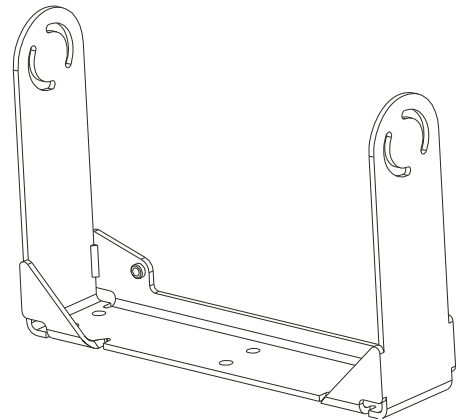

Adapter Bracket (includes screws, flat washers and lock washers to attach Adapter Bracket to Thor VM1 and to attach Adapter Bracket to existing U Bracket (for example, to a vehicle where a VX1, VX2, VX4, VX5, VX6 or VX7 was previously installed)

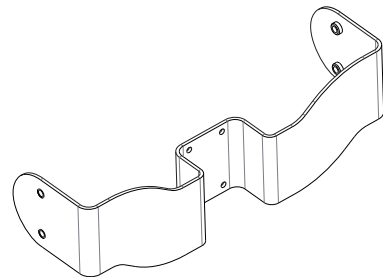

Procedure - U Bracket Assembly

Equipment Needed: Sockets and a Torque wrench capable of measuring to 50 inch pounds (5.64±.56 N/m).

Note: Torquing tool is not supplied by Honeywell.

Torque Measurement

You will need a torquing tool capable of torquing to 35-50 inch pounds (1.10 N/m). Torque all screws and bolts according to the following table:

For these bolts...	Torque to
1/4-20x5/8 Bolts	50 in/lb (5.6 N/m)
M5x16mm Bolts	35 in/lb (4.0 N/m)
1/4 Bolts (user supplied)	50.0±5 in/lb (5.64±.56 N/m)

Mounting Positions

The adapter bracket can be mounted in a high or low position, depending on viewing position, as shown below.

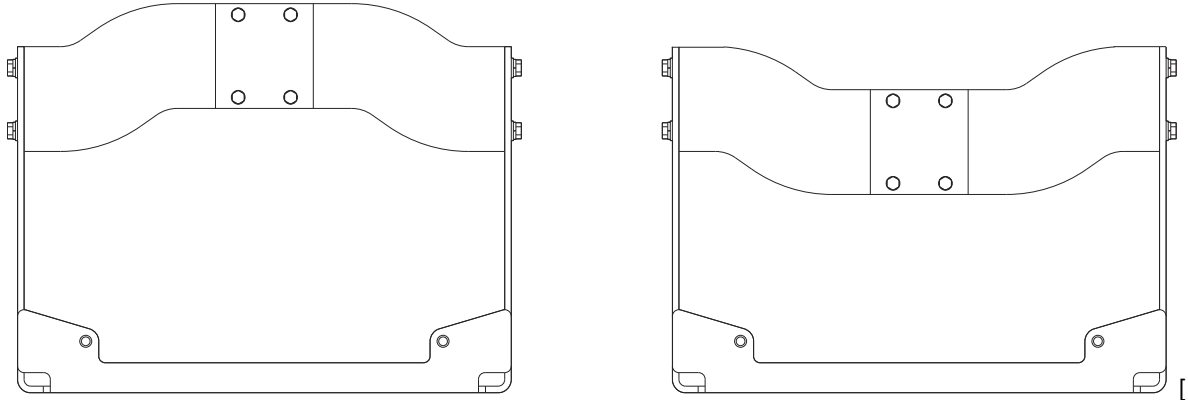

Additionally, the slotted U bracket allows the Thor VM1 to be mounted vertically or tilted forward or backward for best viewing angle.

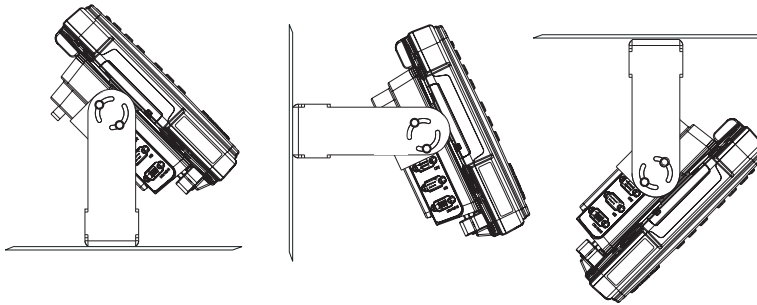

Step 1 - Install U Bracket to Vehicle

1. Position the bracket to allow access to the switches and ports on the bottom of the Thor VM1.
2. Attach the bottom mounting bracket to the vehicle mounting surface using a minimum of four 1/4 bolts (or equivalent) fasteners.

Note: 1/4 bolts and washers not included. It is recommended to use lock washers and flat washers on the fasteners.

IMPORTANT: Mount to the most rigid surface available.

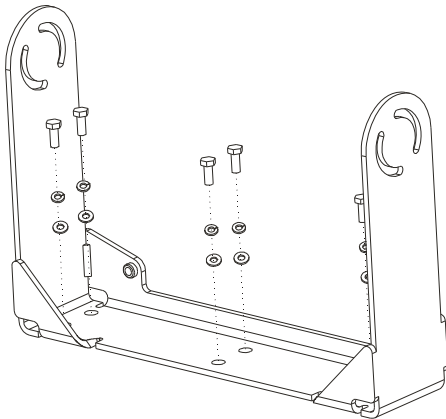

After the bottom bracket has been attached to a rigid surface, you are ready to assemble the Thor VM1 bracket configuration.

Mounting Dimensions

Note: Drawing not to scale.

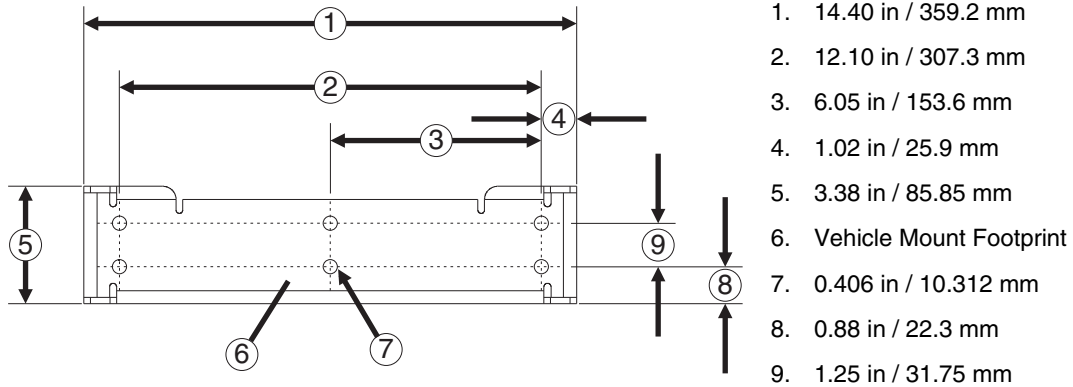

Step 2 - Remove RAM Ball

If the Thor VM1 Quick Mount Smart Dock has a RAM ball attached, the RAM ball must be removed from the dock to use the U Bracket mount.

Remove the RAM ball. The hardware used to attach the RAM ball to the dock is not reused for the U bracket mount.

Step 3 - Attach Adapter Bracket

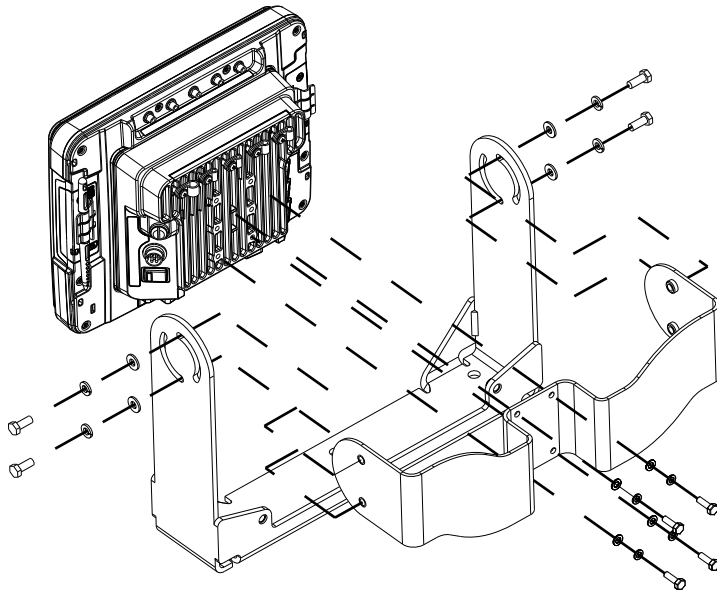

Note: For the steps below, always place the lock washer on the bolt before the flat washer.

1. Attach the Adapter Bracket to the Thor VM1 dock using four each M5x16mm bolt, M5 lock washer and M5 flat washer. Torque to 35 in/lbs (4.0 N/m).
2. Attach the Thor VM1/Adapter Bracket assembly to the U Bracket using 4 each 1/4-20x5/8 bolt, 1/4 lock washer and 1/4 flat washer.
3. If the Thor VM1 is not already mounted to the dock, [Place Thor VM1 in the Dock](#) (page 4-16).
4. Adjust the Thor VM1 to the desired viewing angle.
5. Torque the 14-20 bolts to 50 in/lbs (5.6 N/m).

Connect Cables

There are many cables available for the Thor VM1 including power cables, and data/ communication cablesThor VM1.

Strain Relief Cable Clamps

Equipment Required: Phillips screwdriver (not supplied by Honeywell)

There are five strain relief cable clamps secured to the Thor VM1 Quick Mount Smart Dock.

Use the strain relief clamps to secure audio, power, and I/O cables attached to the Thor VM1 dock.

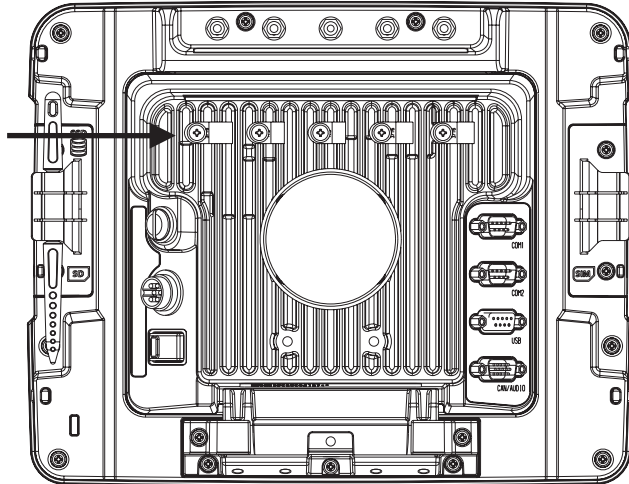

1. Determine the proper strain relief cable clamp. There are three sizes of cable clamps on the Thor VM1 which should be matched to the cable to be secured. For example, the largest clamp (on the left when viewing the back of the Thor VM1) is designed to secure the power cable.
2. Remove the strain relief clamp from the Thor VM1 by turning the screw counterclockwise. Put the screw aside in a safe location.
3. Slide the strain relief clamp over the cable.
4. Using a Phillips screwdriver and the screw that was removed, refasten the clamp holding the cable to the Quick Mount. Do not stretch the cable. Leave enough slack in the cable to allow it to be connected and disconnected easily when needed.
5. Continue in this manner until all cables are secured to the Thor VM1 dock.

Connect Power

Power options include:

- [12-48 VDC Vehicles \(10-60 VDC Direct Connection\)](#) (see page 4-29) - Direct connection to vehicle power.
- [60-144 VDC Vehicles \(50-150 VDC Power Supply, Screws on Side of Lid\)](#) (see page 4-34) - Requires the use of a DC/DC power supply.
- [60-144 VDC Vehicles \(50-150 VDC Power Supply, Screws on Top of Lid\)](#) (see page 4-38) - Requires the use of a DC/DC power supply.
- [VX6 / VX7 Adapter Cable](#) (see page 4-42) - For applications where the Thor VM1 replaces a previously installed VX6 or VX7.
- [Thor VX8 / Thor VX9 Adapter Cable](#) (see page 4-43) - For applications where the Thor VM1 replaces a previously installed Thor VX8 or Thor VX9.
- [Screen Blanking](#) (see page 4-44) - Optional connection to blank the Thor VM1 display while the vehicle is in motion.
- [External AC/DC Power Supply](#) (see page 4-47) - For use when DC power is not available to power the Thor VM1, such as in an office environment.

See [Power Supply Connector](#) (page 8-4) for connector pinout

Power Cable Cautions



CAUTION - When routing the power cable:

- Route power cable away from the outside of the fork truck.
- Choose a mounting location so that the power cable does not extend outside the vehicle and that provides sufficient clearance so that the power cable (especially the dock connector end) is not pressed against part of the vehicle.
- Use the proper [Strain Relief Cable Clamps](#) (page 4-27) to secure cable.
- The power cable is less flexible in low temperature environments. Avoid sharp bends.

Regularly inspect power cable for damage, especially in low temperature environments. Contact [Technical Assistance](#) (page 9-1) for replacement cable options.

Power Cable Routing

Power cable with straight connector

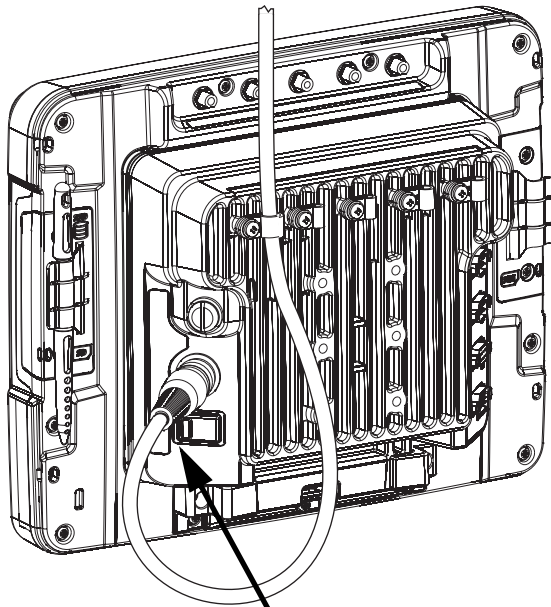

Avoid sharp bends in this area of the power cable

Power cable with right-angle connector

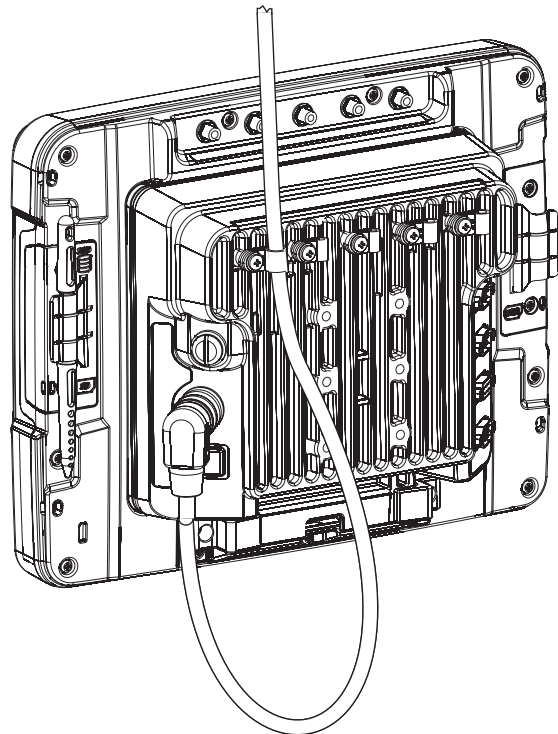

12-48 VDC Vehicles (10-60 VDC Direct Connection)



CAUTION - For installation by trained service personnel only.



Use caution when routing the power cable. See [Power Cable Cautions](#) (page 4-28).



Fuse Requirements

WARNING - For proper and safe installation, the input power cable must be connected to a fused circuit on the vehicle. If the supply connection is made directly to the battery, the fuse should be installed in the positive lead within 5 inches of the battery's positive (+) terminal. The fused circuit requires a maximum time delay (slow blow) fuse with a current rating as noted below.

- For **12VDC** input, use a 10A slow blow fuse that has a DC voltage rating greater than 12VDC.
- For **24VDC** input, use a 6A slow blow fuse that has a DC voltage rating greater than 24VDC.
- For **36VDC** input, use a 4A slow blow fuse that has a DC voltage rating greater than 36VDC.
- For **48VDC** input, use a 3A slow blow fuse that has a DC voltage rating greater than 48VDC.

Note: For North America, a UL Listed fuse is to be used

Power Cable Identification

The DC power cable (included with the dock) is one of the two styles below:

Power cable with **right angle connector** and **6** wires:

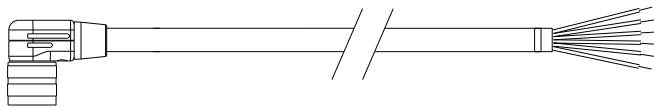

Twist the red and red/white wires together and twist the black and black/white wires together before connecting to vehicle power.

Wire Color	Connection
Red	DC + (10-60 VDC)
Red/White	DC + (10-60 VDC)
Black	DC -
Black/White	DC -
Green	Ground
Blue	Ignition Input (optional)

Power cable with **straight connector** and **4** wires:

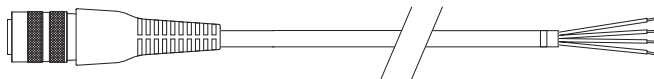

Wire Color	Connection
Red	DC + (10-60 VDC)
Black	DC -
Green	Ground
Blue	Ignition Input (optional)

Note: Correct electrical polarity is required for safe and proper installation. See the figures below for additional wire color-coding specifics.

The Thor VM1 DC input wires (Red, Red/White DC+ and Black, Black/White DC-) and the Blue ignition input wire are galvanically isolated. The Green ground input is used for electrostatic discharge (ESD) protection.

Vehicle 10-60VDC Direct Power Connection

1. The Thor VM1 must not be mounted in the Quick Mount Smart Dock. The power switch on the dock must be turned *Off*. The power cable must be UNPLUGGED from the dock.
2. While observing the [Fuse Requirements](#) (see page 4-29), connect the power cable as close as possible to the actual battery terminals of the vehicle (if using unswitched power).
3. Use proper electrical and mechanical fastening means for terminating the cable. Properly sized "crimp" type electrical terminals are an accepted method of termination. Please select electrical connectors sized for use with 20AWG (0.81mm²) conductors.
4. Refer to the wiring diagrams following this section for wire colors and connections:
 - [Ignition Control Wiring Diagram](#) (page 4-31)

-
- [Auto-On Control Wiring Diagram](#) (page 4-32)
 - [Manual Control Wiring Diagram](#) (page 4-33)
5. Route the power cable the shortest way possible removing any left-over cable. The cable is rated for a maximum temperature of 105°C (221°F). Therefore, when routing this cable it should be protected from physical damage and from surfaces that might exceed this temperature. Cable should be protected from physical damage from moving parts. Do not expose the cable to chemicals or oil that may cause the wiring insulation to deteriorate. Always route the cable so that it does not interfere with safe operation and maintenance of the vehicle.
 6. Provide mechanical support for the cable by securing it to the vehicle structure at approximately one foot intervals, taking care not to over tighten and pinch conductors or penetrate outer cable jacket.
 7. Connect the watertight connector end of the power cable to the Thor VM1 Quick Mount Smart Dock power connector by aligning the connector pins to the power connector; push down on the watertight connector and twist it to fasten securely.
 8. Secure the power cable to the Thor VM1 using the [Strain Relief Cable Clamps](#) (page 4-27).
 9. [Place Thor VM1 in the Dock](#) (page 4-16)
 10. If using the [Screen Blanking](#) (page 4-44) feature, install the screen blanking box or switch.
 11. Press the [Power Switch](#) (page 3-5) on the back of the Thor VM1 dock.
 12. Press the [Power Button](#) (page 3-5) on the front of the Thor VM1 to turn on the Thor VM1.

Once installation is complete, remember to start the Thor VM1 and configure the Auto-On behavior.

See the [AutoOn](#) (page 5-5) control panel.

Ignition Control Wiring Diagram

Ignition wire must be connected and **Ignition Control** must be selected on the [AutoOn](#) (page 5-5) control panel. When switched vehicle power is available the Thor VM1 ignition signal wire can be connected (less than 1mA over input voltage range) to the switched circuit to allow the Thor VM1 to power on when the vehicle is switched on and go into shut down (see note below) when the vehicle is switched off.

Note: When the vehicle is switched off, the Thor VM1 treats this event as a power button press. The default Windows setting for a power button press is to power the device off, however additional options are available on the [Advanced](#) tab of the [Power Options](#) (page 5-18) control panel.

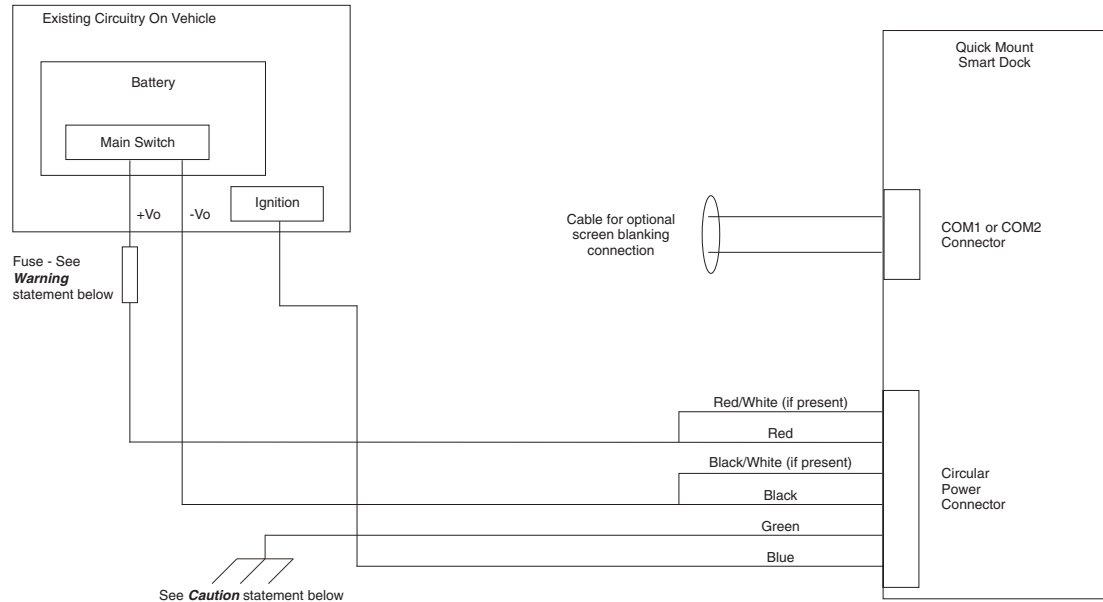

CAUTION

For battery powered vehicles:

- Red wire is connected to battery positive. If there is a red wire and a red/white wire, twist them together and connect to battery positive.
- Black wire must be connected to battery negative. If there is a black wire and a black/white wire, twist them together and connect to battery negative.
- Green wire must be connected to the vehicle chassis ground.

For internal combustion engine powered vehicles:

- Red wire is connected to battery positive. If there is a red wire and a red/white wire, twist them together and connect to battery positive.
- Black wire must be connected to battery negative. If there is a black wire and a black/white wire, twist them together and connect to battery negative.
- Green wire is connected to the vehicle chassis ground, which can also be battery negative.



WARNING

For proper and safe installation, the input power cable must be connected to a fused circuit on the vehicle. If the supply connection is made directly to the battery, the fuse should be installed in the positive lead within 5 inches of the battery's positive (+) terminal. The fused circuit requires a maximum time delay (slow blow) fuse with a current rating as noted below.

- For **12VDC** input, use a 10A slow blow fuse that has a DC voltage rating greater than 12VDC.
- For **24VDC** input, use a 6A slow blow fuse that has a DC voltage rating greater than 24VDC.
- For **36VDC** input, use a 4A slow blow fuse that has a DC voltage rating greater than 36VDC.
- For **48VDC** input, use a 3A slow blow fuse that has a DC voltage rating greater than 48VDC.

Note: For North America, a UL Listed fuse is to be used.

Auto-On Control Wiring Diagram

Auto-On must be selected on the **AutoOn** (page 5-5) control panel. The vehicle supply connections should be made to vehicle switched power to allow the terminal to automatically power-up when vehicle power is switched on or when the power switch on the back of the dock is placed in the On position. The Ignition wire is not used and should be left disconnected.

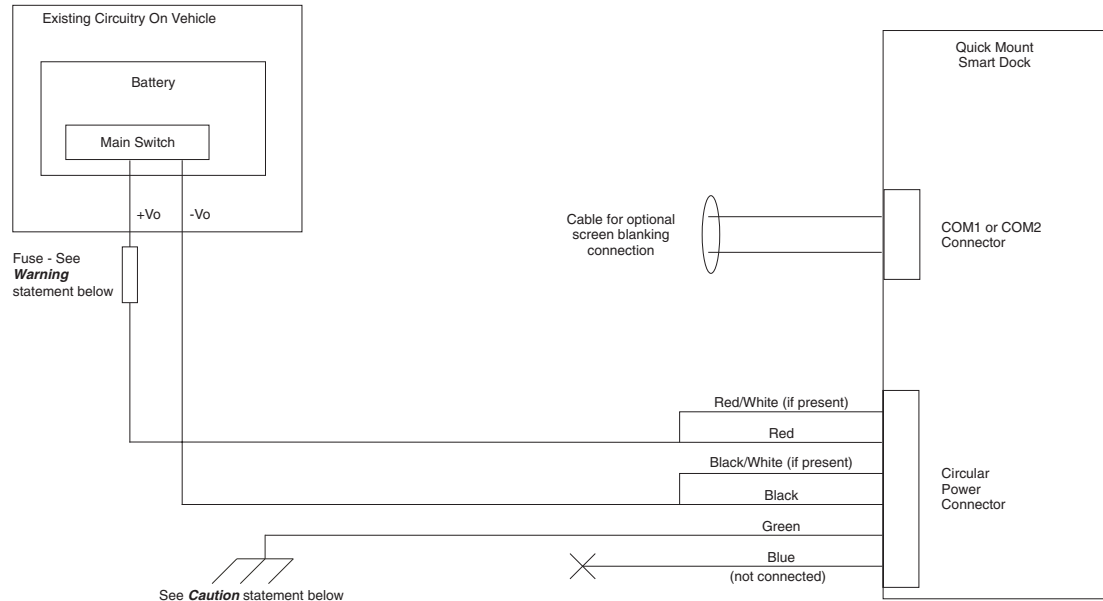

CAUTION

For battery powered vehicles:

- Red wire is connected to battery positive. If there is a red wire and a red/white wire, twist them together and connect to battery positive.
- Black wire must be connected to battery negative. If there is a black wire and a black/white wire, twist them together and connect to battery negative..
- Green wire must be connected to the vehicle chassis ground.

For internal combustion engine powered vehicles:

- Red wire is connected to battery positive. If there is a red wire and a red/white wire, twist them together and connect to battery positive.
- Black wire is connected to battery negative. If there is a black wire and a black/white wire, twist them together and connect to battery negative.
- Green wire is connected to the vehicle chassis ground, which can also be battery negative.



WARNING

For proper and safe installation, the input power cable must be connected to a fused circuit on the vehicle. If the supply connection is made directly to the battery, the fuse should be installed in the positive lead within 5 inches of the battery's positive (+) terminal. The fused circuit requires a maximum time delay (slow blow) fuse with a current rating as noted below.

- For **12VDC** input, use a 10A slow blow fuse that has a DC voltage rating greater than 12VDC.
- For **24VDC** input, use a 6A slow blow fuse that has a DC voltage rating greater than 24VDC.
- For **36VDC** input, use a 4A slow blow fuse that has a DC voltage rating greater than 36VDC.
- For **48VDC** input, use a 3A slow blow fuse that has a DC voltage rating greater than 48VDC.

Note: For North America, a UL Listed fuse is to be used.

Manual Control Wiring Diagram

Ignition wire must be left unconnected **Standard** must be selected from the [AutoOn](#) (page 5-5) control panel.

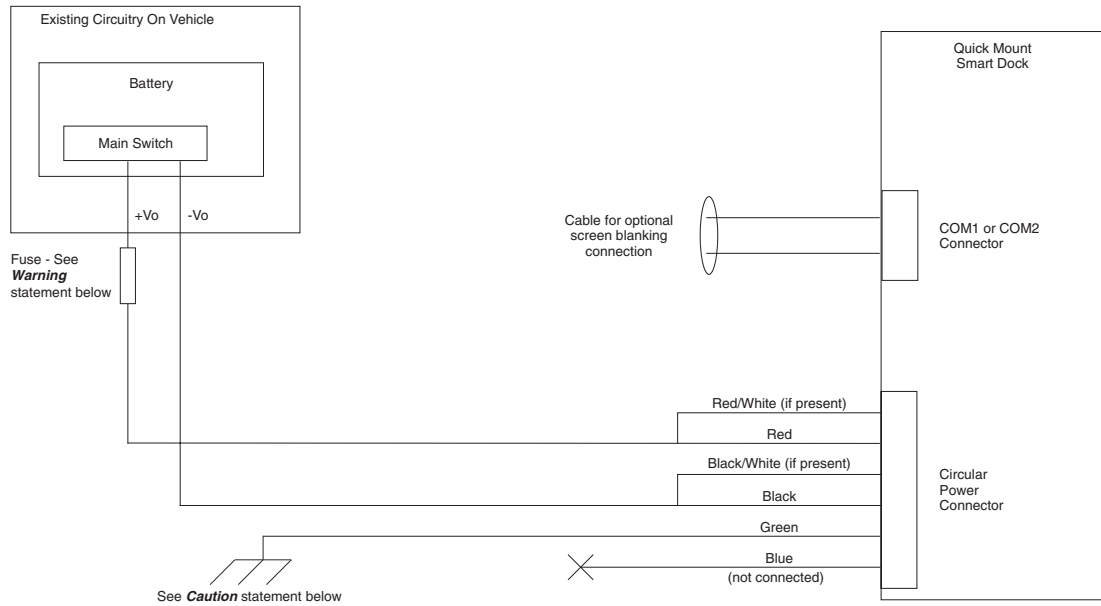

CAUTION

For battery powered vehicles:

- Red wire is connected to battery positive. If there is a red wire and a red/white wire, twist them together and connect to battery positive.
- Black wire must be connected to battery negative. If there is a black wire and a black/white wire, twist them together and connect to battery negative.
- Green wire must be connected to the vehicle chassis ground.

For internal combustion engine powered vehicles:

- Red wire is connected to battery positive. If there is a red wire and a red/white wire, twist them together and connect to battery positive.
- Black wire is connected to battery negative. If there is a black wire and a black/white wire, twist them together and connect to battery negative.
- Green wire is connected to the vehicle chassis ground, which can also be battery negative.



WARNING

For proper and safe installation, the input power cable must be connected to a fused circuit on the vehicle. If the supply connection is made directly to the battery, the fuse should be installed in the positive lead within 5 inches of the battery's positive (+) terminal. The fused circuit requires a maximum time delay (slow blow) fuse with a current rating as noted below.

- For **12VDC** input, use a 10A slow blow fuse that has a DC voltage rating greater than 12VDC.
- For **24VDC** input, use a 6A slow blow fuse that has a DC voltage rating greater than 24VDC.
- For **36VDC** input, use a 4A slow blow fuse that has a DC voltage rating greater than 36VDC.
- For **48VDC** input, use a 3A slow blow fuse that has a DC voltage rating greater than 48VDC.

Note: For North America, a UL Listed fuse is to be used.

60-144 VDC Vehicles (50-150 VDC Power Supply, Screws on Side of Lid)

This option requires DC/DC external power supply Honeywell Part no. 9000313PWRSPLY.

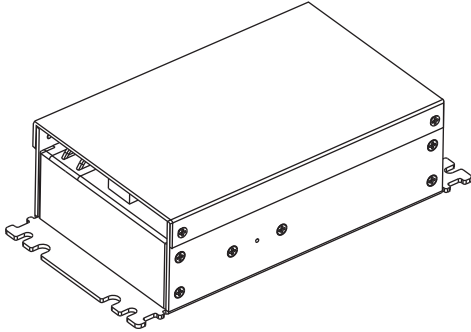

Shown With Lid Attached

- Lid is secured with screws on the side of lid.

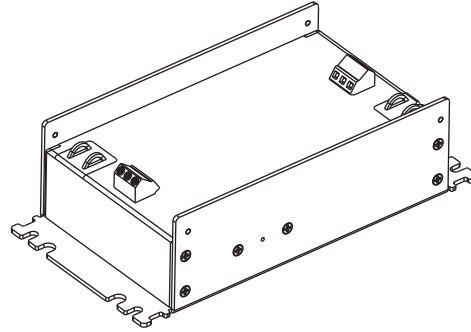

Shown With Lid Removed

- Input and output connector blocks under lid.
- One positive (Vin+), negative (Vin-) and ground (⏏) connection in input block.
- One positive (Vo+) and negative (Vo-) connection in output block.

If the DC/DC power supply does not have screws in the side of the lid, see [60-144 VDC Vehicles \(50-150 VDC Power Supply, Screws on Top of Lid\)](#) (page 4-38).



CAUTION - For installation by trained service personnel only.



CAUTION - Usage in areas where moisture can affect the power supply connections should be avoided. The power supply should be mounted in a dry location within the vehicle or placed in a suitable protective enclosure.



Use caution when routing the power cable. See [Power Cable Cautions](#) (page 4-28).



Fuse Requirements

WARNING - For proper and safe installation, the input power cable must be connected to a fused circuit on the vehicle. If the supply connection is made directly to the battery, the fuse should be installed in the positive lead within 5 inches of the battery's positive (+) terminal. The fused circuit requires a maximum time delay (slow blow) fuse with a current rating as noted below.

- For **60VDC** input, use a 6A slow blow fuse that has a DC voltage rating greater than 60VDC.
- For **72VDC** input, use a 6A slow blow fuse that has a DC voltage rating greater than 72VDC.
- For **96VDC** input, use a 4A slow blow fuse that has a DC voltage rating greater than 96VDC.
- For **108VDC** input, use a 4A slow blow fuse that has a DC voltage rating greater than 108VDC.
- For **120VDC** input, use a 4A slow blow fuse that has a DC voltage rating greater than 120VDC.
- For **132VDC** input, use a 3A slow blow fuse that has a DC voltage rating greater than 132VDC.
- For **144VDC** input, use a 3A slow blow fuse that has a DC voltage rating greater than 144VDC.

Note: For North America, a UL Listed fuse is to be used,

Power Cable Identification

The DC power cable (included with the dock) is one of the two styles below:

Power cable with **right angle connector** and **6 wires**:

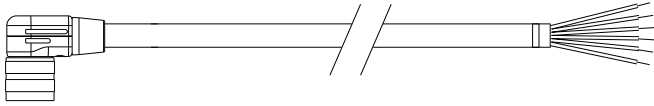

 *Twist the red and red/white wires together and twist the black and black/white wires together before connecting to vehicle power.*

Wire Color	Connection
Red (2 wires)	DC + (10-60 VDC)
Black (2 wires)	DC -
Green	Ground
Blue	Ignition Input (not used)

Power cable with **straight connector** and **4 wires**:



Wire Color	Connection
Red	DC + (10-60 VDC)
Black	DC -
Green	Ground
Blue	Ignition Input (not used)

Note: Correct electrical polarity is required for safe and proper installation. See [Wiring Diagram](#) (page 4-37) for additional wire color-coding specifics.

The Thor VM1 DC input wires (Red, Red/White DC+ and Black, Black/White DC-) and the Blue ignition input wire are galvanically isolated. The Green ground input is used for electrostatic discharge (ESD) protection.

Vehicle 50-150VDC Power Connection

Please review the [Wiring Diagram](#) (page 4-37), before beginning power cable install. The Thor VM1 must be powered off and the power cable disconnected from the Thor VM1. The last connection must be to the vehicle power source before connecting the power cable to the Thor VM1.

1. Route the cable from the Thor VM1 to the DC/DC power supply. Route the power cable the shortest way possible. The cable is rated for a maximum temperature of 105°C (221°F). When routing this cable, it should be protected from physical damage and from surfaces that might exceed this temperature. Do not expose the cable to chemicals or oil that may cause the wiring insulation to deteriorate. Always route the cable so that it does not interfere with safe operation and maintenance of the vehicle.
2. Cut the cable to length and strip the wire ends.
3. Remove the lid from the DC/DC power supply.
4. Connect the stripped end of the positive wires (red and red/white twisted together or a single red wire) to the output block. See [Power Cable Identification](#) (page 4-35).
5. Connect the stripped end of the negative wires (black and black/white twisted together or a single black wire) to the output. See [Power Cable Identification](#) (page 4-35).

Note: The input block has VIN+, VIN- and GND terminals. The output block has VO+ and VO- terminals.

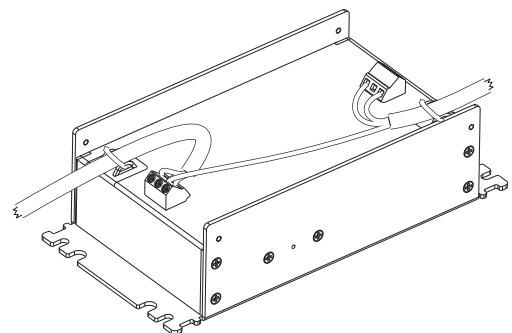

-
6. Connect the ground (green) wire from the Thor VM1 to the GND terminal on the input side of the DC/DC power supply.
 7. Route the wiring from the DC/DC power supply to the vehicle's electrical system. **Do not connect to vehicle power at this time.**
 8. Strip the wire ends and connect to the input side of the DC/DC power supply.
 9. Use looms and wire ties to secure all wiring as shown.
 10. Reattach the cover with the screws.
 11. Connect the DC/DC power supply to the vehicle's electrical system as directed below:



For battery powered vehicles:

VIN+ is connected to battery positive.

VIN- must be connected to battery negative.

GND must be connected to the vehicle chassis ground.

For internal combustion engine powered vehicles:

VIN+ is connected to battery positive.

VIN- is connected to battery negative.

GND is connected to the vehicle chassis ground, which can also be battery negative.

12. While observing the [Fuse Requirements](#) (see page 4-34) connect the power cable as close as possible to the actual battery terminals of the vehicle. When available, always connect to unswitched terminals in the vehicle fuse panel, after providing proper fusing.

ATTENTION: For uninterrupted power, electrical supply connections should not be made at any point after the ignition switch of the vehicle.

13. Use proper electrical and mechanical fastening means for terminating the cable. Properly sized "crimp" type electrical terminals are an accepted method of termination. Select electrical connectors sized for use with 18AWG (1mm²) conductors.
14. Provide mechanical support for the cable by securing it to the vehicle structure at approximately one foot intervals, taking care not to over tighten and pinch conductors or penetrate the outer cable jacket.
15. Connect the watertight connector end of the power cable to the Thor VM1 Quick Mount Smart Dock power connector by aligning the connector pins to the power connector; push down on the watertight connector and twist it to fasten securely. Flip the power switch on the back of the dock to On.
16. Secure the power cable to the Thor VM1 using the [Strain Relief Cable Clamps](#) (page 4-27).
17. [Place Thor VM1 in the Dock](#) (page 4-16)
18. If using the [Screen Blanking](#) (page 4-44) feature, install the screen blanking box or switch.
19. Press the [Power Switch](#) (page 3-5) on the back of the Thor VM1 dock.
20. Press the [Power Button](#) (page 3-5) on the front of the Thor VM1 to turn on the Thor VM1.

Once installation is complete, remember to start the Thor VM1 and configure the Auto-On behavior.

See the [AutoOn](#) (page 5-5) control panel.

Note: Ignition control is not available for trucks over 60VDC.

Wiring Diagram

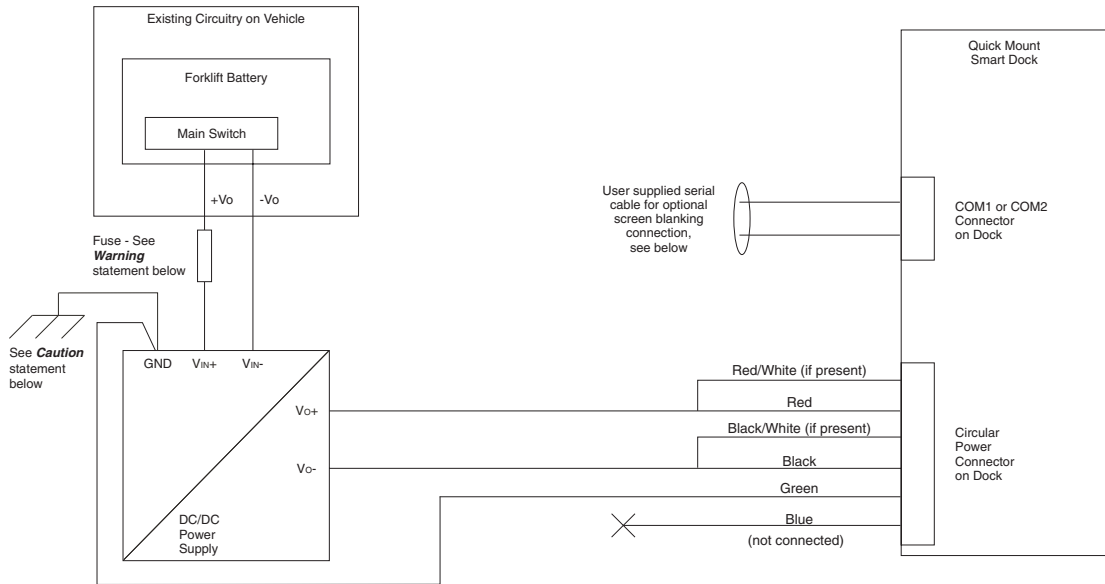

CAUTION

For battery powered vehicles:

GND must be connected to the vehicle chassis ground.

For internal combustion engine powered vehicles:

GND is connected to the vehicle chassis ground, which can also be battery negative.



WARNING

For proper and safe installation, the input power cable must be connected to a fused circuit on the vehicle. If the supply connection is made directly to the battery, the fuse should be installed in the positive (+) terminal within 5 inches of the battery's positive (+) terminal. The fused circuit requires a maximum time delay (slow blow) fuse with a current rating as noted below.

- For **60VDC** input, use a 6A slow blow fuse that has a DC voltage rating greater than 60VDC.
- For **72VDC** input, use a 6A slow blow fuse that has a DC voltage rating greater than 72VDC.
- For **96VDC** input, use a 4A slow blow fuse that has a DC voltage rating greater than 96VDC.
- For **108VDC** input, use a 4A slow blow fuse that has a DC voltage rating greater than 108VDC.
- For **120VDC** input, use a 4A slow blow fuse that has a DC voltage rating greater than 120VDC.
- For **132VDC** input, use a 3A slow blow fuse that has a DC voltage rating greater than 132VDC.
- For **144VDC** input, use a 3A slow blow fuse that has a DC voltage rating greater than 144VDC.

Note: For North America, a UL Listed fuse is to be used

60-144 VDC Vehicles (50-150 VDC Power Supply, Screws on Top of Lid)

This option requires DC/DC power supply Honeywell Part no. VX89303PWRSPPLY, shown below.

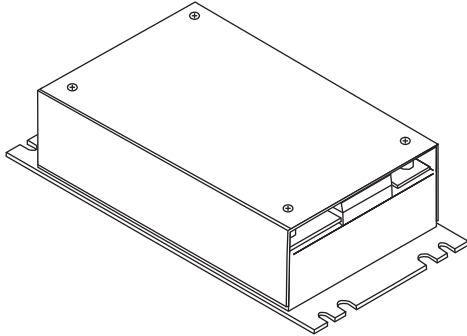

Shown With Lid Attached

- Lid is secured with screws on the top of lid.

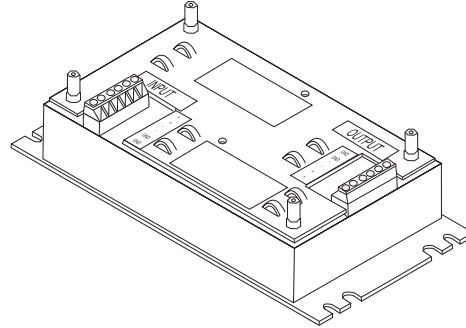

Shown With Lid Removed

- Input and output connector blocks under lid.
- Two positive (+), negative (-) and ground (⊖) connections per terminal block

If the DC/DC power supply does not have screws in the top of the lid, see [60-144 VDC Vehicles \(50-150 VDC Power Supply, Screws on Side of Lid\)](#) (page 4-34).



CAUTION - For installation by trained service personnel only.



CAUTION - The VX89303PWRSPPLY power supply is sealed per IPXX. Usage in areas where moisture can affect the power supply connections should be avoided. The power supply should be mounted in a dry location within the vehicle or placed in a suitable protective enclosure.



Use caution when routing the power cable. See [Power Cable Cautions](#) (page 4-28).



Fuse Requirements

WARNING - For proper and safe installation, the input power cable must be connected to a fused circuit on the vehicle. If the supply connection is made directly to the battery, the fuse should be installed in the positive lead within 5 inches of the battery's positive (+) terminal. The fused circuit requires a maximum time delay (slow blow) fuse with a current rating as noted below.

- For **60VDC** input, use a 6A slow blow fuse that has a DC voltage rating greater than 60VDC.
- For **72VDC** input, use a 6A slow blow fuse that has a DC voltage rating greater than 72VDC.
- For **96VDC** input, use a 4A slow blow fuse that has a DC voltage rating greater than 96VDC.
- For **108VDC** input, use a 4A slow blow fuse that has a DC voltage rating greater than 108VDC.
- For **120VDC** input, use a 4A slow blow fuse that has a DC voltage rating greater than 120VDC.
- For **132VDC** input, use a 3A slow blow fuse that has a DC voltage rating greater than 132VDC.
- For **144VDC** input, use a 3A slow blow fuse that has a DC voltage rating greater than 144VDC.

Note: For North America, a UL Listed fuse is to be used.

Power Cable Identification

The DC power cable (included with the dock) is one of the two styles below:

Power cable with **right angle connector** and **6 wires**:

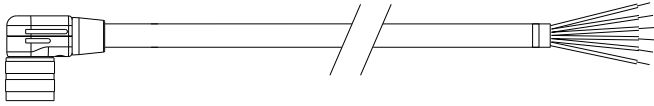

Twist the red and red/white wires together and twist the black and black/white wires together before connecting to vehicle power.

Wire Color	Connection
Red (2 wires)	DC + (10-60 VDC)
Black (2 wires)	DC -
Green	Ground
Blue	Ignition Input (not used)

Power cable with **straight connector** and **4 wires**:

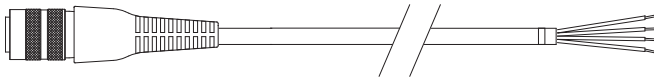

Wire Color	Connection
Red	DC + (10-60 VDC)
Black	DC -
Green	Ground
Blue	Ignition Input (not used)

Note: Correct electrical polarity is required for safe and proper installation. See [Wiring Diagram](#) (page 4-41) for additional wire color-coding specifics.

The Thor VM1 DC input wires (Red, Red/White DC+ and Black, Black/White DC-) and the Blue ignition input wire are galvanically isolated. The Green ground input is used for electrostatic discharge (ESD) protection.

Vehicle 50-150VDC Power Connection

Please review the [Wiring Diagram](#) (page 4-41), before beginning power cable install. The Thor VM1 must be powered off and the power cable disconnected from the Thor VM1. The last connection must be to the vehicle power source before connecting the power cable to the Thor VM1.

1. Route the cable from the Thor VM1 to the DC/DC power supply. Route the power cable the shortest way possible. The cable is rated for a maximum temperature of 105°C (221°F). When routing this cable, it should be protected from physical damage and from surfaces that might exceed this temperature. Do not expose the cable to chemicals or oil that may cause the wiring insulation to deteriorate. Always route the cable so that it does not interfere with safe operation and maintenance of the vehicle.
2. Cut the cable to length and strip the wire ends.
3. Remove the lid from the DC/DC power supply.
4. Connect the stripped end of the positive wires (red and red/white twisted together or a single red wire) to the output block. See [Power Cable Identification](#) (page 4-39).
5. Connect the stripped end of the negative wires (black and black/white twisted together or a single black wire) to the output. See [Power Cable Identification](#) (page 4-39).

Note: The input and output blocks each have two + (plus), two – (minus) and two ⊕ (ground) connectors. Either connector in the block can be used to connect the matching polarity wire.

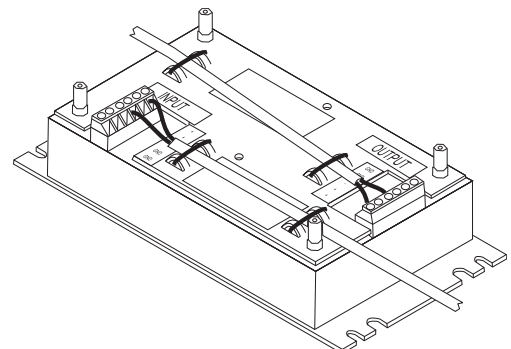

-
6. Route the wiring from the DC/DC power supply to the vehicle's electrical system. **Do not connect to vehicle power at this time.**
 7. Strip the wire ends and connect to the input side of the DC/DC power supply.
 8. Use looms and wire ties to secure all wiring as shown.
 9. Reattach the cover with the screws.
 10. Connect the DC/DC power supply to the vehicle's electrical system as directed below



For battery powered vehicles:

- + is connected to battery positive.
- must be connected to battery negative.:
- ⊖ must be connected to the vehicle chassis ground.

For internal combustion engine powered vehicles:

- + is connected to battery positive.
- is connected to battery negative.
- ⊖ is connected to the vehicle chassis ground, which can also be battery negative.

11. While observing the [Fuse Requirements](#) (see page 4-38), connect the power cable as close as possible to the actual battery terminals of the vehicle. When available, always connect to unswitched terminals in the vehicle fuse panel, after providing proper fusing.

ATTENTION: For uninterrupted power, electrical supply connections should not be made at any point after the ignition switch of the vehicle.

12. Use proper electrical and mechanical fastening means for terminating the cable. Properly sized "crimp" type electrical terminals are an accepted method of termination. Select electrical connectors sized for use with 18AWG (1mm²) conductors.
13. Provide mechanical support for the cable by securing it to the vehicle structure at approximately one foot intervals, taking care not to over tighten and pinch conductors or penetrate the outer cable jacket.
14. Connect the watertight connector end of the power cable to the Thor VM1 Quick Mount Smart Dock power connector by aligning the connector pins to the power connector; push down on the watertight connector and twist it to fasten securely. Flip the power switch on the back of the dock to On.
15. Secure the power cable to the Thor VM1 using the [Strain Relief Cable Clamps](#) (page 4-27).
16. [Place Thor VM1 in the Dock](#) (page 4-16)
17. If using the [Screen Blanking](#) (page 4-44) feature, install the screen blanking box or switch.
18. Press the [Power Switch](#) (page 3-5) on the back of the Thor VM1 dock.
19. Press the [Power Button](#) (page 3-5) on the front of the Thor VM1 to turn on the Thor VM1.

Once installation is complete, remember to start the Thor VM1 and configure the Auto-On behavior.

See the [AutoOn](#) (page 5-5) control panel.

Note: Ignition control is not available for trucks over 60VDC.

Wiring Diagram

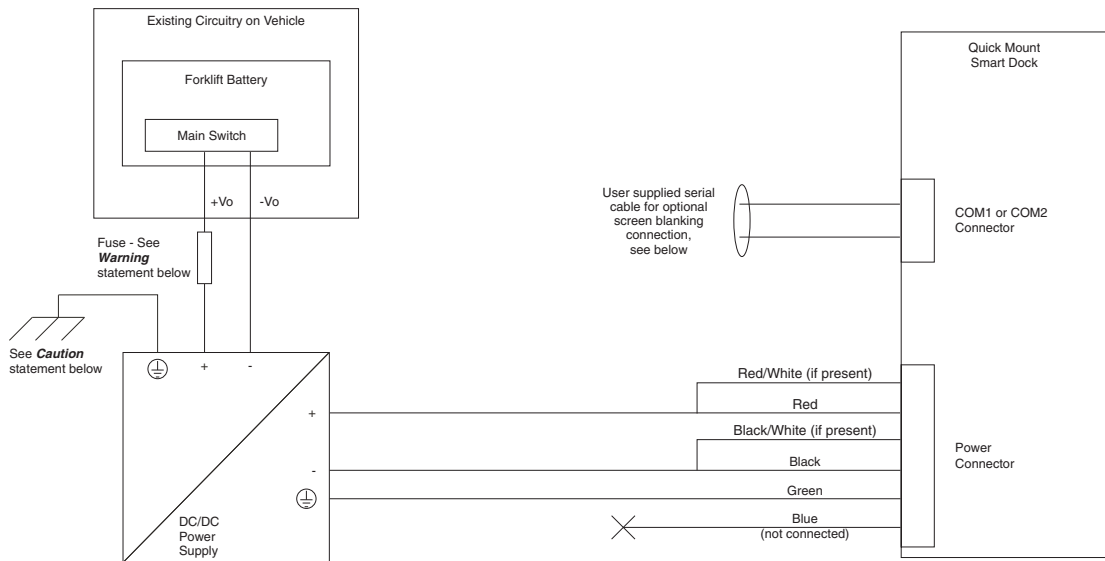

CAUTION

For battery powered vehicles:

⊕ must be connected to the vehicle chassis ground.

For internal combustion engine powered vehicles:

⊕ is connected to the vehicle chassis ground, which can also be battery negative.



WARNING

For proper and safe installation, the input power cable must be connected to a fused circuit on the vehicle. If the supply connection is made directly to the battery, the fuse should be installed in the positive (+) terminal within 5 inches of the battery's positive (+) terminal. The fused circuit requires a maximum time delay (slow blow) fuse with a current rating as noted below.

- For **60VDC** input, use a 6A slow blow fuse that has a DC voltage rating greater than 60VDC.
- For **72VDC** input, use a 6A slow blow fuse that has a DC voltage rating greater than 72VDC.
- For **96VDC** input, use a 4A slow blow fuse that has a DC voltage rating greater than 96VDC.
- For **108VDC** input, use a 4A slow blow fuse that has a DC voltage rating greater than 108VDC.
- For **120VDC** input, use a 4A slow blow fuse that has a DC voltage rating greater than 120VDC.
- For **132VDC** input, use a 3A slow blow fuse that has a DC voltage rating greater than 132VDC.
- For **144VDC** input, use a 3A slow blow fuse that has a DC voltage rating greater than 144VDC.

Note: For North America, a UL Listed fuse is to be used.

VX6 / VX7 Adapter Cable

An adapter cable is available to attach the Thor VM1 to a vehicle previously equipped with a VX6/VX7 DC power cable. The adapter cable has a 5-pin connector to match with the VX6/VX7 power supply cable on one end and a 6-pin connector to match to the Thor VM1 on the other end. This section assumes the VX6/VX7 power cable is properly connected to vehicle power. Refer to the VX6 or VX7 Vehicle Mounting Reference Guide for details.



CAUTION - Because the Thor supports 10-60 VDC power input, **verify input voltages** before using this adapter cable with an existing VX6 or VX7 power connection installation.

To Power Connector on Dock



To VX6/VX7 Power Supply Cable

When this adapter cable is used, there is no provision for an ignition switch input. Therefore the vehicle ignition monitoring function is not available when using this cable.

Connect to VX6 / VX7 Power Cable

1. Connect the cable to the Thor VM1 power cable by aligning the connector pins to the power connector; push down on the watertight connector and twist it to fasten securely.
2. The cable is rated for a maximum temperature of 105°C (221°F). Therefore, routing this cable it should be protected from physical damage and from surfaces that might exceed this temperature. Cable should be protected from physical damage from moving parts. Do not expose the cable to chemicals or oil that may cause the wiring insulation to deteriorate. Always route the cable so that it does not interfere with safe operation and maintenance of the vehicle.
3. Provide mechanical support for the cable by securing it to the vehicle structure at approximately one foot intervals, taking care not to over tighten and pinch conductors or penetrate outer cable jacket.
4. Connect the watertight connector end of the power cable to the Thor VM1 Quick Mount Smart Dock power connector by aligning the connector pins to the power connector; push down on the watertight connector and twist it to fasten securely.
5. Secure the power cable to the Thor VM1 using the [Strain Relief Cable Clamps](#) (page 4-27).
6. [Place Thor VM1 in the Dock](#) (page 4-16)
7. If using the [Screen Blanking](#) (page 4-44) feature, install the screen blanking box or switch.
8. Press the [Power Switch](#) (page 3-5) on the back of the Thor VM1 dock.
9. Press the [Power Button](#) (page 3-5) on the front of the Thor VM1 to turn on the Thor VM1.

Thor VX8 / Thor VX9 Adapter Cable

An adapter cable is available to attach the Thor VM1 to a vehicle previously equipped with a VX8/VX9 DC power cable. The adapter cable has a 6-pin connector to match the VX8/VX9 power supply cable on one end and a 6-pin connector to match the Thor VM1 on the other end. The cable also has bare wires for ground and ignition sense connection plus a D9 cable to connect to a COM port on the Thor VM1 dock to provide a screen blanking signal. This section assumes the VX8/VX9 power cable is properly connected to vehicle power. Refer to the VX8 or VX9 Vehicle Mounting Reference Guide for details.

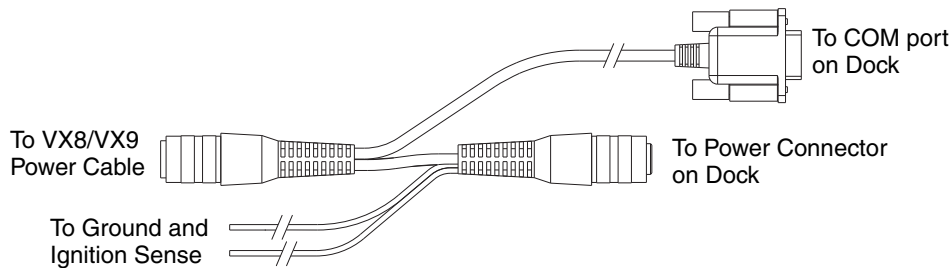

Connect to Thor VX8 / VX9 Power Cable

1. Connect the cable to the Thor VX8/VX9 power cable by aligning the connector pins to the power connector; push down on the watertight connector and twist it to fasten securely.
2. Connect the green wire to vehicle ground:



For battery powered vehicles:

The green wire must be connected to the vehicle chassis ground.

For internal combustion engine powered vehicles:

The green wire is connected to the vehicle chassis ground, which can also be battery negative.

3. If ignition control will be used, connect the blue wire to an ignition switched circuit (less than 1mA over input voltage range). If ignition control is not used, the blue wire can be left disconnected,
4. If the VX8/VX9 cable is connected to a screen blanking box or switch, connect the D9 connector to a COM port on the dock.
5. The cable is rated for a maximum temperature of 105°C (221°F). Therefore, when routing this cable it should be protected from physical damage and from surfaces that might exceed this temperature. Cable should be protected from physical damage from moving parts. Do not expose the cable to chemicals or oil that may cause the wiring insulation to deteriorate. Always route the cable so that it does not interfere with safe operation and maintenance of the vehicle.
6. Provide mechanical support for the cable by securing it to the vehicle structure at approximately one foot intervals, taking care not to over tighten and pinch conductors or penetrate outer cable jacket.
7. Connect the watertight connector end of the power cable to the Thor VM1 Quick Mount Smart dock power connector by aligning the connector pins to the power connector; push down on the watertight connector and twist it to fasten securely.
8. Secure the power cable to the Thor VM1 using the [Strain Relief Cable Clamps](#) (page 4-27).
9. [Place Thor VM1 in the Dock](#) (page 4-16)
10. If using the [Screen Blanking](#) (page 4-44) feature, install the screen blanking box or switch if not previously installed.
11. Press the [Power Switch](#) (page 3-5) on the back of the Thor VM1 dock.
12. Press the [Power Button](#) (page 3-5) on the front of the Thor VM1 to turn on the Thor VM1.

Screen Blanking

Prerequisite: The steps outlined in either [12-48 VDC Vehicles \(10-60 VDC Direct Connection\)](#) (page 4-29), [60-144 VDC Vehicles \(50-150 VDC Power Supply, Screws on Side of Lid\)](#) (page 4-34) or [60-144 VDC Vehicles \(50-150 VDC Power Supply, Screws on Top of Lid\)](#) (page 4-38) have been completed.

Screen blanking is accomplished by either a Screen Blanking Box or a user supplied switch.



CAUTION - For installation by trained service personnel only.



CAUTION - For proper and safe installation, the input power lead to the Screen Blanking Box requires a 3 Amp maximum time delay (slow blow) high interrupting rating fuse. Note: For North America, a UL Listed fuse is to be used.

Screen Blanking Cable

Refer to Screen Control (in the Windows Control Panel) to configure the Thor VM1 for screen blanking.

When routing any additional cables for screen blanking:

- Route the cable the shortest way possible removing any left-over cable
- Fuses and cabling are user supplied. Therefore, route these cables so they are protected from physical damage and from surfaces that might exceed the cable's rated temperature threshold.
- Cable should be protected from physical damage from moving parts
- Do not expose the cable to chemicals or oil that may cause the wiring insulation to deteriorate
- Always route the cable so that it does not interfere with safe operation and maintenance of the vehicle.
- Provide mechanical support for the cable by securing it to the vehicle structure at approximately one foot intervals, taking care not to over tighten and pinch conductors or penetrate outer cable jacket.

Honeywell Screen Blanking Box Cable

An optional Honeywell Screen Blanking Box Cable is available.

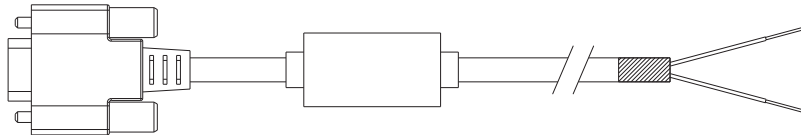

DB9 Female	Function with Screen Blanking Box	Wire color
1 -6, 9	Not Used	
7 (RTS)	Connected to Screen Blanking Box, unswitched side	Black (see note)
8 (CTS)	Connected to Screen Blanking Box, switched side	Gray (see note)

Note: Wire colors only apply to optional Honeywell Screen Blanking Box Cable, VM1080CABLE. Wire colors may vary in a user-supplied cable.

The optional Honeywell Screen Blanking Box Cable, VM1080CABLE, is installed as follows:

1. Connect the gray wire of the cable to the switched side of the Screen Blanking Box.
2. Connect the black wire of the cable to the unswitched side of the Screen Blanking Box.
3. Connect the D9 serial connector to either COM1 or COM2 serial port on the Thor VM1 Quick Mount Smart Dock.

User-Supplied Cable

A user-supplied cable can be used as well. Pins 7 and 8 must be connected as detailed below. No other pins are to be connected.

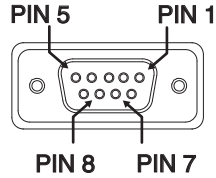

DB9 Female	Function with Screen Blanking Box	Function with Switch
1 -6, 9	Not Used	Not Used
7 (RTS)	Connected to Screen Blanking Box, unswitched side	Connected to Switch
8 (CTS)	Connected to Screen Blanking Box, switched side	Connected to Switch

The user-supplied cable is installed as follows:

1. Connect the wire from Pin 8 of the cable to the switched side of the Screen Blanking Box or to a user-supplied switch.
2. Connect the wire from Pin 7 of the cable to the unswitched side of the Screen Blanking Box or to a user-supplied switch.
3. Connect the D9 serial connector to either COM1 or COM2 serial port on the Thor VM1 Quick Mount Smart Dock.

Screen Blanking Box

Screen Blanking Box Terminal	Connection
12-xxV	Input from vehicle motion sensing circuitry. Please refer to label on Screen Blanking Box for allowable voltage input range.
GND	DC -
	These two terminals are for connecting a serial cable: <ul style="list-style-type: none"> • If using an optional Honeywell screen blanking cable, VM1080CABLE, connect the <i>gray</i> wire to the <i>switched</i> side of the connection and connect the <i>black</i> wire to the <i>unswitched</i> side. • If using a user-supplied cable, the cable must be constructed so that Pin 7 (RTS) connects to <i>switched</i> side of the connection and Pin 8 (CTS) connects to the <i>unswitched</i> side.

It is assumed that the motion sensing circuitry in the illustrations below is powered by internal vehicle circuitry.

Please refer to the appropriate illustration below for Screen Blanking Box wiring diagrams.

CAUTION - Do not exceed the maximum input voltage, either 60 or 72VDC, specified on the Screen Blanking Box label when using this configuration.

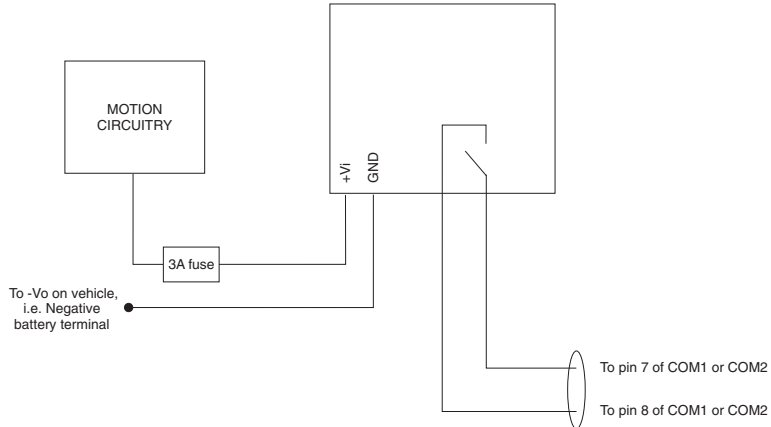

Note: The black and gray wire colors in the illustration only apply to the optional Honeywell Screen Blanking Box Cable, VM1080CABLE. The wire colors may be different in a user-supplied cable.

Screen Blanking with Switch

In applications where it is impractical to use the screen blanking box due to vehicle voltage or lack of a motion sensing signal, screen blanking can be controlled via a user supplied switch or relay that provides an electrical conductive connection on vehicle motion.

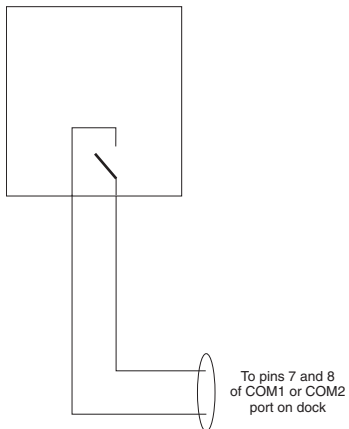

Pins 7 and 8 must be connected as shown in the illustration above. No other pins are to be connected.

External AC/DC Power Supply

The optional external AC/DC power supply is for use in environments, such as an office, where DC power is not available.

Note: The Honeywell-approved AC/DC Power Supply and Adapter Cable are only intended for use in a 25°C (77°F) maximum ambient temperature environment.

In North America, this unit is intended for use with a UL Listed ITE power supply with output rated 10 – 60 VDC, minimum 15W. Outside North America, this unit is intended for use with an IEC certified ITE power supply with output rated 10 – 60 VDC, minimum 15W.

The external power supply may be connected to either a 120V, 60Hz supply or, outside North America, to a 230V, 50Hz supply, using the appropriate detachable cordset. In all cases, connect to a properly grounded source of supply provided with maximum 15 Amp overcurrent protection (10 Amp for 230V circuits).

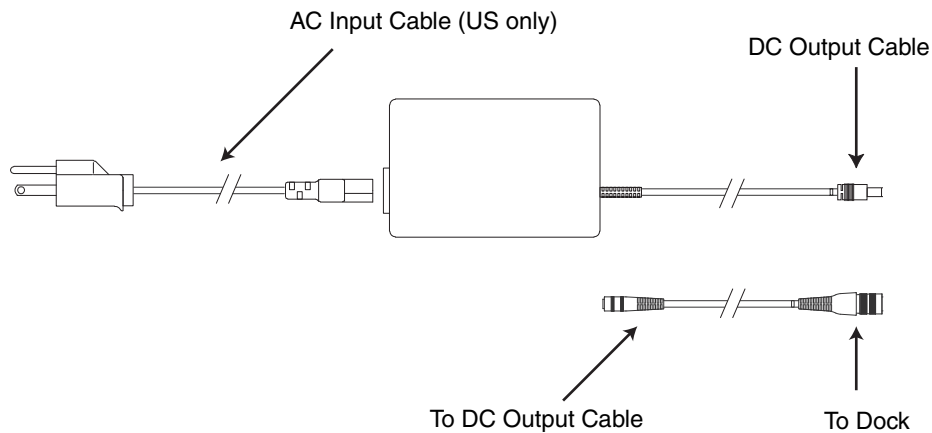

Connect External Power Supply

1. Connect the provided detachable cordset (US only, all others must order cable separately) to the external power supply (IEC 320 connector).
2. Plug cordset into appropriate, grounded, electrical supply receptacle (AC mains).
3. Connect the DC Output Cable end to the corresponding connector on the Adapter Cable.
4. Connect the watertight connector end of the Adapter Cable to the Thor VM1 Quick Mount Smart Dock Power Connector by aligning the connector pins to the power connector; push down on the watertight connector and twist it to fasten securely.
5. Press the [Power Switch](#) (page 3-5) on the back of the Thor VM1 dock.
6. Press the [Power Button](#) (page 3-5) on the front of the Thor VM1 to turn on the Thor VM1.

Connect USB Host

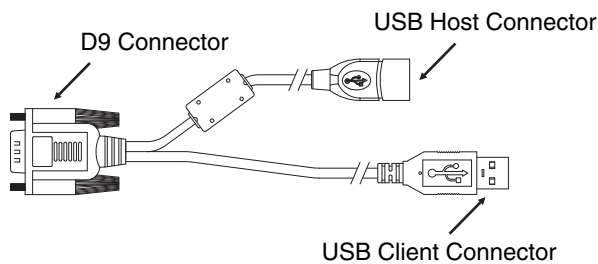

See [USB Connector](#) (page 8-5) for connector pinouts.

1. Seat the D9 connector firmly over the USB Connector on the Quick Mount Smart Dock.
2. Tighten the thumbscrews in a clockwise direction. Do not over tighten.
3. The USB-host connector provides a connector for a USB device such as a USB thumb drive.
4. Secure the cables to the Thor VM1 with [Strain Relief Cable Clamps](#) (page 4-27).

Connect USB Client

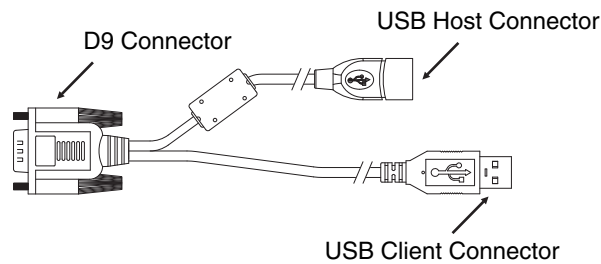

Note: USB client connection is not used on Thor VM1 with a Windows Embedded Standard operating system.

Connect Serial Device

Note: Pin 9 of the COM port is configured to provide +5V.

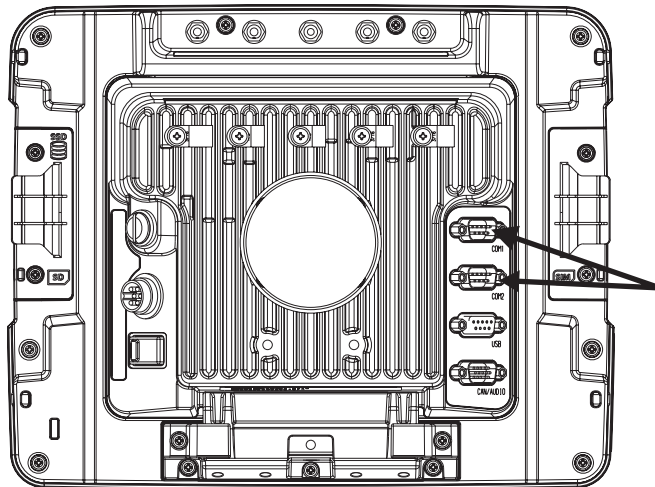

See [COM1 and COM2 Connector](#) (page 8-4) for connector pinouts.

1. Seat the cable end connector firmly over the serial COM port on the Quick Mount Smart Dock.
2. Turn the thumbscrews in a clockwise direction. Do not over tighten.
3. Secure the cables to the Thor VM1 with [Strain Relief Cable Clamps](#) (page 4-27).
4. Connect the other cable end to the desired serial device.

Connect a Tethered Scanner

1. The scanner cable is attached to either the COM1 or COM2 port on the Quick Mount Smart Dock.
2. Connect the serial cable for the scanner as directed above.
3. When the Thor VM1 is powered on, it provides power to the serial scanner.
4. Configure the Data Collection (DC) Wedge to manipulate scanned data as desired.

Connect Headset Cable

The CANbus/Audio connector supports a headset adapter cable or a CANbus cable. The Thor VM1 does not support connecting audio and CANbus simultaneously.

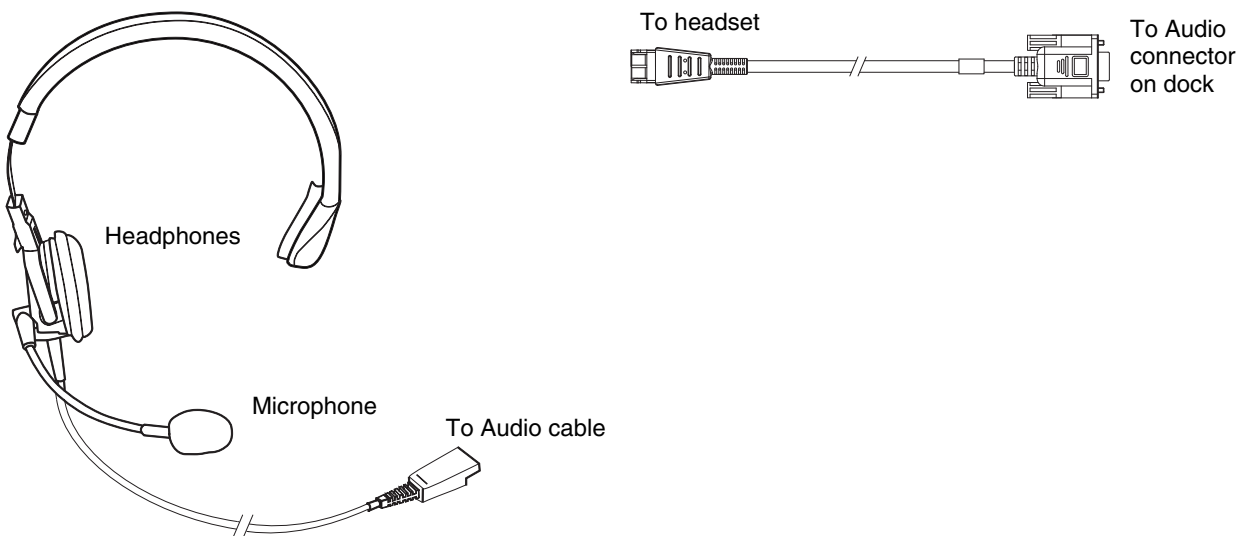

See [CANbus / Audio Connector](#) (page 8-6) for connector pinouts.

1. Seat the D15 cable end connector firmly over the CANbus/Audio Connector on the Quick Mount Smart Dock.
2. Tighten the thumbscrews in a clockwise direction. Do not over tighten.

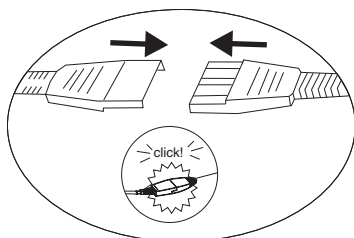

3. Slide the cable ends together until they click shut. Do not twist or bend the connectors. The Thor VM1 internal microphone and speakers are automatically disabled when the headset is connected.

Adjust Headset / Microphone and Secure Cable

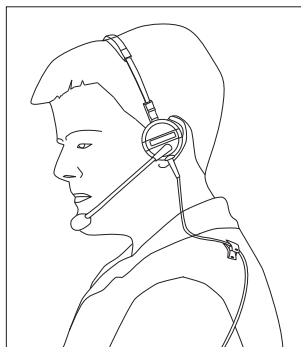

The headset consists of an earpiece, a microphone, a clothing clip and a cable.

-
1. Do not twist the microphone boom when adjusting the microphone. The microphone should be adjusted to be about two finger widths from your mouth.
 2. Make sure the microphone is pointed at your mouth. Note the small “Talk” label near the mouthpiece. Make sure the Talk label is in front of your mouth. The microphone cable can be routed over or under clothing.
 3. Follow the safety guidelines below when wearing the headset.

Under Clothing

- Leave the cable exposed only at the top of the collar.
- Be sure to leave a small loop of cable to allow movement of your head.

Over Clothing

- Use clothing clips to hold the cable close to your body.
- Tuck the cable under the belt, but leave a small loop where it goes under the belt.
- Do not wear the cable on the front of your body. It may get in your way or get caught on protruding objects.

Connect CANbus Cable

The CANbus/Audio connector supports a headset adapter cable or a CANbus Y cable. The Thor VM1 does not support connecting audio and CANbus simultaneously.

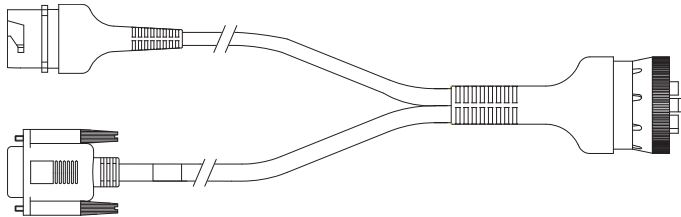

See [CANbus / Audio Connector](#) (page 8-6) for connector pinouts.

1. Seat the D15 cable end connector firmly over the CANbus/Audio Connector on the Quick Mount Smart Dock.
2. Tighten the thumbscrews in a clockwise direction. Do not over tighten.
3. The CANbus Y cable has a 9 pin F SAE J1939 (Deutsch) and 9 pin M SAE J1939 (Deutsch) connector. Connect the appropriate cable connector as needed.

Install Remote Antenna

Remote antennas are available for the 802.11 WLAN radio, the WWAN radio and the GPS.

802.11 Remote Mount Antenna

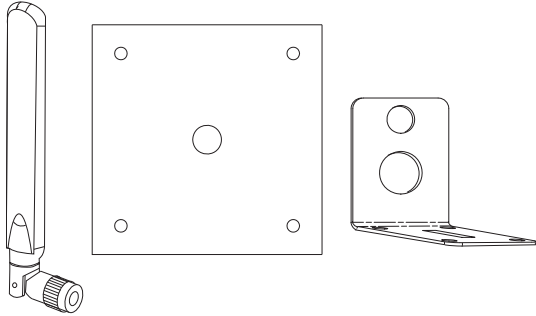

The Remote Antenna Installation Kit consists of two brackets (base plate and right angle), cable, and antenna. Tools are not included.

The desired remote antenna bracket is mounted on the top of a forklift, truck or other vehicle and cabled to the Thor VM1 inside the vehicle.

The Vehicle Remote Mount Antenna cannot be used by devices with an internal antenna.

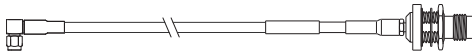

Components and Mounting Diagram

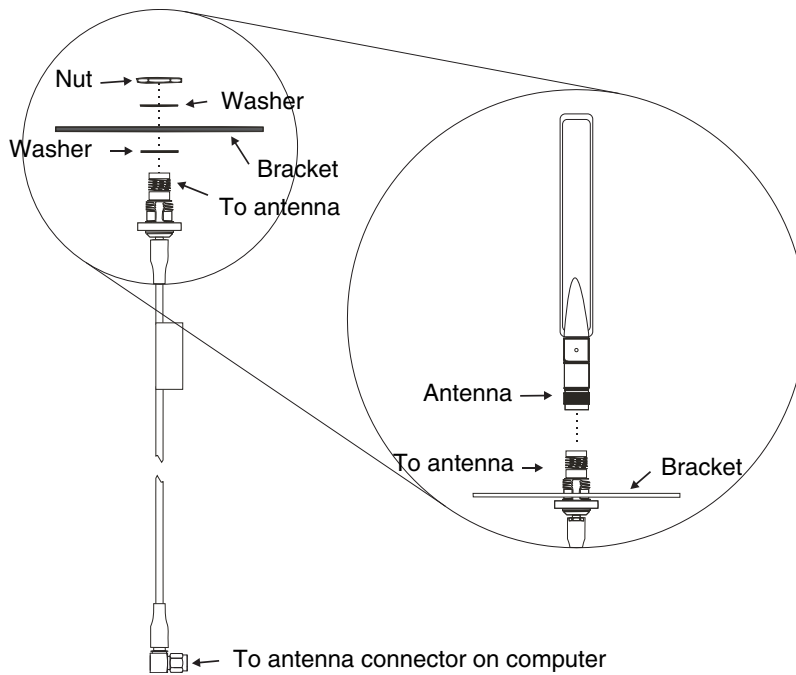

Typical Installation

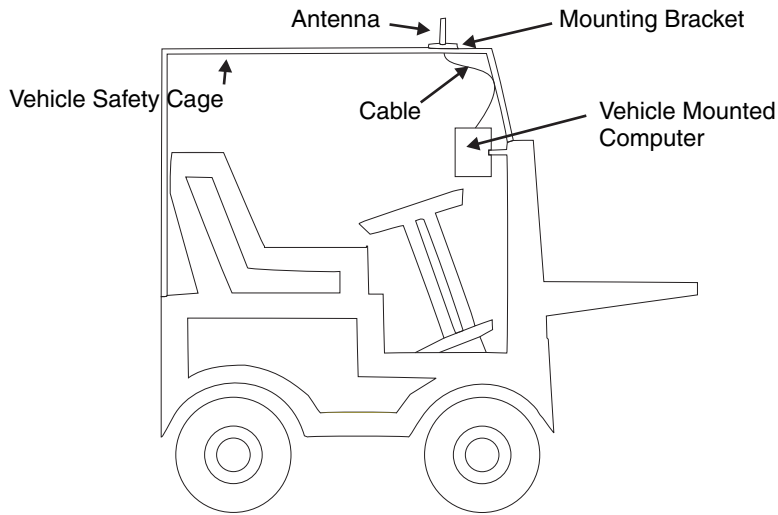

Mounting Instructions

1. Attach and secure the desired mounting bracket to the highest point on the safety cage, following these precautions:
 - The plate must be mounted so the antenna is not damaged while the vehicle or any of its parts are moving.
 - The antenna mounting portion of the bracket must be parallel to the floor.
 - If using two antennas, they must be mounted at least 12 inches (304.8mm) apart.
2. Attach the female connector of the coaxial cable to the antenna connector on the vehicle mounted Thor VM1.
3. Secure the whip antenna to the mounting bracket.
4. Connect the antenna cable to the whip antenna.
5. Use cable ties to secure the coaxial cable to the vehicle as necessary. Make sure the cable is routed so it is not damaged by any moving parts of the vehicle.
6. Connect the cable to the antenna connector (Wi-Fi Main or Wi-Fi Aux) on the Thor VM1. If only one antenna is used, be sure to connect it to the Wi-Fi Main connector.
7. Repeat the steps above for the second 802.11 antenna.

WAN Remote Mount Antenna

The WAN remote mount antenna can be either a magnetic mount or an adhesive mount antenna.

Magnetic Mount WAN Antenna

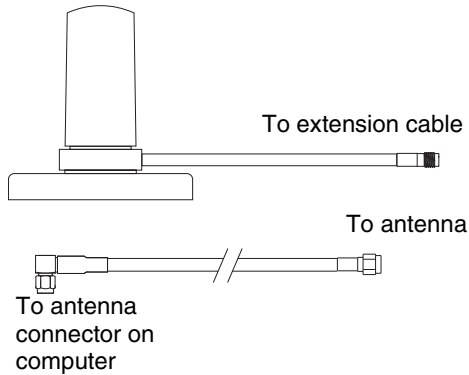

Adhesive Mount WAN Antenna

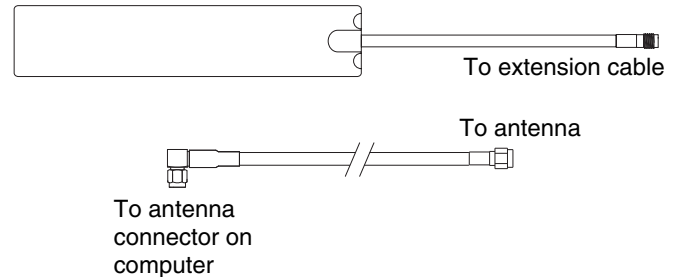

The Remote Antenna Installation Kit consists of the WAN antenna and an extension cable. The remote antenna is mounted on the top of a forklift, truck or other vehicle and cabled to the Thor VM1 inside the vehicle.

1. Locate a mounting position on highest point on the vehicle, following these precautions:
 - The antenna must be mounted so the antenna is not damaged while the vehicle or any of its parts are moving.
2. Clean the area where the antenna is to be mounted.
3. If using an adhesive mount antenna, remove the protective backing paper from the adhesive on the antenna.
4. Position the antenna on the vehicle.
5. Attach the one end of the coaxial cable to the antenna and the other end to the Mobile Net WWAN connector on the vehicle mounted Thor VM1.
6. Use cable ties to secure the coaxial cable to the vehicle as necessary. Make sure the cable is routed so it is not damaged by any moving parts of the vehicle.

GPS Remote Mount Antenna

The external GPS antenna is an adhesive mount antenna.

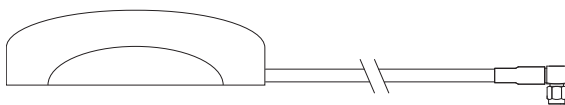

The Remote Antenna Installation Kit consists of the antenna and an integrated cable. The remote antenna is mounted on the top of a forklift, truck or other vehicle and cabled to the Thor VM1 inside the vehicle.

1. Locate a mounting position on highest point on the vehicle, following these precautions:
 - The antenna must be mounted so the antenna is not damaged while the vehicle or any of its parts are moving.
2. Clean the area where the antenna is to be mounted.
3. Remove the protective backing paper from the adhesive on the antenna and position the antenna on the vehicle.
4. Attach the connector on the coaxial cable to the GPS antenna connector on the vehicle mounted Thor VM1.
5. Use cable ties to secure the coaxial cable to the vehicle as necessary. Make sure the cable is routed so it is not damaged by any moving parts of the vehicle.

Apply Touch Screen Protective Film

The optional Thor VM1 touch screen protective film is shipped in packs of 10. The protective film is flexible and treated with an anti-glare coating on the outer surface.

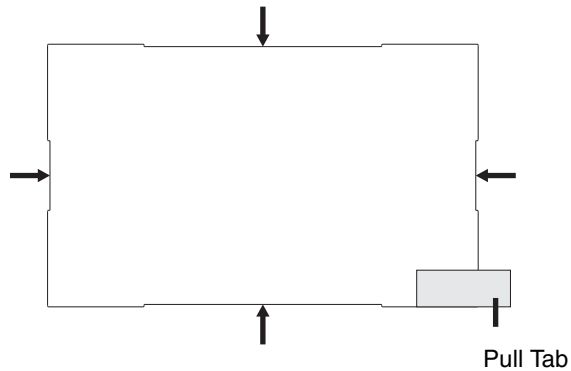

The protective film is slightly larger than the Thor VM1 touch screen, however the notches on the edge of the protective film (indicated by the arrows) correspond to the display size of the Thor VM1. The protective film is not adhesive. The corner edges are designed to fit between the Thor VM1 display and the display housing to hold the protective film in place.

A protective backing is applied to the rear surface of the protective film. A pull tab is attached to the protective backing for easy removal of the protective backing from the film.

Installation

1. Make sure the touch screen is clean and dry before installation. See [Cleaning](#) (page 4-16) for instructions on suitable cleaning agents.
2. Pull the release tab to separate the protective backing from the rear of the protective film. Avoid touching the rear side of the protective film while removing the liner.
3. Place the rear side of the protective film against the Thor VM1 display, roughly centering the protective film over the display.
4. Slide the protective film until one corner can be slid back between the touch screen and the display housing as the protective film is re-centered on the display. It may be necessary to press the edges of the protective film against the display to ensure the entire edge slides under the display housing. It is easiest to start with one of the bottom corners.
5. Slide the protective film away from the other bottom corner. The film may bulge slightly away from the Reference Guide as it is being slid. Only slide the protective film enough so that the protective film can slide under the display housing on that corner when the protective film is returned to center.
6. Repeat with each of the top corners, sliding the protective film away from the corner just enough that the protective film can slide under the display housing when the protective film is returned to center.
7. It may be necessary to flex the protective film during the install, however use care not to flex the protective film so much that the protective film kinks.
8. Once all corners are secure under the display housing, adjust the protective film, if necessary, so it is centered on the touch screen.

Removal

1. To remove the protective film, slide the protective film in one direction until the edge clears.
2. Lift up on the edge of the protective film so it does not slide between the touch screen and display housing when the protective film is slid back to the center.
3. Repeat until all edges are free and remove the protective film.

Disconnect UPS Battery



CAUTION - The UPS battery must be disconnected before you ship the Thor VM1, [Replace UPS Battery](#) (page 4-60) or [Replace Front Panel](#) (page 4-58).

Equipment Required

The following equipment is user-supplied:

- Torquing tool capable of measuring inch pounds
- #2 Phillips screwdriver bit

Disconnect Procedure

1. For convenience, the Thor VM1 can be removed from the Quick Mount Smart Dock, though it is not necessary.
2. If the Thor VM1 remains in the dock, disconnect the power cable from the dock.
3. Shutdown the Thor VM1.
4. Place the Thor VM1 face down on a stable surface.
5. Using a #2 Phillips bit loosen the M3 screws and then remove the tethered access panel with the SIM label. This panel is on the right hand side when the Thor VM1 is face down with the top away from the user.

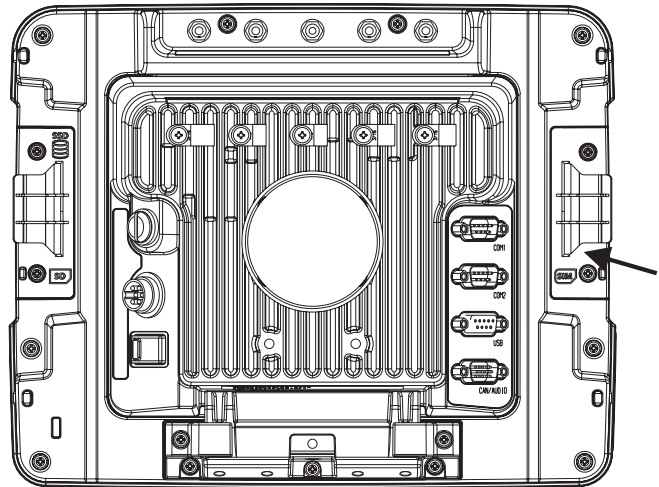

6. Locate the small push button located just below the SIM card installation slot..
7. Press the push button to disconnect the UPS. The UPS battery maintains its charge but is disconnected from the power circuitry of the Thor VM1.
8. Reattach the access panel, torquing the M3 screws to 4-5 inch pounds using a #2 Phillips bit.
9. When the Thor VM1 is attached to external power, the UPS battery is automatically reconnected.
10. Restart the Thor VM1.

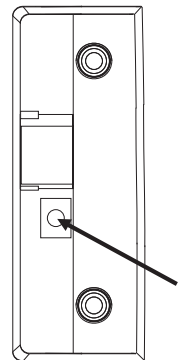

Install SD Card

An SD card slot is provided for storage expansion.

Equipment Required

The following equipment is user-supplied:

- Torquing tool capable of measuring inch pounds
- SD card - The following commercially available SD cards are recommended:
 - » Transcend® 2GB Industrial SD card (80X Speed) - **TS2GSD80I**
 - » ATP 4GB Industrial Grade SDHC card - **AF4GSDI**
- #2 Phillips screwdriver bit

Installation Procedure

1. For convenience, the Thor VM1 can be removed from the Quick Mount Smart Dock, though it is not necessary.
2. If the Thor VM1 remains in the dock, disconnect the power cable from the dock.
3. Shutdown the Thor VM1.
4. Place the Thor VM1 face down on a stable surface.
5. Using a #2 Phillips bit loosen the M3 screws and then remove the tethered access panel with the SIM label. This panel is on the right hand side when the Thor VM1 is face down with the top away from the user.

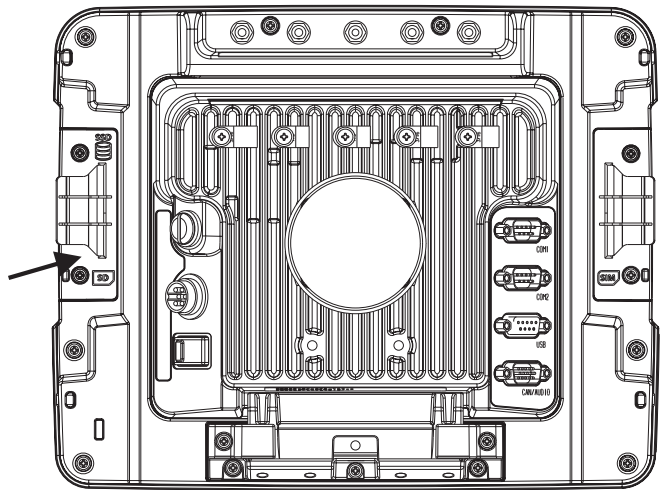

6. Locate the SD card installation slot.
7. Slide the SD card into the slot. The label side (front) of the SD card faces toward the back of the Thor VM1.
8. Reattach the access panel, torquing the screws to 4-5 inch pounds.
9. If removed, reinstall the Thor VM1 in the dock.
10. Restart the Thor VM1.
11. When using Windows explorer to view **My Computer**, the SD card is identified as **Removable Disk**, usually Drive D:.

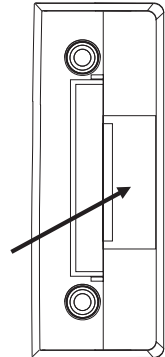

Install SIM Card

A SIM card may be required for WWAN.

Equipment Required

The following equipment is user-supplied:

- SIM card for desired carrier
- Torquing tool capable of measuring inch pounds
- #2 Phillips screwdriver bit

Installation Procedure

1. For convenience, the Thor VM1 can be removed from the Quick Mount Smart Dock, though it is not necessary.
2. If the Thor VM1 remains in the dock, disconnect the power cable from the dock.
3. Shutdown the Thor VM1.
4. Place the Thor VM1 face down on a stable surface.
5. Using a #2 Phillips bit loosen the M3 screws and then remove the tethered access panel with the SIM label. This panel is on the right hand side when the Thor VM1 is face down with the top away from the user.
6. Locate the SIM card installation slot.
7. Slide the SIM card into the slot.
8. Reattach the access panel, torquing the screws to 4-5 inch pounds.
9. If removed, reinstall the Thor VM1 in the dock.
10. Restart the Thor VM1.

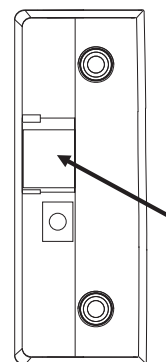
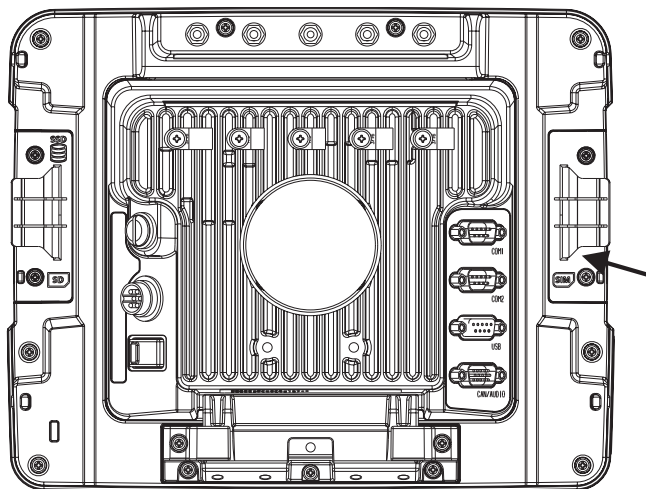

Replace Front Panel

Front Panel Options

The front panel of the Thor VM1 is field replaceable. The front panel assembly contains the keyboard, touch screen and optional defroster. Should any of these components fail, the front panel assembly can easily be replaced to reduce down-time. The replacement front panel is available in several configurations:

- 64-key ANSI keyboard with standard touch screen or cold storage touch screen
- 64-key 3270 keyboard with standard touch screen or cold storage touch screen
- 64-key 5250 keyboard with standard touch screen or cold storage touch screen

Equipment Required

The following equipment is user-supplied:

- Torquing tool capable of measuring inch pounds
- #2 Phillips screwdriver bit

Replacement Procedure



CAUTION - Before replacing the Thor VM1 front panel, [Disconnect UPS Battery](#) (page 4-55).

1. Place the Thor VM1 on a clean, well-lit surface before performing the front panel replacement.
2. Shutdown the Thor VM1.
3. Remove the Thor VM1 from the Quick Mount Smart Dock.
4. [Disconnect UPS Battery](#) (page 4-55).
5. Loosen the fourteen (14) captive M3 screws holding the front panel. Use a #2 Phillips bit.
6. Carefully lift the front panel away from the device

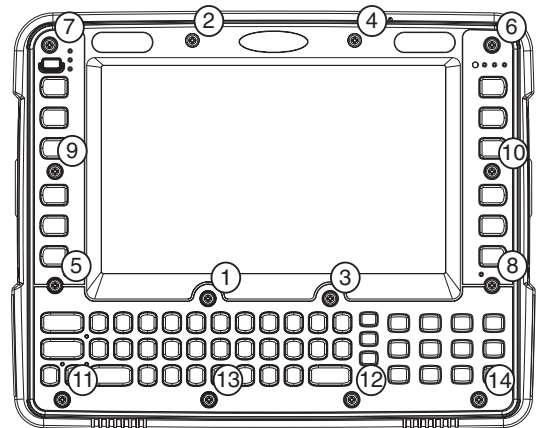

7. Carefully lift the front panel away from the device.

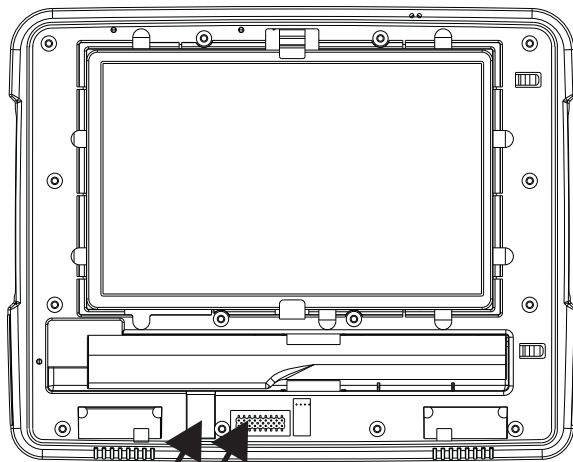

Slot on
Thor VM1 Wiring Connector
on Thor VM1

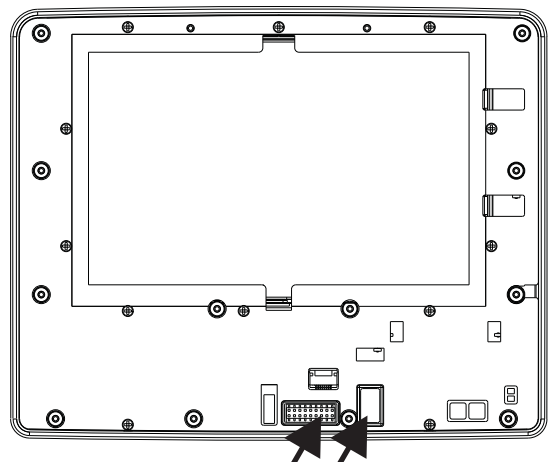

Slot on
Front Panel Wiring Connector
on Front Panel

-
8. Position the replacement front panel so the tab on the back of the front panel lines up with the slot on the Thor VM1. Be sure the two wiring connectors are also aligned.
 9. Position the replacement front panel so wiring connector on the back of the front panel lines up with the connector on the Thor VM1.
 10. Gently press the front panel into place.
 11. Tighten the fourteen (14) captive M3 screws. In the order shown in the top figure above, use a #2 Phillips bit and torque the screws to 6-7 inch pounds.
 12. Reinstall the Thor VM1 in the Quick Mount Smart Dock.
 13. When the Thor VM1 is placed in the powered dock, the UPS battery automatically reconnects.
 14. Restart the Thor VM1.
 15. When restarted, the Thor VM1 automatically recognizes the keyboard type (12 or 64 keys).
 16. If the defroster configuration has changed, use the Test button on the [Peripherals](#) (see page 5-86) control panel to update the Thor VM1 defroster configuration.

Replace UPS Battery

The UPS battery in the Thor VM1 is field replaceable. Should the UPS battery fail, it can easily be replaced to minimize downtime.

Equipment Required

The following equipment is user-supplied:

- Torquing tool capable of measuring inch pounds
- #2 Phillips screwdriver bit

Replacement Procedure



CAUTION - Before replacing the Thor VM1 UPS battery, [Disconnect UPS Battery](#) (page 4-55).

1. Place the Thor VM1 on a clean, well-lit surface before performing the front panel replacement.
2. Shutdown the Thor VM1.
3. Remove the Thor VM1 from the Quick Mount Smart Dock.
4. [Disconnect UPS Battery](#) (page 4-55).
5. Loosen the twelve (12) captive M3 screws holding the front panel. Use a #2 Phillips bit.
6. Carefully lift the front panel away from the device
7. Note the orientation of the UPS battery. Lift the UPS battery out of the battery well and place it outside the well. Do not pull on the wires attaching the battery to the Thor VM1 while lifting the battery.

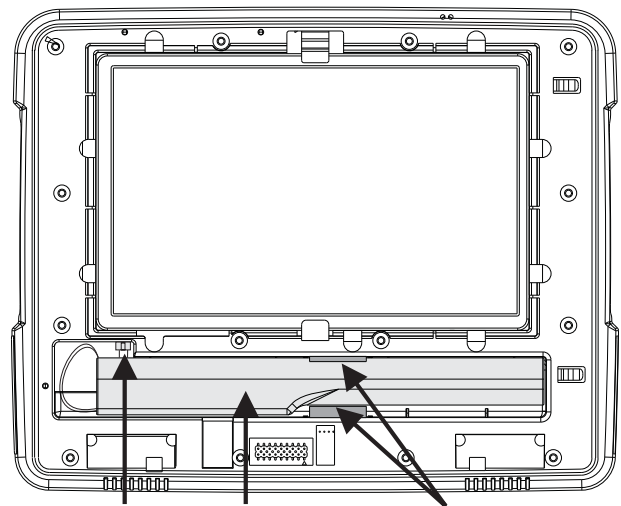
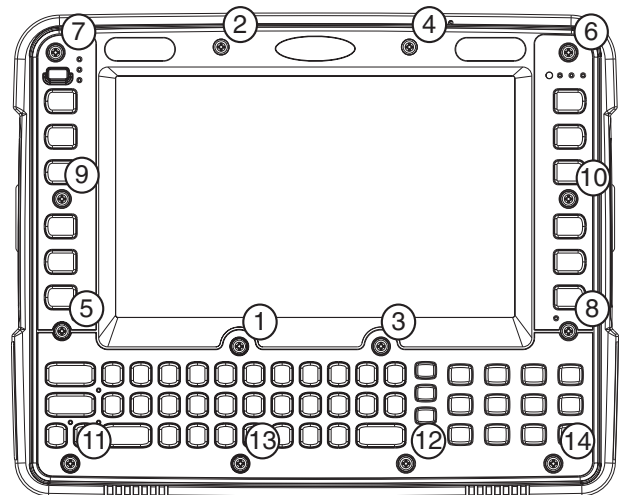

Wiring
Connector

UPS
Battery

Foam
Pads

8. Locate the retaining tab on the wiring connector for the UPS battery. Press on the tab and gently disconnect the UPS battery wiring from the Thor VM1.

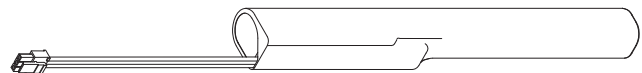

Wiring Connector
with Release Tab

9. Remove the old battery and set it aside.
10. Inspect the battery well to verify the two foam pads are still in place.
11. Align the wiring connector on the new UPS battery with the connector on the Thor VM1. Gently press the connector into place until the retaining tab snaps into place.
12. Place the UPS battery into the well. Note the orientation of the battery in the illustration below. The flat surface of the battery points toward the bottom of the Thor VM1. Make sure all wires are inside the battery well so they are not pinched when the front panel is reinstalled.

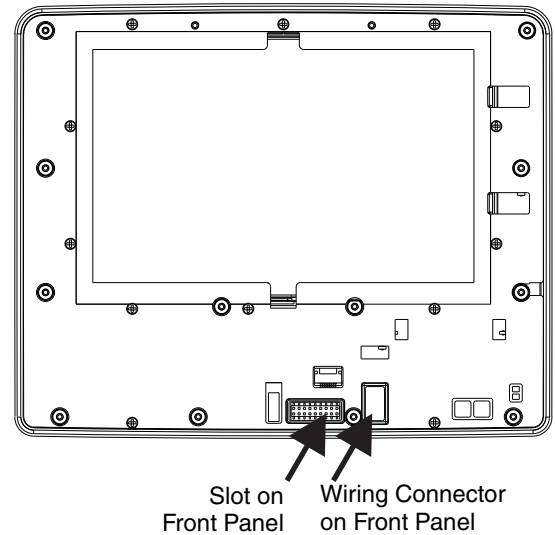
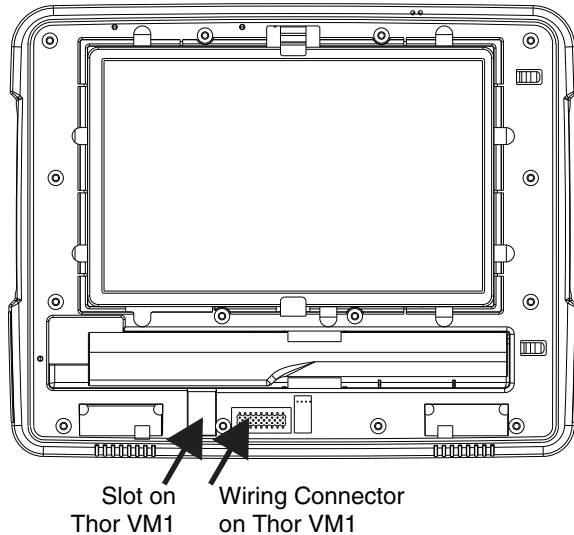

13. Position the front panel so the tab on the back of the front panel lines up with the slot on the Thor VM1. Be sure the two wiring connectors are also aligned.
14. Gently press the front panel into place.
15. Tighten the fourteen (14) captive M3 screws. In the order shown in the top figure above, use a #2 Phillips bit and torque the screws to 6-7 inch pounds.
16. Reinstall the Thor VM1 in the Quick Mount Smart Dock.
17. When the Thor VM1 is placed in the powered dock, the UPS battery automatically reconnects. The UPS battery automatically begins charging from the powered dock.
18. Restart the Thor VM1.



Microsoft Windows Setup and Configuration

After the system files are processed, Microsoft Windows begins to load. Windows maintains a System Registry and INI files. Standard Windows configuration options apply to the Thor VM1. Configuration options are located in the System Tray or the Control Panel:

- The System Tray contains icons for adjusting the time, date or volume level.
- The Control Panel contains icons for many other configuration options, such as Power Management, Regional and Language Options, etc.
- The Control Panel icons are also used to add, delete or modify software installed on the Thor VM1.

Drive C Folder Structure

Microsoft Windows is installed in the \Windows folder. In addition, Microsoft Windows creates other folders and several subfolders. For more information on the folder structure, please refer to commercially available Microsoft Windows OS reference guides.

Software Loaded on Drive C

The software loaded on the Thor VM1 computer consists of:

- BIOS
- Microsoft operating system (Windows Embedded Standard 2009)
- device drivers
- radio software, see [Summit Client Utility](#) (page 6-1)
- touch screen software
- keyboard wedge software, see [Freefloat Link*One Wedge](#) (page 5-2)

The software installed on the Thor VM1 is summarized below.

Note: Due to the complex folder structure and System Registry under Microsoft Windows, software should not be removed manually. Instead use the Add or Remove Programs Windows Control Panel:

Microsoft Windows

Microsoft Windows is installed in the \Windows subfolder, which is the Windows default. In addition, Windows places files in other folders and subfolders during installation. For more information, please refer to commercially available Microsoft Windows OS user guides.

Device Drivers

Device drivers are installed for all installed hardware options, such as the display, touch screen, radios, etc. For more information on Microsoft Windows device drivers, please refer to commercially available Windows OS reference guides.

Radio Software

The Thor VM1 is delivered with the radio software installed. Because the Thor VM1 uses a Microsoft Windows operating system, the radio installation includes Windows device drivers.

Touch Screen Software

PenMount Universal software is installed for calibrating the touch screen. See [Touch Screen Calibration](#) (page 5-26) for more information.

RFTerm

Start > All Programs > Honeywell RFTerm

Optional terminal emulation software. The application can also be accessed by double-clicking the RFTerm desktop icon.

Summit Client Utility

Start > Control Panel > Wi-Fi

Manage wireless clients installed in the Thor VM1.

Freefloat Link*One Wedge

Link*One bar code decoder configuration software is installed on the Thor VM1. A pdf User's Manual for Link*One is included as part of the installation at C:\Program Files\Freefloat\Freefloat Link One. Refer to this manual or the [Freefloat website](#) for information on configuring and using Link*One.

Freefloat Access*One TE (Optional)

Access*One terminal emulation software is available on the Thor VM1. A pdf User's Manual for Access*One is included as part of the installation at C:\Program Files\Freefloat\Freefloat Access One. Refer to this manual or the [Freefloat website](#) for information on configuring and using Access*One..

Control Panel

Most control panel applets on the Thor VM1 are standard Microsoft Windows items.

The control panels and other functions listed below may differ from a standard Microsoft Windows equipped PC or laptop.

About

Software

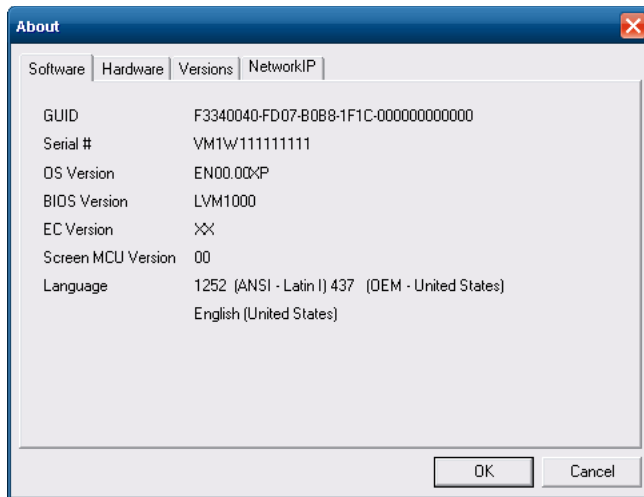

Firmware Versions

The Software tab lists the firmware versions installed. The BIOS, EC and Screen MCU firmware versions are shown on this tab.

Language

The Software tab displays the localized language version of the OS image. The language is identified as English or + an additional language.

The Thor VM1 may be pre-loaded with an English only OS. Contact [Technical Assistance](#) (page 9-1) for information on ordering a recovery DVD with an additional language.

Versions

The Versions tab displays the versions of many of the software programs installed. Not all installed software is included in this list and the list varies depending on the applications loaded on the Thor VM1. The Image line displays the revision of the system software installed. Refer to the last three digits to determine the revision level.

Versions Tab and the Registry

The Versions tab displays program version details from the registry.

Customized information can be displayed by modifying the Registry using the Registry Editor. Use caution when editing the Registry and make a backup copy of the registry before changes are made.

The registry settings for the Version tab are under HKEY_LOCAL_MACHINE \ Software \ LXE \ Version in the registry.

To add a user application to the Version panel, create a new string value under the HKLM\Software\LXE\Version key. The string name should be the Application name to appear in the Version window. The data for the value should be the version number to appear in the Version window.

Version strings can be equal to or less than 254 characters. Because the strings are displayed in a text box, any number can be accommodated, up to the 64K byte text box limitation.

Network IP

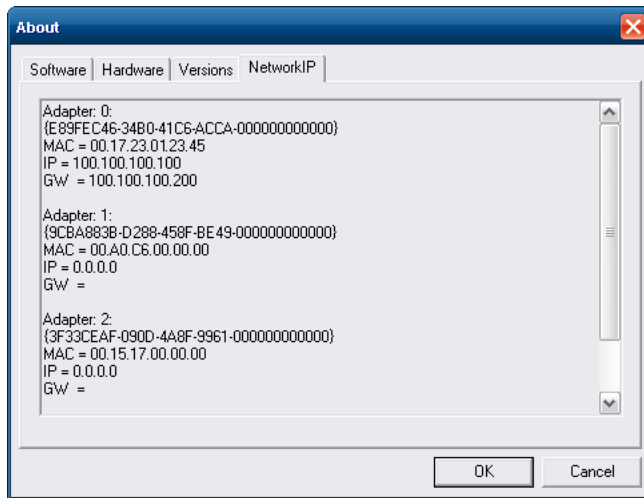

MAC Address

The Network IP tab displays the MAC address of the network card(s) such as the Summit WLAN radio and the Bluetooth module.

AutoOn

Start > Control Panel > AutoOn (Classic view)

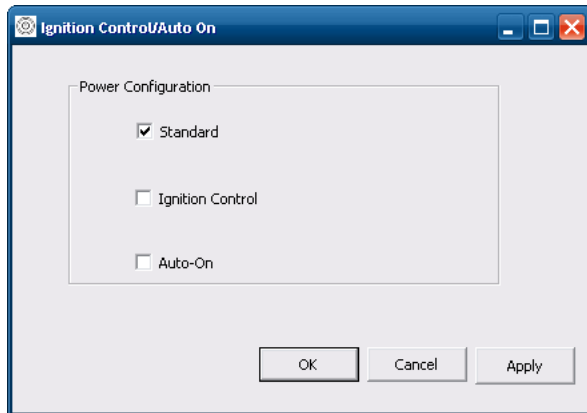

Select the desired Ignition Control / Auto On behavior.

Standard

The Thor VM1 is turned on and off manually by the user using the power button on the front of the device.

- The power switch on the Quick Mount Smart Dock must be On and the Thor VM1 connected to external power.
- In the absence of external power the Thor VM1 can operate from a sufficiently charged UPS battery.
- The Ignition Input wire, which is part of the DC Power Cable, is left disconnected.

When the Thor VM1 is on, the behavior of the power button press is configurable using the control panel.

Ignition Control

The Thor VM1 is turned on automatically when a signal is received via the Ignition Input wire, which is part of the DC Power Cable.

- The power switch on the Quick Mount Smart Dock must be On.
- The Ignition Input wire is connected to an appropriate source that provides a signal when vehicle ignition is turned on. Please see [Connect Power](#) (page 4-28) for cautions and wiring instructions.

When the vehicle ignition is turned off, this is treated the same as a power button press. The behavior of the power button press is configurable using the control panel.

Auto-On

The Thor VM1 automatically powers up when power is provided. This could be from switched vehicle power, the power switch on the Quick Mount Smart Dock being placed in the On position or external AC power being applied.

- The power switch on the Quick Mount Smart Dock must be On for external power to control the device.
- The Ignition Input wire, which is part of the DC Power Cable, is left disconnected.

No action occurs when the power source is disconnected.

Bluetooth

Start > Control Panel > Bluetooth

Discover and manage pairing with nearby Bluetooth devices.

Factory Default Settings

Discovered Devices	None
Settings	
Turn off Bluetooth	Disabled
Computer is connectable	Enabled
Computer is discoverable	Disabled
Prompt if devices request to pair	Enabled
Continuous search	Disabled
Filtered Mode	Enabled
Printed Port - COM7:	Disabled (unchecked) by default in both Filtered and Non Filtered Modes. The option is dimmed in Non Filtered Mode.
Logging	Disabled
Computer friendly name	System Computer Description
Reconnect	
Report when connection lost	Enabled
Report when reconnected	Disabled
Report failure to connect	Enabled
Clear Pairing Table on Boot	Disabled
Auto Reconnect on Boot	Enabled
Auto Reconnect	Enabled

Bluetooth taskbar Icon state and Bluetooth device Icon states change as Bluetooth devices are discovered, paired, connected and disconnected. There may be audible or visual signals as paired devices re-connect with the Thor VM1.

- The default Bluetooth setting is On.
- The Thor VM1 cannot be discovered by other Bluetooth devices when the **Computer is discoverable** option is disabled (unchecked) on the Settings panel.
- Other Bluetooth devices cannot be discovered if they have been set up to be Non-Discoverable or Invisible.
- When **Filtered Mode** is enabled, the Thor VM1 can pair with one Bluetooth scanner and one Bluetooth printer.
- When **Filtered Mode** is disabled, the Thor VM1 can pair with up to four Bluetooth devices.
- It is not necessary to disconnect a paired scanner and printer before a different scanner or printer is paired with the Thor VM1.
- The target Bluetooth device should be as close as possible (up to 32.8 ft (10 meters) Line of Sight) to the Thor VM1 during the pairing process.

Assumption: The System Administrator has Discovered and Paired targeted Bluetooth devices for the Thor VM1. The Thor VM1 operating system has been upgraded to the revision level required for Bluetooth client operation. An application (or API) is available that will accept data from serial Bluetooth devices.

Bluetooth Devices

The Bluetooth Devices tab displays any device previously discovered and paired with the Thor VM1.

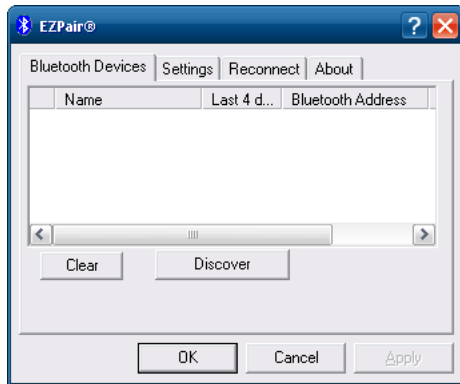

Discover

Tap the Discover button to locate all discoverable Bluetooth devices in the vicinity. The Discovery process also queries for the unique identifier of each device discovered.



Stop Button

Tap Stop at any time to end the Discover and Query for Unique Identifier functions.

Note: When an active paired device enters Suspend Mode, is turned Off or leaves the Thor VM1 Bluetooth scanning range, the Bluetooth connection between the paired device and the Thor VM1 is lost. There may be audible or visual signals as paired devices disconnect from the Thor VM1.

Bluetooth Device List

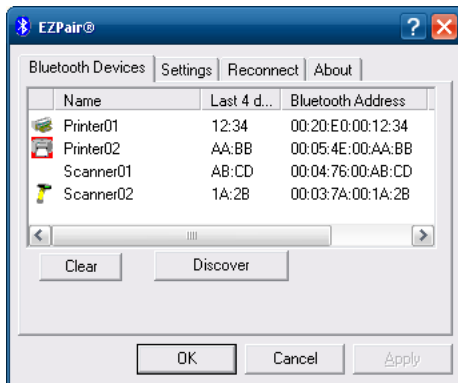

The discovered paired devices may or may not be identified with an icon. Discovered devices without an icon can be paired. The Bluetooth panel assigns an icon to the device name.

An icon with a red background indicates the device's Bluetooth connection is inactive.

An icon with a white background indicates the device is connected to the Thor VM1 and the device's Bluetooth connection is active.

Double-tap a device in the list to open the device properties menu. The target device does not need to be active.

Clear Button

Deletes all devices from the Device table that are not currently paired. A dialog box is presented, "Delete all disconnected devices?" Tap the **Yes** button to remove disconnected or deleted devices from the device table. The devices are removed from the Device table after closing and reopening the Bluetooth window. Tap the **No** button to make no changes.

Bluetooth Device Menu

Prerequisite: The Discover button has been clicked and there are Bluetooth devices listed.

Click on a device in the list to highlight it. Double-click the highlighted device to display the Bluetooth Device **right-click menu** as shown below. The Bluetooth device does not need to be active.

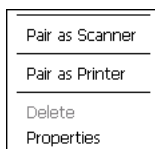

Right-Click Menu Options

Pair as Scanner	Receive data from the highlighted Bluetooth scanner or Bluetooth imager.
Pair as Printer	Send data to the highlighted Bluetooth printer.
Disconnect	Stop the connection between the Thor VM1 and the highlighted paired Bluetooth device.
Delete	Remove an unpaired device from the Bluetooth device list. The highlighted device name and identifier is removed from the Thor VM1 Bluetooth Devices panel after the user taps OK.
Properties	More information on the highlighted Bluetooth device.

Bluetooth Device Properties

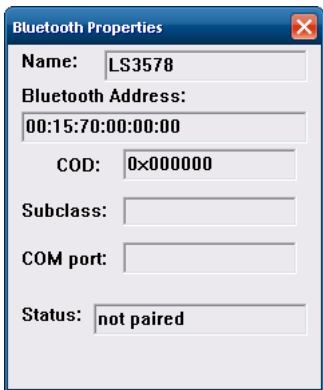

Data on the Bluetooth Properties panel cannot be changed by the user. The data displayed is the result of the device Query performed during the Discovery process.

The Status dialog box reflects the current state of the highlighted device.

Settings

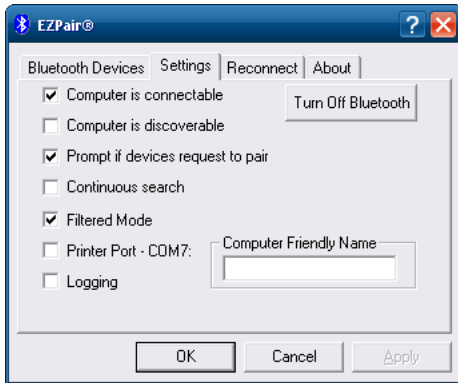

Note: These options can still be checked or unchecked whether Bluetooth connection is enabled or disabled.

Turn Off Bluetooth

Tap the button to toggle the Bluetooth client On or Off. The button title changes from *Turn Off Bluetooth* to *Turn On Bluetooth*.

Default

The default value is Bluetooth On.

Options

Option	Information
Computer is connectable	This option is Enabled by default. Disable this option to inhibit Thor VM1 connection initiated by a Bluetooth scanner.
Computer is discoverable	This option is Disabled by default. Enable this option to ensure other devices can discover the Thor VM1.

Option	Information
Prompt if devices request to pair	<p>This option is Enabled by default.</p> <p>A dialog box appears on the Thor VM1 screen notifying the user a Bluetooth device requests to pair with the Thor VM1.</p> <p>The requesting Bluetooth device does not need to have been Discovered by the Thor VM1 before the pairing request is received.</p> <p>Tap the Accept button or the Decline button to remove the dialog box from the screen.</p> <p>In some cases, if a Bluetooth device is already paired this setting cannot be changed. If this is the case, an error message is displayed and the option is not changed. The Bluetooth device must be disconnected before changing this setting.</p>
Continuous Search	<p>This option is Disabled by default.</p> <p>When enabled, the Bluetooth connection never stops searching for a device it has paired with when the connection is broken (such as the paired device entering Suspend mode, going out of range or being turned off). When disabled, after being enabled, the Thor VM1 stops searching after 30 minutes.</p>
Filtered Mode	<p>This option is Enabled by default.</p> <p>Determines whether the Bluetooth client discovers and displays all serial Bluetooth devices in the vicinity (Filtered Mode is disabled/unchecked) or the discovery result displays Bluetooth scanners and printers only (Filtered Mode is enabled/checked).</p> <p>When Filtered Mode is disabled, the Thor VM1 can pair with up to four Bluetooth devices.</p> <p>A Restart is required every time Filtered Mode is toggled on and off.</p> <p>When in non-filtered mode, the Thor VM1 supports SPP only.</p>
Printer Port - COM9	<p>This option is Disabled by default.</p> <p>This option assigns Bluetooth printer connection to COM9 instead of COM19. To enable this option, Filtered Mode must be enabled.</p>
Logging	<p>This option is Disabled by default.</p> <p>When logging is enabled, the Thor VM1 creates bt_log.txt and stores it in the C:/Program Files/LXE/Bluetooth folder. Bluetooth activity logging is added to the text file as activity progresses. A bt_log_bak.txt file contains the data stored by bt_log.txt prior to reboot.</p> <p>During a reboot process, the Thor VM1 renames bt_log.txt to bt_log_bak.txt. If a file already exists with that name, the existing file is deleted, the new bt_log_bak.txt file is added and a new bt_log.txt is created.</p>
Computer Friendly Name	<p>Default: Computer description (Control Panel > System > Computer Name tab).</p> <p>The name, or identifier, entered in this space by the System Administrator is used exclusively by Bluetooth devices and during Bluetooth communication.</p> <p>The Computer Description field is blank by default, so unless this field is modified before Bluetooth is installed, Computer Friendly Name is also blank, but can be edited by the user.</p>

Reconnect

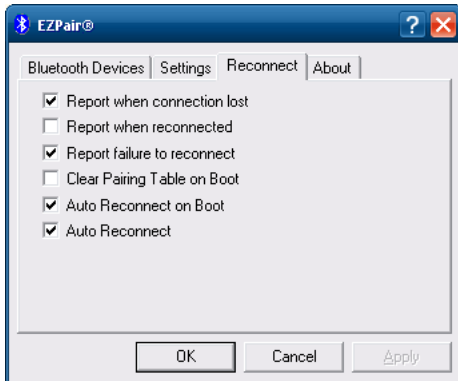

Note: These options can still be checked or unchecked whether Bluetooth connection is enabled or disabled.

Options

Option	Function
Report when connection lost	This option is Enabled (checked) by default. There may be an audio or visual signal when a connection between a paired, active device is lost. A visual signal may be a dialog box placed on the display notifying the user the connection between one (or all) of the paired Bluetooth devices has stopped. Tap the ok button to remove the dialog box from the screen.
Report when reconnected	This option is Disabled (unchecked) by default. There may be an audio or visual signal when a connection between a paired, active device is made. A visual signal may be a dialog box placed on the display notifying the user the connection between one (or all) of the paired Bluetooth devices has resumed. Tap the ok button to remove the dialog box from the screen.
Report failure to reconnect	This option is Enabled (checked) by default. The default time delay is 30 minutes. This value cannot be changed by the user. There may be an audio or visual signal when a connection between a paired, active device fails to re-connect. A visual signal may be a dialog box placed on the display notifying the user the connection between one (or all) of the previously paired Bluetooth devices has failed. Tap the X button or ok button to close the dialog box. Possible reasons for failure to reconnect: Timeout expired without reconnecting; attempted to pair with a device that is currently paired with another device; attempted to pair with a known device that moved out of range or was turned off; attempted to pair with a known device but the reason why reconnect failed is unknown.
Clear Pairing Table on Boot	This option is Disabled (unchecked) by default. When enabled (checked), all previous paired information is deleted upon any reboot sequence and no devices are reconnected. When enabled (checked) "Auto Reconnect on Boot" is automatically disabled (dimmed).
Auto Reconnect on Boot	This option is Enabled (checked) by default. All previously paired devices are reconnected upon any reboot sequence. When disabled (unchecked), no devices are reconnected upon any reboot sequence.

Option	Function
Auto Reconnect	<p>This option is Enabled (checked) by default. This option controls the overall mobile Bluetooth device reconnect behavior.</p> <p>When Auto Reconnect is disabled (unchecked), Auto Reconnect on Boot is automatically disabled and dimmed.</p> <p>When Auto Reconnect is disabled (unchecked), no devices are reconnected in any situation. The status of Auto Reconnect on Boot is ignored and no devices are reconnected on boot. The status of Clear Pairing Table on Boot controls whether the pairing table is populated on boot.</p> <p>When Auto Reconnect is enabled (checked) and Auto Reconnect on Boot is disabled (unchecked), devices are not reconnected on boot, but are reconnected in other situations (example: return from out-of-range).</p> <p>When Auto Reconnect is enabled (checked) and Clear Pairing Table on Boot is enabled (checked), devices are not reconnected on boot, but are reconnected in other situations (example: return from out-of-range). The pairing table is cleared on boot. The status of Auto Reconnect on Boot is ignored and the option is automatically disabled (unchecked) and dimmed.</p>

About

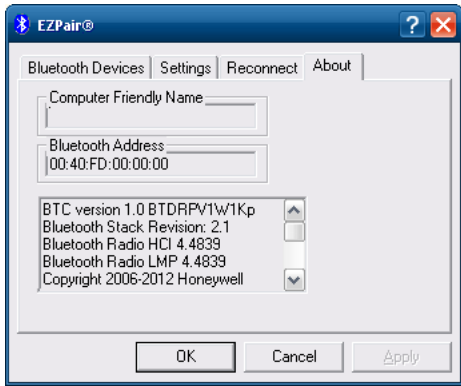

This panel lists the assigned Computer Friendly Name (that other devices may discover during their Discovery and Query process), the Bluetooth MAC address, and software version levels. The data cannot be edited by the user.

Using Bluetooth

Start > Control Panel > Bluetooth or Bluetooth icon in taskbar or Bluetooth icon on desktop



Tap the Bluetooth icon in the taskbar to open the Bluetooth EZPair application.

or



The Thor VM1 default Bluetooth setting is Enabled.

The Thor VM1 Bluetooth® module is designed to Discover and pair with nearby Bluetooth devices.

Prerequisite: The remote Bluetooth devices have been setup to allow them to be “Discovered” and “Connected/ Paired”. The System Administrator is familiar with the pairing function of the remote Bluetooth devices.

Bluetooth Devices Display - Before Discovering Devices

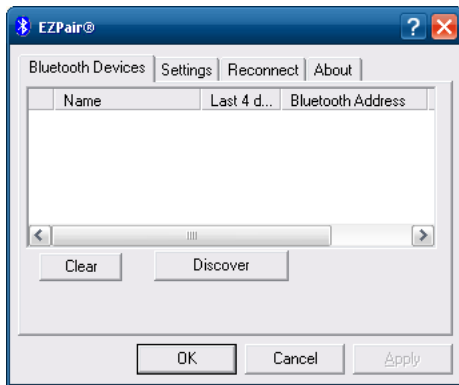

*Note: When **Filtered Mode** is enabled, only Bluetooth printers or Bluetooth scanners/imagers are recognized and displayed in the Bluetooth panel. All other Bluetooth devices are ignored.*

Initial Configuration

1. Select **Start > Control Panel > Bluetooth** or tap the Bluetooth icon in the taskbar or on the desktop.
2. Tap the **Settings** Tab.
3. Change the **Computer Friendly Name** at the bottom of the Settings display. The Bluetooth Thor VM1 default name is the Computer Description. Honeywell strongly urges assigning every Thor VM1 a unique name (up to 32 characters) before Bluetooth Discovery is initiated.
4. Check or uncheck the Thor VM1 Bluetooth options on the **Settings** tab.
5. Tap the **OK** button to save your changes or the **X** button to discard any changes.

Subsequent Use

Note: Taskbar and Bluetooth device Icon states change as Bluetooth devices are discovered, paired, connected and disconnected. A taskbar Bluetooth icon with a red background indicates Bluetooth is active and not paired with any device. A device icon with a red background indicates a disconnected paired device.



1. Tap the Bluetooth icon in the taskbar or on the desktop to open the Bluetooth EZPair application.
2. Tap the Bluetooth Devices tab.
3. Tap the Discover button. When the Bluetooth module begins searching for in-range Bluetooth devices, the button name changes to Stop. Tap the Stop button to cancel the Discover function at any time.
4. The discovered devices are listed in the Bluetooth Devices window.
5. Highlight a Bluetooth device in the Discovered window and double-tap to open the device properties menu.
6. Tap Pair as Scanner to set up the Thor VM1 to receive scanner data.

7. Tap Pair as Printer to set up the Thor VM1 to send data to the printer.
8. Tap Disconnect to stop pairing with the device. Once disconnected, tap Delete to remove the device name and data from the Thor VM1 Bluetooth Devices list. The device is deleted from the list after the OK button is clicked.
9. Upon successful pairing, the selected device may react to indicate a successful connection. The reaction may be an audio signal from the device, flashing LED on the device, or a dialog box is placed on the Thor VM1 display.
10. Whenever the Thor VM1 is turned On, all previously paired, live, Bluetooth devices in the vicinity are paired, one at a time, with the Thor VM1. If the devices cannot connect to the Thor VM1 before the re-connect time-out time period expires (default is approximately 20 seconds for each paired device) there is no indication of the continuing disconnect state if **Report Failure to Reconnect** is disabled.

Bluetooth Indicators

The Bluetooth taskbar Icon state changes as Bluetooth devices are discovered, paired, connected and disconnected.

There may be audible or visual signals as paired devices re-connect with the Thor VM1.

Taskbar Icon	Legend
	Thor VM1 is connected to one or more of the targeted Bluetooth device(s).
	Thor VM1 is not connected to any Bluetooth device. Thor VM1 is ready to connect with any Bluetooth device. Thor VM1 is out of range of all paired Bluetooth device(s). Connection is inactive.

Note: When an active paired device enters Suspend Mode, is turned Off or leaves the Thor VM1 Bluetooth scan range, the Bluetooth connection between the paired device and the Thor VM1 is lost. There may be audible or visual signals as paired devices disconnect from the Thor VM1.

Bluetooth LED	Legend
Blue, blinking slowly	Bluetooth is active but not connected to a device.
Blue, blinking medium	Bluetooth is paired and connected to a device.
Blue, blinking fast	Bluetooth is discovering other Bluetooth devices.
Off	Bluetooth hardware has been turned off or does not exist in the Thor VM1.

Bluetooth Bar Code Reader Setup

Please refer to the Bluetooth scanner manufacturer's User Guide; it may be available on the manufacturer's web site. Contact for Bluetooth product assistance.

Honeywell supports several different types of bar code readers. This section describes the interaction and setup for a mobile Bluetooth laser scanner or laser imager connected to the Thor VM1 using Bluetooth functions.

Prerequisites

- If the Thor VM1 has a Bluetooth address identifier bar code label affixed, then Bluetooth hardware and software is installed.
- The mobile Bluetooth laser scanner / laser imager battery is fully charged.
- The Thor VM1 is connected to AC or DC (vehicle) power.
- **Important:** The bar code numbering examples in this segment are not real and should not be created nor scanned with a Bluetooth scanner.
- To open the EZPair program, tap **Start > Control Panel > Bluetooth** or tap the Bluetooth icon on the desktop or tap the Bluetooth icon in the taskbar.

LnkB00440fd01020 - Sample



Locate the bar code label, similar to the one shown above, attached to the Thor VM1. The label is the Bluetooth address identifier for the Thor VM1.

The mobile Bluetooth scanner / imager requires this information before discovering, pairing, connecting or disconnecting can occur.

Important: The Thor VM1 Bluetooth address identifier label should remain protected from damage (rips, tears, spills, soiling, erasure, etc.) at all times. It may be required when pairing, connecting, and disconnecting new Bluetooth bar code readers.

Thor VM1 with Label

If the Thor VM1 has a Bluetooth address bar code label attached, follow these steps:

1. Scan the Bluetooth address bar code label, attached to the Thor VM1, with the Bluetooth mobile scanner.
2. If this is the first time the Bluetooth scanner has scanned the Thor VM1 Bluetooth label, the devices are paired. See section titled [Bluetooth Beep and LED Indications](#) (page 5-16). If the devices do not pair successfully, go to the next step.
3. Open the EZPair panel (**Start > Control Panel > Bluetooth**).
4. Tap Discover. Locate the Bluetooth scanner in the Discovery panel.
5. Double-tap the stylus on the Bluetooth scanner. The right-mouse-click menu appears.
6. Select Pair as Scanner to pair the Thor VM1 with the Bluetooth mobile scanner.

The devices are paired. The Bluetooth bar code reader responds with a series of beeps and an LED flashes. Refer to the following section titled [Bluetooth Beep and LED Indications](#) (page 5-16).

Note: After scanning the Thor VM1 Bluetooth label, if there is no beep and no LED flash from the Bluetooth device, the devices are currently paired.

Thor VM1 without Label

If the Thor VM1 Bluetooth address bar code label does not exist, follow these steps to create a unique Bluetooth address bar code for the Thor VM1:

First, locate the Thor VM1 Bluetooth address by tapping **Start > Control Panel > Bluetooth > About** tab.

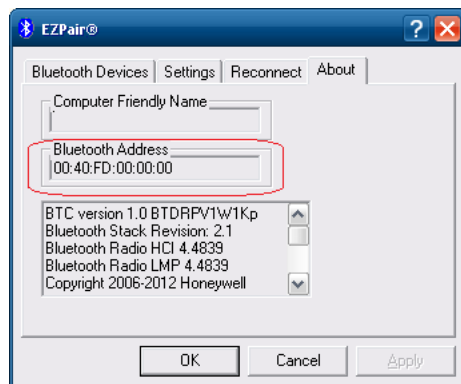

Next, create a Bluetooth address bar code label for the Thor VM1.

The format for the bar code label is as follows:

- Bar code type must be Code 128.
- FNC3 character followed by string Uppercase L, lowercase n, lowercase k, uppercase B and then the Bluetooth address (12 hex digits, no colons). For example, LnkB040fd002031.

Create and print the label.

Scan the Thor VM1 Bluetooth address bar code label with the Bluetooth bar code reader.

The devices are paired. The Bluetooth bar code reader responds with a series of beeps and LED flashes.

Note: After scanning the Thor VM1 Bluetooth label, if there is no beep and no LED flash from the Bluetooth bar code reader, the devices are currently paired.

See [Bluetooth Beep and LED Indications](#) (page 5-16).

Bluetooth Beep and LED Indications

Beep Type from Bluetooth Device	Behavior
Acknowledge label	1 beep
Label rejected	2 beeps at low frequency
Transmission error	Beep will sound high-low-high-low
Link successful	Beep will sound low-medium-high
Link unsuccessful	Beep will sound high-low-high-low

LED on Bluetooth Device	Behavior
Yellow LED blinks at 2 Hz	Linking in progress
Off	Disconnected or unlinked
Yellow LED blinks at 50 Hz	Bluetooth transmission in progress
Yellow LED blinks at the same rate as the paging beep (1 Hz)	Paging
Green LED blinks once a second	Disabled indication

Upon startup, if the Bluetooth device sounds a long tone, this means the Bluetooth device has not passed its automatic Selftest and has entered isolation mode. If the Bluetooth device is reset, the sequence is repeated. Contact [Technical Assistance](#) (page 9-1) for assistance.

Bluetooth Printer Setup

The Bluetooth managed device should be as close as possible, in direct line of sight, with the Thor VM1 during the pairing process.

1. Open the Bluetooth EZPair Panel.
2. Tap Discover. Locate the Bluetooth printer in the Discovery panel.
3. Tap and hold the stylus (or double-tap) on the Bluetooth printer ID until the right-mouse-click menu appears.

Select Pair as Printer to pair the Thor VM1 with the Bluetooth managed printer.

The devices are paired. The Bluetooth managed printer may respond with a series of beeps or LED flashes.

Please refer to the Bluetooth managed printer manufacturer's User Guide; it may be available on the manufacturer's web site. Contact [Technical Assistance](#) (page 9-1) for Bluetooth product assistance.

Note: If there is no beep or no LED flash from the Bluetooth managed printer, the Thor VM1 and the printer are currently paired.

Easy Pairing and Auto-Reconnect

The Bluetooth module can establish relationships with new devices after the user taps the Discover button. It can auto-reconnect to devices previously known but which have gone out of range and then returned within range (up to 32.8 ft (10 meters) Line of Sight).

Note: Configuration elements are persistent and stored in the registry.

Setup the Bluetooth module to establish how the user is notified by easy pairing and auto-reconnect events.

Display

Start > Control Panel > Display (Classic View)

Start > Control Panel > Appearance and Themes (Category View)

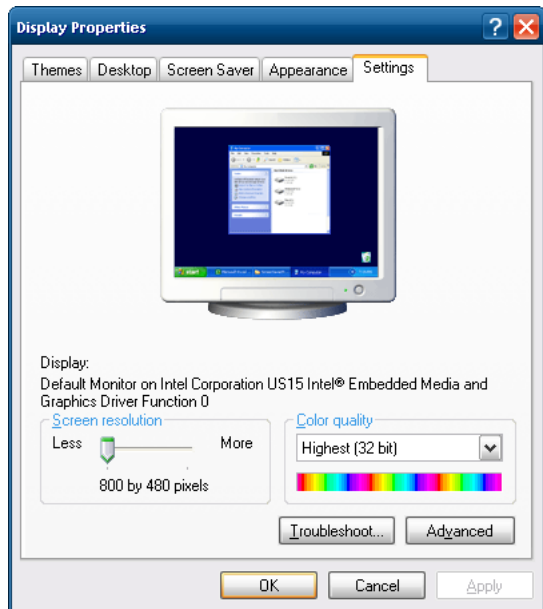

The Thor VM1 supports a 800x480 pixel display resolution.

[Screen Rotation](#) (page 5-24), [Screen Blanking](#) (page 5-23), [Defroster Control](#) (page 5-23) and [Automatic Brightness Control](#) (page 5-23) are configured on separate control panels.

Power Options

Select a Power Scheme

Power Schemes

Start > Control Panel > Power Options > Power Schemes tab (Classic View)

Start > Control Panel > Performance and Maintenance > Power Options > Power Schemes tab (Category View)

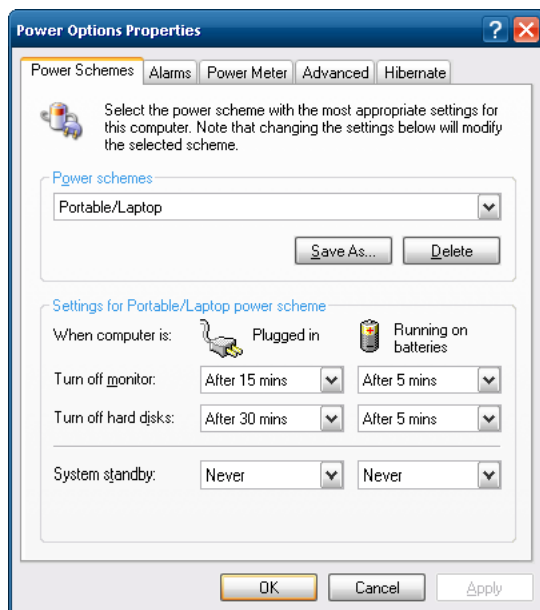

Power schemes can be configured for when the Thor VM1 is attached to an external power supply or when operating from the UPS battery.

View UPS Battery Status

Power Meter

Start > Control Panel > Power Options > Power Schemes tab (Classic View)

Start > Control Panel > Performance and Maintenance > Power Options > Power Schemes tab (Category View)

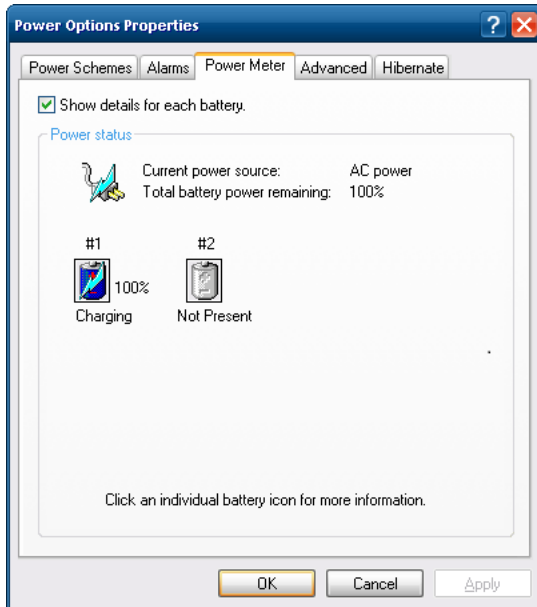

On the Power Meter tab, battery #1 refers to the UPS battery.

Shows power status: external power or UPS battery and the total battery power remaining before a recharge is necessary.

Configure Power Button Behavior

Start > Control Panel > Power Options > Power Schemes tab (Classic View)

Start > Control Panel > Performance and Maintenance > Power Options > Advanced tab (Category View)

Advanced

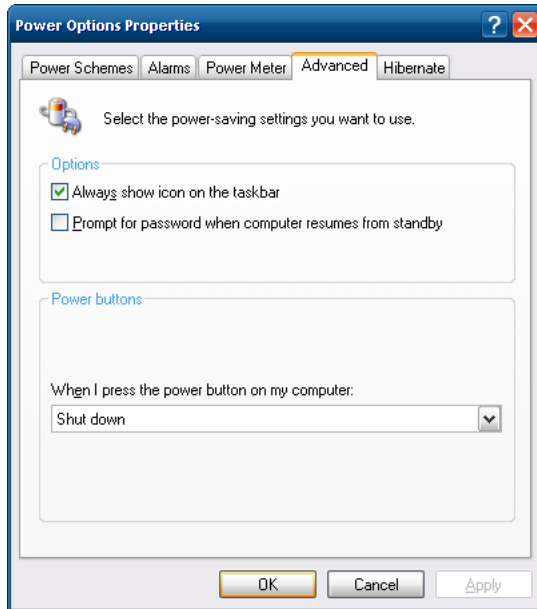

The **Advanced** panel allows setting the power button behavior when the unit is on and the power button is pressed. Options are:

- Do nothing
- Ask me what to do
- Stand by
- Shut down.

The default is to shut down. The Thor VM1 performs an orderly shut down when the power key is pressed when this option is enabled.

Hibernate

Enable Hibernation

Start > Control Panel > Power Options > Hibernate tab (Classic View)

Start > Control Panel > Performance and Maintenance > Power Options > Hibernate tab (Category View)

By default, hibernate is disabled on the Thor VM1. The default can be changed on this page.

The disk space necessary for hibernation plus the free disk space on the hard drive are listed.

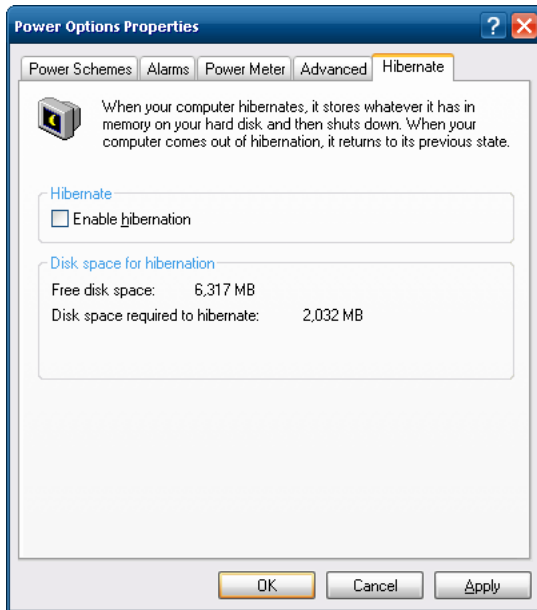

Screen Control

Start > Control Panel > Screen (Classic View)

Set screen properties for the Thor VM1.

Factory Default Settings

Screen Blanking (Blackout)	
Enable screen blanking	Enabled
Screen on delay (ms)	1000
COM Port	COM1
Automatic Brightness Control (for outdoor display only)	
Enable automatic brightness control	Disabled
Low to medium light level (%)	25
Medium to high light level (%)	75
Current Level	
LCD Brightness (%)	100 (see note)
Ambient Light (%)	(see note)
Defroster Control	
Enable defroster	Disabled
Trip point (°C)	40°C

Note: If automatic brightness control is enabled for an outdoor display, the value for LCD brightness depends on the Ambient Light %.

Note: There is no default value for Ambient Light % as it varies depending on the level of light where the Thor VM1 is located.

The screenshot shows a dialog box titled "Screen Control" with a close button (X) in the top right corner. The dialog is organized into several sections:

- Screen Blanking (Blackout):** Contains a checkbox for "Enable screen blanking" which is unchecked. Below it is a text box for "Screen on delay (ms)" containing the value "1000" and a dropdown menu for "COM PORT".
- Automatic Brightness Control (for outdoor display only):** Contains a checkbox for "Enable automatic brightness control" which is unchecked. Below it are two text boxes for "Low to medium light level (%)" and "Medium to high light level (%)", both of which are empty.
- Current Level:** Contains two text boxes: "LCD Brightness (%)" with the value "100" and "Ambient Light (%)" with the value "4".
- Defroster Control:** Contains a checked checkbox for "Enable defroster" and a text box for "Trip point (°C)" with the value "40".

At the bottom of the dialog are "OK" and "Cancel" buttons.

Screen Blanking

Screen blanking allows the Thor VM1 display to automatically be turned off whenever the vehicle is in motion.

Use the **Screen on delay** to specify the period of time in ms (milliseconds) between when the vehicle stops and the Thor VM1 screen turns on. For example, use the delay if the switch end of the cable is attached to the vehicle's accelerator pedal. Release of the accelerator may mean the truck is coasting to a stop rather than stationary. Configure the delay to allow time for the vehicle to coast to a stop. The default value is 1000 ms.

Specify the **COM Port** to which the screen blanking cable is attached. If a COM port is in use by another application, that COM port is grayed out and cannot be selected for screen blanking.



*Do not enable **Screen Blanking** until the cable is properly connected to the specified COM port.*

To disable screen blanking, uncheck the **Enable screen blanking** checkbox.

See [Screen Blanking](#) (page 4-44) for hardware requirements.

Refer to the wiring instructions, including appropriate cautions and warnings, in the [Connect Power](#) (page 4-28) section.

Automatic Brightness Control

When the Thor VM1 is equipped with an **outdoor display**, automatic brightness control can be enabled. When enabled, display brightness is based on ambient light detected by the ambient light sensor, located near the top right of the display. The default is disabled. To enable, check the **Enable automatic brightness control** checkbox and specify the thresholds for display backlight transition.

When enabled, the thresholds can be entered for display brightness transitions.

- When a low level of ambient light is detected, the display backlight is set to low level.
- When the ambient light exceeds the threshold specified in **Low to medium light level (%)**, the display backlight is automatically increased to a medium level.
- When the ambient light exceeds the threshold specified in **Medium to high light level (%)**, the display backlight is automatically increased to a high level.
- Likewise if the Thor VM1 is returned to a lower ambient light area, the display backlight automatically transitions to the appropriate lower display backlight level.

Current Level

Current levels of **LCD brightness** and **ambient light** are displayed as a percentage. Ambient light level is detected by the light sensor, located near the top right of the display.

Defroster Control

Enable the touch screen defroster, if installed, and set the trip point. Settings are ignored if the defroster is not installed.

If a defroster is installed, the defroster can be switched between the **Enabled** and **Disabled** states using the check box. The default is **Disabled** (unchecked).

Specify the Defroster trip point. The default trip point is 40°C/104°F.

Screen Rotation

Start > Control Panel > Screen Rotation (Classic view)



The Screen Rotation panel provides options for rotating the display:

0 Degree - Returns screen to the default orientation.

90 Degree - Rotates the screen counter clockwise 90 degrees as compared to the default orientation.

180 Degree - Rotates the screen 180 degrees as compared to the default orientation.

270 Degree - Rotates the screen counter clockwise 270 degrees as compared to the default orientation.

Select the desired rotation and tap **OK**. The screen may briefly go blank during the rotation process.

Tap **Close** to dismiss the panel and keep the current screen rotation.

Sounds

Start > Control Panel > Sounds and Audio Devices (Classic View)

Start > Control Panel > Sounds, Speech and Audio Devices (Category View)

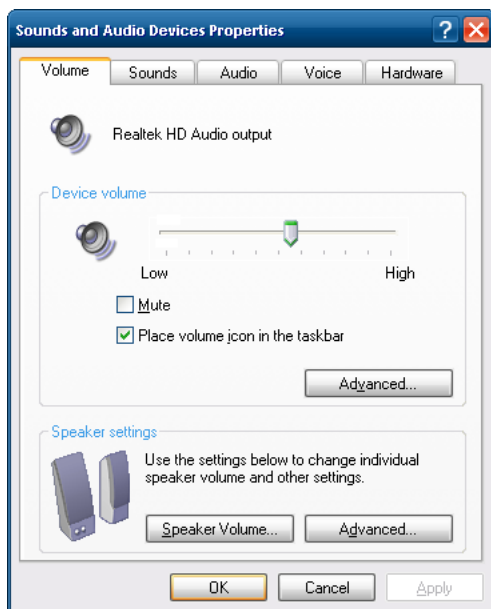

Use the slider bar to adjust the volume level as desired.

Alternatively:

- Tap the Volume icon, if present, in the taskbar and move the slider until the volume level is as desired.
- Use function keys - press the **2nd** key then **F9** to adjust volume up or **2nd** then **F10** to adjust volume down.

User Accounts

Note: The following applies to a Thor VM1 that is not part of a domain. When the Thor VM1 is part of a domain, the user is prompted for credentials at Windows startup or log on.

The Thor VM1 is pre-configured with an administrator account named Administrator. By default, the Thor VM1 automatically logs onto the Administrator account at Windows startup.

If the user assigns a password to the Administrator account:

- The password is stored and used when the Thor VM1 logs onto the Administrator account at Windows startup. The user is not prompted to enter a password.
- If the user logs off, the password must be manually entered to log back onto the Thor VM1.
- At the logon prompt, the user could specify a different user account (and password, if necessary) to log on, assuming the account has been added to the Thor VM1.
- When the Thor VM1 is restarted, the Administrator account automatically becomes the active user account, regardless of the active account before the restart.

If using the [Windows Certificate Store](#) (page 6-17) the user must assign a password to the active (Administrator) account.

Wi-Fi

Start > Control Panel > Wi-Fi (Classic view)

Provides a shortcut to access the 802.11a/b/g/n radio configuration utility.

Tap the Wi-Fi icon to access the [Summit Client Utility](#) (page 6-1).

Bar Code Readers

The Thor VM1 can use the following external bar code readers:

- Tethered hand-held scanners are tethered to a serial port or a USB host port (via a dongle cable) on the Thor VM1 Quick Mount Smart Dock and are configured by scanning the engine-specific bar codes in the scanner manufacturer's programming guide. The manufacturer's guides are usually shipped with the bar code reader.
- Wireless hand-held Bluetooth scanners are configured by scanning the engine-specific bar codes in the scanner manufacturer's programming guide. The manufacturer's guides are usually shipped with the bar code reader.
- The body worn Bluetooth Ring Scanner module may be using a Symbol 4400 Ring Imager or a Symbol 955 Ring Scanner. The BTRS module is configured by scanning the bar codes in the Bluetooth Ring Scanner Guide.

Scanner Wedge

Honeywell provides Freefloat Link*One for bar code decoding needs on the Thor VM1. Refer to the [Freefloat website](#) for documentation on Freefloat Link*One.

Touch Screen Calibration

Start > Programs > PenMount Windows Universal Driver

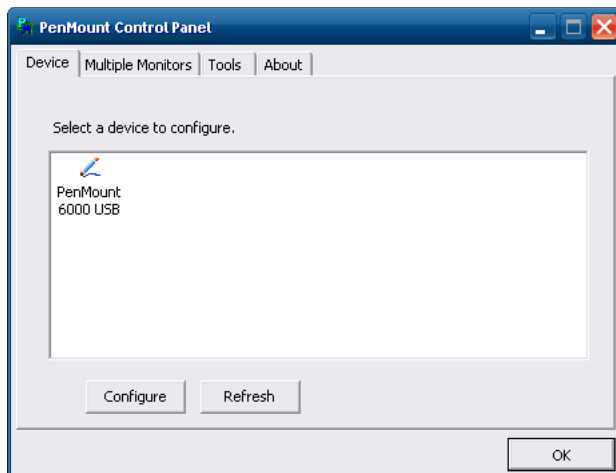

To calibrate the touch screen, tap **Start > Programs > PenMount Universal Driver > Utility > PenMount Control Panel**. Select **PenMount 6000 USB** and then tap **Configure**. Select Standard Calibration or Advance Calibration.

Advanced Calibration allows the user to select the number of calibration points. With either option, follow the on screen instructions to touch the red square, hold the touch and then lift the stylus to complete the calibration process.

BIOS

The Microsoft Windows operating system is installed before shipping. The default BIOS parameters are configured at that time. In most cases, it is unnecessary to modify the BIOS parameters.

Generally, it is only necessary to enter the BIOS setup to change the boot order of the drives.

This section is not intended to detail all features of the BIOS, instead it is intended to cover the most commonly used setup options.



CAUTION - Be very careful when using this utility to modify BIOS Setup parameters. The Thor VM1 may generate unexpected results when incorrect or conflicting parameter values are entered. Selecting incorrect or invalid options may require the Thor VM1 to be returned for repairs. The parameters should only be modified by Information Services personnel or the system administrator.

Accessing the BIOS Setup

When the Embedded BIOS screen (Phoenix Technologies) is displayed press the **Del** key to enter BIOS setup.

Use the arrow keys to move around the screen.

To access and modify the BIOS on the Thor VM1, an external keyboard must be attached.

Boot Order

To view or edit the boot order, select the **Boot** tab.

By default, the first device in the boot order is **USB Hard Drive**.

The second device is the **Windows CE Image**.



- If a USB drive, such as a thumb drive is attached to the Thor VM1, the device attempts to boot from the USB drive:
- If the USB drive contains a bootable sector, the Thor VM1 boots from the USB drive.
 - If the USB drive does not contain a bootable sector, the Thor VM1 does not boot. Remove the USB drive and boot the Thor VM1 again.

Exiting BIOS Setup

To exit the BIOS setup, select the **Exit** tab and select one of these options:

- Save Setting and Restart
- Exit Setup without Saving Changes
- Reload Factory-Defaults and Restart

Thor VM1 Recovery DVD

A recovery DVD is available to restore the operating system on your Thor VM1 to the same state it had when it was shipped from the factory. The recovery DVD may not reload all factory installed software. Recovery DVDs are available for English, Traditional Chinese, Simplified Chinese, Japanese, Korean, French, Spanish, German and Thai languages.

Contact [Technical Assistance](#) (page 9-1) for information on the recovery DVD and for assistance installing other factory loaded software..

Upgrading the Thor VM1

There may be firmware and BIOS upgrades available for the Thor VM1. Contact [Technical Assistance](#) (page 9-1) for upgrade information and instructions. In some cases, it may be necessary to upgrade firmware before upgrading the operating system.

Contact [Technical Assistance](#) (page 9-1) for upgraded firmware or operating system files. Follow the upgrade instructions provided by Technical Assistance.



The Thor VM1 must be connected to external power before upgrading the BIOS, firmware or operating systems. If the Thor VM1 is operating on UPS battery power, the upgrade process does not initiate and the Thor VM1 is not upgraded.

Automatic Firmware Update Utility

Windows Embedded Standard 7 and Windows 7 Professional only.

The automatic firmware update utility provides an automated process to update the firmware on the Thor VM1. Firmware that can be updated includes BIOS, EC (Embedded Controller) and Screen MCU (Micro Controller Unit). Firmware updates are distributed as cabinet (.cab) files. The .cab file contains the necessary firmware files (BIOS, EC and Screen MCU) and a utility to install firmware files. The firmware update utility is installed as part of the factory software load. This utility can be used to install newer firmware or to revert to older firmware.

It may be necessary to update firmware before installing an updated operating system.

Requirements

The automatic firmware update utility requires the hard drive (CompactFlash card) to have both C: and D: partitions. When the Thor VM1 is shipped with either a Windows 7 Professional or Windows Embedded Standard 7 operating system, these partitions are created during the manufacturing process.

The automatic firmware update utility is not supported for a Thor VM1 with a Windows Embedded Standard 2009 operating system.

Firmware Distribution Files

The following software files must be copied to drive D: in the order listed. The files can be copied to the D: drive manually or remotely. Contact [Technical Assistance](#) (see page 9-1) for upgrade files.

FWxxyyzz.cab - This file contains the firmware update files and a utility to verify version compatibility and install the firmware files. The file name is structured such that **xx** identifies the last digits of the BIOS firmware version, **yy** identifies the Embedded Controller firmware version and **zz** identifies the screen MCU version.

UpdateFW.tag - The file that triggers the update utility to begin. Be sure to copy this file only after all the .cab file has been copied. As soon as the Thor VM1 detects the presence of this file, the unit reboots in five seconds.

Update Process

1. Copy the files listed above to the D: drive. Copy the .cab file first then the .tag file.



Be sure to copy the updatefw.tag file to the D: drive last. The Thor VM1 begins the reboot process after detecting this file.

2. The Thor VM1 automatically reboots and starts the update process after detecting the updatefw.tag file. No user intervention is required to reboot the Thor VM1 or run the update utility after the reboot. The update utility operates in a DOS screen.
3. If the update is not successful, the update is tried three more times.
4. If the update fails, drive D: is cleaned up leaving flashapp.exe, a flashlog.txt and a retry.tag file.
5. Review the flashlog.txt file. The log file lists what firmware (if any) has been installed. If an error has occurred during the update process, it is detailed in the flashlog.txt file.

Configuration Cloning Utility (CCU)

Windows Embedded Standard 7 and Windows 7 Professional only.

This utility provides an automated process to read the configuration settings from one Thor VM1 and then apply those settings to one or more other Thor VM1s with the same operating system. The Configuration Cloning Utility (CCU) is installed as part of the factory software load. Configuration settings for the following items may be included:

- RFTerm
- EZ-Pair (Bluetooth)
- Honeywell Control Panels:
 - » Screen blanking
 - » USB powered in
 - » Enable/disable touch screen
 - » COM port pin 9 +5V or RI
 - » EWF and HORM (Windows Embedded Standard 7 only).

The CCU allows a configuration file (ccf file) to be created by:

- Reading the current program settings from the source Thor VM1
- Reading the default program settings from a ddf file.

If desired, settings can be modified (advanced user only) before saving the ccf file. If any changes have been made, the CCU can also apply them to the source Thor VM1.

The configuration file can then be copied and deployed to the destination Thor VM1(s). Options include:

- Import changes only - Only those configuration settings which have been modified from their default value are applied to the destination Thor VM1. All other settings on the destination Thor VM1 are left unchanged.
- Import changes and defaults - All configuration settings are applied to the destination Thor VM1. If a setting was modified on the source Thor VM1 the modified value is applied to the destination Thor VM1. Otherwise the default value is applied for that setting on the destination Thor VM1.

The Configuration Cloning Utility can be ran as a GUI or command line interface.



Before attempting to import settings from [RFTerm](#) (page 5-1), or [Bluetooth](#) (page 5-6) EZPair, open the program as an administrator and make any desired changes before importing. These programs do not write to the system registry until they have been opened as an administrator.

Configuration Cloning Utility GUI

To launch the Client Configuration Utility, locate the CCU icon either on the desktop or by selecting **Start > All Programs > Honeywell\Config Cloning** and right click on the icon. Select **Run as administrator** to launch the CCU.



It is necessary to run the CCU as an administrator because the CCU must be able to access and make changes to the Windows registry.

*Rather than selecting to run as administrator each time, right click on the CCU icon and select **Properties**. Tap the **Compatibility** tab and check **Run this program as an administrator**. This modification affects the current user only unless **Change settings for all users is tapped** before changing the privilege level.*

If a User Account Control message is displayed, you must allow the CCU to make changes to the computer.

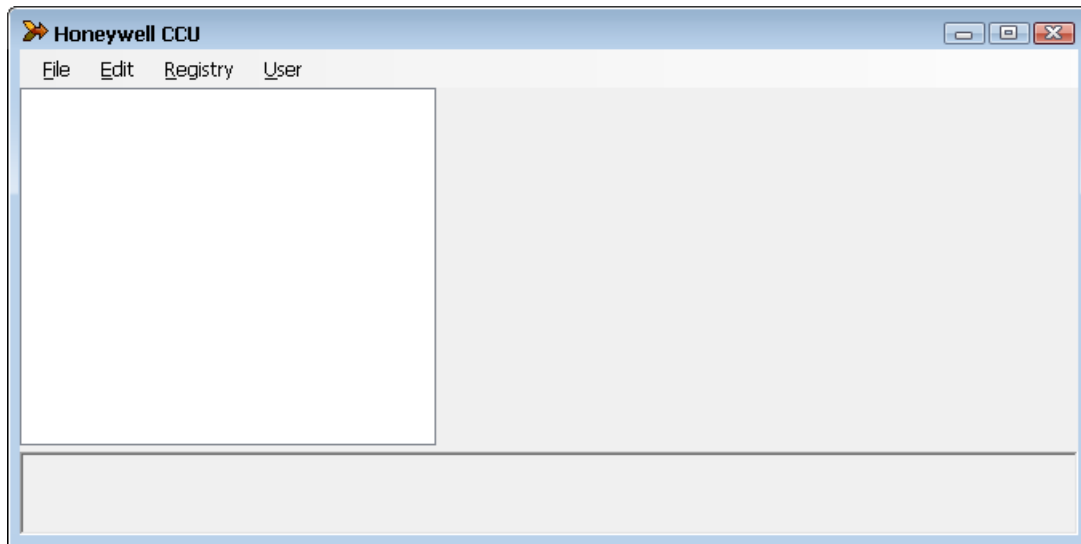

Menu Options

File

The File menu contains information for working with the configuration files.

About

Displays version and copyright information for the Configuration Cloning Utility.

Open

Opens a configuration file. The CCU looks for configuration files in the C:\Windows\DDF folder. CCU can open the following files types:

- ddf files - These files contain the factory default values for the software. These files are placed on the Thor VM1 when the applicable software was installed or upgraded. Use this option if you wish to start a configuration settings file based on the factory defaults.
- ccf files - These files contain the modified values for the software settings. These files are created with the CCU. ccf files are encrypted for security. Once a ccf file is created on one Thor VM1 it can be copied to other Thor VM1s to duplicate the configuration. An existing ccf file can be opened, modified, applied to the Thor VM1, saved, saved with a different name, etc.

Close

Closes the open data file.

Save

Saves the open data file as a ccf file.

- If a ccf file was opened, it is saved with the same name and in the same location.
- If a ddf file was opened, a prompt is displayed for the name to assign to the new ccf file. By default a new file is saved at C:\Windows\DDF though a different location can be specified.

Save As

Saves the open data file as a ccf. If a ccf file was opened, this option allows a new name or location for the data file to be specified during the save process.

Exit

Exits the CCU. A prompt may be displayed if there are unsaved ccf changes.

Edit

Provides access to the standard Windows Cut, Copy and Paste functions. These functions can be used to manipulate the settings within the configuration file.

Registry

Reads values from and writes values to the system registry.

Import Settings

Imports the current settings from the Windows registry for the selected application(s). When selected, the available programs from which settings can be read are displayed in a tree format.

Apply Settings

Applies the current settings to the Windows registry for the selected applications. During the process, a **Default all Non-Configured Parameters** prompt is displayed:

- Tap **Yes** to set all parameters not configured in the ccf file to defaults on the destination device.
- Tap **No** to apply the values from the ccf file and leave all other parameters as-is on the destination device.
- Tap **Cancel** to exit with no changes to the destination device.

Upon completion, exit the CCU and reboot the Thor VM1 so changes can take effect.

User

Selects the desired user access level:

-
- Basic - Basic users can open files and import setting from the system registry. Basic users cannot modify settings from an opened file or setting imported from the registry.. Basic users can apply setting to the system registry.
 - Advanced - Advanced users can open files and import settings registry. Advanced users can modify the values from either an opened file or imported from the system registry. Advanced users can apply settings to the system registry.

Shortcuts

The table below lists the valid shortcut key combinations within the CCU.

Shortcut key	Action
CTRL + A	Opens About screen
CTRL + O	Opens folder with CCF files (C:\Windows\DDF)
CTRL + C	Closes the open file (only valid when a ccf or ddf file
CTRL + S	Application is saved
CTRL + E	Application is closed
CTRL + X	Cuts the data
CTRL + C	Copies the selected data to the clipboard
CTRL + V	Pastes the data from the clipboard at the current location
CTRL + I	Displays import setting list
CTRL + L	Modified settings are applied
CTRL + B	Basic settings are displayed
CTRL + D	Advanced settings are displayed

Modifying Settings

Advanced user only. Basic user cannot view the expanded tree or modify settings.

When settings have been loaded (either from **Registry > Import Settings** or **File > Open**) the following screen is displayed.

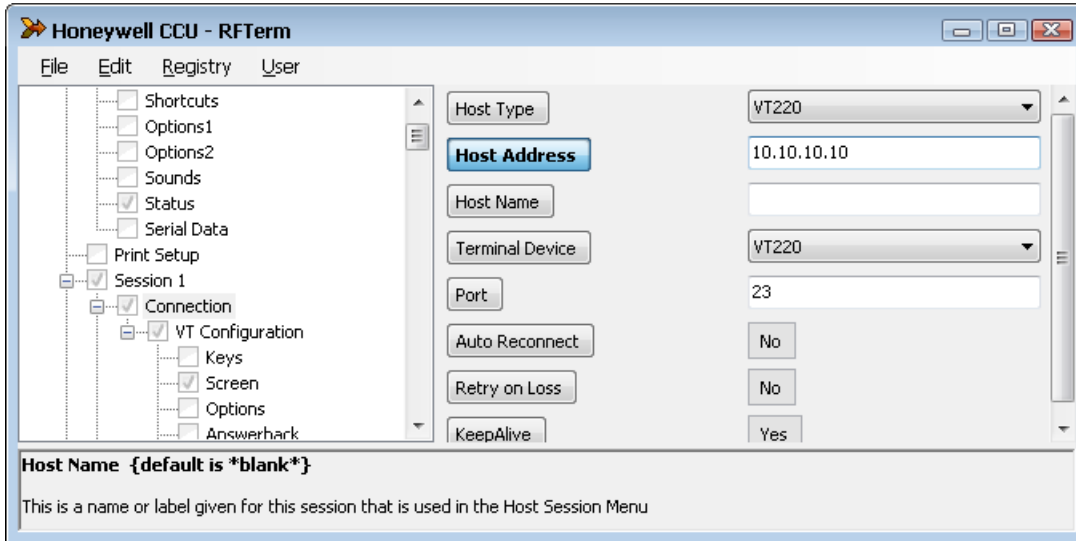

The left side of the upper pane displays the current program settings that have been imported or are part of the open ccf file. Click the + icon to expand the tree or the - icon to condense the tree. When the tree is expanded sufficiently to view the settings, the settings are displayed in the right portion of the upper pane. When a parameter is selected, the name of the parameter is highlighted in blue. The parameter name remains highlighted in blue (regardless of if the value was changed or not) until the parameter name button is tapped a second time. Enter a new value for the parameter as desired. Depending on the parameter selected, the following entry types are available:

- Text box - This is an open entry field and a new value can be typed into the text box. Depending on the parameter, there may be validity checking to ensure the entry in the text box is within the valid range.
- Pull-down list - A down arrow indicates the setting must be selected from a pull-down list of available values. Expand the list and select the desired setting from the list of options.
- Button - Items with two choices (such as Off or On) are displayed as a button. Tapping the button switches the value for the parameter.

When all desired parameter settings have been made, tap **File > Save** to save as a ccf file which can be used to deploy these settings on another Thor VM1.

If the parameter setting changes should also be applied to this Thor VM1, select **Registry > Import Settings**. After importing the settings, a reboot is necessary for the changes to take effect on the Thor VM1.



Do not attempt to modify programmable key settings within the CCU GUI. Instead, make all programmable key changes using the [Programmable Key](#) (page 5-41) control panel before importing the OS Control Panel into the CCU.

Using the CCU

Refer to the following examples for instructions on using the CCU.

Example 1: Import the current settings and save to a file

To import the current settings from the Thor VM1 running the CCU:

1. If you want to view the settings, tap **User** and select **Advanced**.
2. Tap **Registry > Import settings**.
3. Select the desired program(s) from which to import the settings.
4. Select **File > Save** then specify a file name and tap **Save** to save the settings to a ccf file.
5. The ccf file can be used to configure another Thor VM1. See Example 4.

Example 2: Modify settings on the current device and save to a file

To modify the settings on the Thor VM1 running the CCU:

1. Tap **User** and select **Advanced**.
2. Tap **Registry > Import settings**.
3. Select the desired program(s) from which to import the settings.
4. Make any desired changes to the settings.
5. Tap **Registry > Apply settings**
6. Select **File > Save** then specify a file name and tap **Save** to save the settings to a ccf file.
7. Reboot the Thor VM1 for the new settings to take effect.
8. The ccf file can be used to configure another Thor VM1. See Example 4.

Example 3: Reset a device to system defaults

To import and apply the default values to the Thor VM1 running the CCU:

1. If you want to view the default settings before applying, **User** and select **Advanced**.
2. Tap **File > Open** and change the file type to **ddf files (*.ddf)**.
3. Select the desired ddf file(s) for the software program(s) to return to default values.
4. Tap **File > Save** and specify a file name for the ccf file.
5. Tap **Registry > Apply settings**
6. Reboot the Thor VM1 for the new settings to take effect.
7. The ccf file can be used to configure another Thor VM1. See Example 4.

Example 4: Clone settings to another device

1. Create a ccf file using any of the above examples.
2. Copy the ccf file to C:\Windows\DDF on the destination Thor VM1.

Note: Rather than using the CCU GUI, the command line can be used to apply the settings to the destination device.

3. Open the CCU on the destination device.
4. Tap **File > Open** and select the ccf file that was copied to the device.
5. Tap **Registry > Import**.
6. When prompted to **Default all Non-Configured Parameters:**
 - Tap **Yes** to set all parameters not configured in the ccf file to defaults on the destination device.

- Tap **No** to apply the values from the ccf file and leave all other parameters as-is on the destination device.
- Tap **Cancel** to exit with no changes to the destination device.

7. Reboot the Thor VM1 for the new settings to take effect.

Configuration Cloning Utility Command Line Interface

Note: The CCU GUI must be closed before launching the command line interface.

To launch the Client Configuration Utility from the command line, locate the Command Prompt selecting **Start > All Programs > Accessories** and right click on the **Command Prompt** icon. Select **Run as administrator**.



It is necessary to open the command window as an administrator because the CCU must be able to access and make changes to the Windows registry.

The command utility can be ran from the installed location (C:\Program Files\Honeywell\Configuration Cloning Utility) or in portable mode (such as from a USB drive). When running in portable mode copy the following files to the USB drive:

- Configuration Cloning Utility.exe (from installation directory)
- PrivateKeyLoaded.dll (from installation directory)
- ccf file(s) (from C:\Windows\DDF or other user-specified folder)

A batch file (.bat) can be created to run the CCU commands.

Refer to the examples below to use the command line.

Example 1: Launch GUI

```
CCU.exe
```

If ran with no parameters, the GUI CCU interface is opened.

Example 2: Import settings

```
CCU.exe -import -[programs] -C:\myfile.ccf
```

Use this command line example to import the current settings from the Thor VM1 running the CCU.

Where:

import directs the CCU to read the settings from the system registry.

[programs] is replaced by one or more of the following programs from which to import settings, separated by an asterisk (*):

- **RFTerm** - RFTerm terminal emulation settings
- **BTDRWIN7** - Bluetooth EZ Pair settings
- **ThorWin7** - certain Honeywell specific control panels settings
- ***.*** can be used to import settings from all available programs.

C:\myfile.ccf is the path and filename assigned to the file to settings read from the device. The file must have a .ccf extension. If a file name is specified without a path, the ccf file is saved to C:\Windows\DDF.

```
CCU.exe -import -*.* -C:\myfile.ccf
```

The example above imports settings from all available programs into a file named myfile.ccf.

```
CCU.exe -import -RFTerm -C:\myfile.ccf
```

The example above imports RFTerm settings into a file named myfile.ccf.

```
CCU.exe -import -BTDRWIN7*ThorWin7 -C:\myfile.ccf
```

The example above imports RFTerm and Honeywell control panel settings into a file named myfile.ccf.

Example 3: Apply settings

```
CCU.exe -apply -reset -e:\myfile.ccf
```

Use this command line example to read the settings from the specified ccf file and apply them to the Thor VM1 running the CCC.

Where:

apply directs the CCU to read the settings from the ccf file and apply them to the system registry.

reset is optional. When -reset is specified, all settings are reset to their default values before the customized settings in the ccf file are applied. Any prior changes made to these settings on the Thor VM1 are lost. If -reset is not specified, only the changed values in the ccf file are applied. Any other settings previously made on the Thor VM1 are retained.

E:\myfile.ccf is the path and filename of the ccf file containing the changes to be applied. If the path is not specified, the ccf file must be located at C:\Windows\DDF.

Note: After using the -apply parameter, the Thor VM1 must be rebooted for the changes to take effect.

```
CCU.exe -apply -e:\myfile.ccf
```

The example above applies the settings from the ccf file to the device leaving all other settings untouched.

```
CCU.exe -apply -reset -e:\myfile.ccf
```

The example above resets all values to defaults then applies the settings to the device.



Wireless Network Connections

Network Connections Control Panel

For best results, do not use the Network Connections panel (**Start > Control Panel > Network Connections**) to disable the Summit wireless adapter. Due to a limitation of the system architecture, if the Summit wireless adapter is disabled in the Network Connections panel, it cannot be re-enabled from this control panel. Instead, the Thor VM1 must be rebooted to enable the Summit wireless adapter.

The Device Manager (**Control Panel > System > Hardware > Device Manager**) can be used to disable and enable the Summit wireless adapter without rebooting the Thor VM1.

Summit Wireless Network Configuration

The Summit client device is a Summit 802.11a/b/g/n radio, capable of 802.11a, 802.11b, 802.11g and 802.11n data rates. The radio can be configured for no encryption, WEP encryption or WPA security.

Security Options Supported are

Important Notes



It is important that all dates are correct on the Thor VM1 and host computers when using any type of certificate. Certificates are date sensitive and if the date is not correct authentication will fail.



It may be necessary to upgrade radio software in order to use certain Summit Client Utility (SCU) features. Contact [Technical Assistance](#) (page 9-1) for details.



When using the 802.11a radio, the U-NII 1 band is the preferred band for indoor operation. For regulatory domains in which the U-NII 3 band is allowed, the following channels are supported: 149, 153, 157 and 161. The AP must be configured accordingly.

After making any changes to the wireless configuration, restart the Thor VM1.

Summit Client Utility

Note: When making changes to profile or global parameters, the device should be restarted afterwards.

Start > All Programs > Summit > Summit Client Utility or

SCU Icon on Desktop or

Summit Tray Icon (if present) or

Wi-Fi Icon in the Windows Control Panel (if present)

The **Main** tab provides information, admin login and active profile selection.

Profile specific parameters are found on the **Profile** tab. The parameters on this tab can be set to unique values for each profile.

The **Status** tab contains information on the current connection.

The **Diags** tab provides utilities to troubleshoot the radio.

Global parameters are found on the **Global** tab. The values for these parameters apply to all profiles.

Summit Tray Icon

The Summit tray icon is not shown when the Thor VM1 is running Windows Embedded Standard 2009.

The Windows Wireless icon (located in the taskbar) may not display a successful wireless connection. The SCU Main tab should be used to verify the success of the connection instead.

Wireless Zero Config Utility



- The WZC utility has an icon in the toolbar indicating the Wireless Zero Config application is enabled but the connection is inactive at this time (the device is not connected to a network). The WZC icon may not be visible until control is passed to the WZC utility as described below.
- You can use either the Wireless Zero Configuration Utility or the Summit Client Utility to connect to your network. The Summit Client Utility is recommended because the Wireless Zero Configuration Utility cannot control the complete set of security features of the radio.

To Switch Control to the Wireless Zero Config Utility

1. Select **ThirdPartyConfig** in the Active Profile drop down box on the **Main** tab.
2. A message appears that a Power Cycle is required to make settings activate properly.
3. Tap **OK**.
4. Restart the Thor VM1.

The Summit Client Utility passes control to Wireless Zero Config and the WZC Wireless Information control panel. Using the options in the Wireless Zero Config panels, set up radio and security settings. There may be a slight delay before the Wireless Zero Config icon indicates the status of the connection.

To Switch Control to SCU

1. To switch back to SCU control, select any other profile except **ThirdPartyConfig** in the SCU Active Config drop down list on the **Main** tab.
2. A message appears that a Power Cycle is required to make settings activate properly.
3. Tap **OK**.
4. Restart the Thor VM1.

Radio control is passed to the SCU.

Main

Start > All Programs > Summit > Summit Client Utility > Main tab

Factory Default Settings

Admin Login	SUMMIT
Radio	Enabled
Active Config/Profile	Default
Regulatory Domain	FCC, ETSI or Worldwide

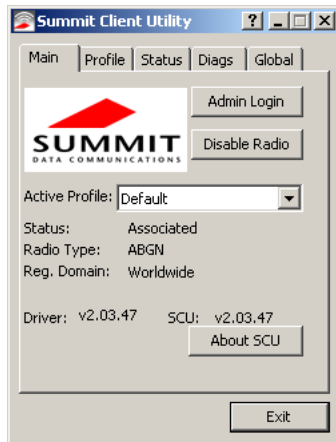

The Main tab displays information about the wireless client device including:

- SCU (Summit Client Utility) version
- Driver version
- Radio Type (ABGN is an 802.11 a/b/g/n radio).
- Regulatory Domain
- Copyright Information can be accessed by tapping the About SCU button
- Active Config profile / Active Profile name
- Status of the client (Down, Associated, Authenticated, etc.).

The **Active Profile** can be switched without logging in to Admin mode. Selecting a different profile from the drop down list does not require logging in to Administrator mode. The profile must already exist. Profiles can be created or edited after the Admin login password has been entered and accepted.

When the profile named “ThirdPartyConfig” is chosen as the active profile, the Summit Client Utility passes control to Wireless Manager for configuration of all client and security settings for the network module.

The **Disable Radio** button can be used to disable the network card. Once disabled, the button label changes to Enable Radio. By default the radio is enabled.

The **Admin Login** button provides access to editing wireless parameters. Profile and Global may only be edited after entering the Admin Login password.

The password is case-sensitive.

Once logged in, the button label changes to Admin Logout. To logout, either tap the **Admin Logout** button or exit the SCU without tapping the **Admin Logout** button.

Admin Login

To login to Administrator mode, tap the **Admin Login** button.

Once logged in, the button label changes to Admin Logout. The admin is automatically logged out when the SCU is exited. The Admin can either tap the **Admin Logout** button, or the **OK** button to logout.

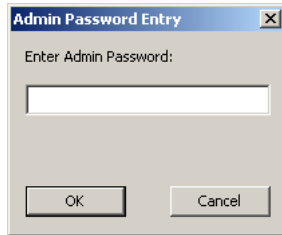

Enter the Admin password (the default password is SUMMIT and is case sensitive) and tap **OK**. If the password is incorrect, an error message is displayed.

The Administrator default password can be changed on the **tab**.

The end-user can:

- Turn the radio on or off on the **Main** tab.
- Select an active Profile on the **Main** tab.
- View the current parameter settings for the profiles on the **Profile** tab.
- View the global parameter settings on the **Global** tab.
- View the current connection details on the **Status** tab.
- View radio status, software versions and regulatory domain on the **Main** tab.
- Access additional troubleshooting features on the **Diags** tab.

After Admin Login, the end-user can also:

- Create, edit, rename and delete profiles on the **Profile** tab.
- Edit global parameters on the **Global** tab.
- Enable/disable the Summit tray icon in the taskbar.

Profile

Start > All Programs > Summit > Summit Client Utility > Profile tab

Note: Tap the Commit button to save changes before leaving this panel or the SCU. If the panel is exited before tapping the Commit button, changes are not saved!

Factory Default Settings

Profile	Default
SSID	Blank
Client Name	Blank
Power Save	CAM
Tx Power	Maximum
Bit Rate	Auto
Radio Mode	BGA rates full
Auth Type	Open
EAP Type	None
Encryption	None

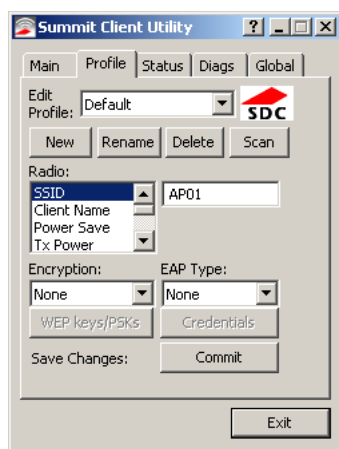

When logged in as an Admin use the Profile tab to manage profiles. When not logged in as an Admin, the parameters can be viewed, and cannot be changed. The buttons on this tab are dimmed if the user is not logged in as Admin. The Profile tab was previously labeled Config.

Buttons

Button	Function
Commit	Saves the profile settings made on this screen. Settings are saved in the profile.
Credentials	Allows entry of a username and password, certificate names, and other information required to authenticate with the access point. The information required depends on the EAP type.
Delete	Deletes the profile. The current active profile cannot be deleted and an error message is displayed if a delete is attempted.
New	Creates a new profile with the default settings (see Profile Parameters) and prompts for a unique name. If the name is not unique, an error message is displayed and the new profile is not created.
Rename	Assigns a new, unique name. If the new name is not unique, an error message is displayed and the profile is not renamed.

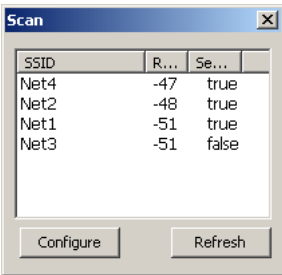
Button	Function
Scan	<p>Opens a window that lists access points that are broadcasting their SSIDs. Tap the Refresh button to view an updated list of APs. Each AP's SSID, its received signal strength indication (RSSI) and whether or not data encryption is in use (true or false). Sort the list by tapping on the column headers. If the scan finds more than one AP with the same SSID, the list displays the AP with the strongest RSSI and the least security.</p>  <p>If you are logged in as an Admin, tap an SSID in the list and tap the Configure button, you return to the Profile window to recreate a profile for that SSID, with the profile name being the same as the SSID (or the SSID with a suffix such as “_1” if a profile with the SSID as its name exists already).</p>
WEP Keys / PSK Keys	Allows entry of WEP keys or pass phrase as required by the type of encryption.

Note: Unsaved Changes – The SCU will display a reminder if the Commit button is not clicked before an attempt is made to close or browse away from this tab.

Important – The settings for Auth Type, EAP Type and Encryption depend on the security type chosen.

Profile Parameters

Parameter	Default	Explanation
Edit Profile	Default	A string of 1 to 32 alphanumeric characters, establishes the name of the Profile. Options are Default or ThirdPartyConfig.
SSID	Blank	A string of up to 32 alphanumeric characters. Establishes the Service Set Identifier (SSID) of the WLAN to which the client connects.
Client Name	Blank	A string of up to 16 characters. The client name is assigned to the network card and the device using the network card. The client name may be passed to networking wireless devices, e.g. Access Points.
Power Save	CAM	Power save mode. Options are: Constantly Awake Mode (CAM) power save off, Maximum (power saving mode) and Fast (power saving mode). When using power management, use FAST for best throughput results.
Tx Power	Maximum	Maximum setting regulates Tx power to the Max power setting for the current regulatory domain. Options are: Maximum, 50mW, 30mW, 20mW, 10mW, 5mW, or 1mW.
Bit Rate	Auto	Setting the rate to Auto will allow the Access Point to automatically negotiate the bit rate with the client device. Options are: Auto, 1 Mbit, 2, 5.5, 6, 9, 11, 12, 18, 24, 36, 48 or 54 Mbit.
Auth Type	Open	802.11 authentication type used when associating with the Access Point. Options are: Open, LEAP, or Shared key.
EAP Type	None	Extensible Authentication Protocol (EAP) type used for 802.1x authentication to the Access Point. Options are: None, LEAP, EAP-FAST, PEAP-MSCHAP, PEAP-GTC, PEAP-TLS, EAP-TTLS, or EAP-TLS. EAP Type chosen determines whether the Credentials button is active and also determines the available entries in the Credentials pop-up window.

Parameter	Default	Explanation
Encryption	None	Type of encryption to be used to protect transmitted data. Available options may vary by SCU version. Options are: None, WEP (or Manual WEP), WEP EAP (or Auto WEP), WPA PSK, WPA TKIP, WPA CCKM, WPA2 PSK, WPA2 AES, or WPA2 CCKM. CKIP is not supported in the Thor VM1. <i>Note: The Encryption type chosen determines if the WEP Keys / PSK Keys button is active and also determines the available entries in the WEP or PSK pop-up window.</i>
Radio Mode	BGA Rates Full	Specify 802.11a, 802.11b and/or 802.11g rates when communicating with the AP. The options displayed for this parameter depend on the type of radio installed in the mobile device. Options: B rates only (1, 2, 5.5 and 11 Mbps) BG Rates Full (All B and G rates) G rates only (6, 9, 12, 18, 24, 36, 48 and 54 Mbps) BG optimized or BG subset (1, 2, 5.5, 6, 11, 24, 36 and 54 Mbps) A rates only (6, 9, 12, 18, 24, 36, 48 and 54 Mbps) ABG Rates Full (All A rates and all B and G rates with A rates preferred) BGA Rates Full (All B and G rates and all A rates with B and G rates preferred) Ad Hoc (when connecting to another client device instead of an AP) Default: BGA Rates Full

It is important the **Radio Mode** parameter correspond to the AP to which the device is to connect. For example, if this parameter is set to G rates only, the Thor VM1 may only connect to APs set for G rates and not those set for B and G rates.

Status

Start > All Programs > Summit > Summit Client Utility > Status tab

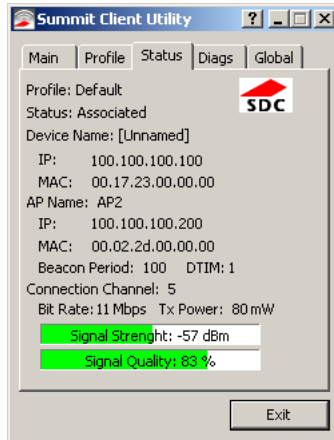

This screen provides information on the radio:

- The profile being used.
- The status of the radio card (down, associated, authenticated, etc.).
- Client information including device name, IP address and MAC address.
- Information about the Access Point (AP) maintaining the connection to the network including AP name, IP address and MAC address.
- Channel currently being used for wireless traffic.
- Bit rate in Mbit.
- Current transmit power in mW.
- Beacon period – the time between AP beacons in kilomicroseconds. (one kilomicrosecond = 1,024 microseconds).
- DTIM interval – A multiple of the beacon period that specifies how often the beacon contains a delivery traffic indication message (DTIM). The DTIM tells power saving devices a packet is waiting for them. For example, if DTIM = 3, then every third beacon contains a DTIM.
- Signal strength (RSSI) displayed in dBm and graphically.
- Signal quality, a measure of the clarity of the signal displayed in percentage and graphically.

There are no user entries on this screen.

Note: After completing radio configuration, it is a good idea to review this screen to verify the radio has associated (no encryption, WEP) or authenticated (LEAP, any WPA), as indicated above.

Diags

Start > All Programs > Summit > Summit Client Utility > Diags tab

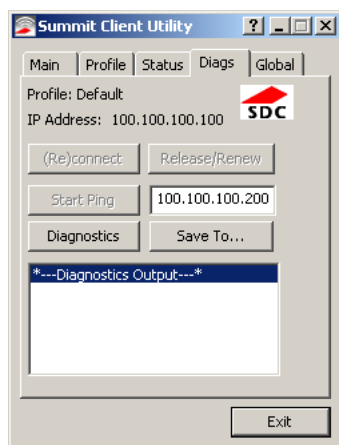

The Diags screen can be used for troubleshooting network traffic and radio connectivity issues.

- **(Re)connect** – Use this button to apply (or reapply) the current profile and attempt to associate or authenticate to the wireless LAN. All activity is logged in the Diagnostic Output box on the lower part of the screen.
- **Release/Renew** – Obtain a new IP address through release and renew. All activity is logged in the Diagnostic Output box. If a fixed IP address has been assigned to the radio, this is also noted in the Diagnostic Output box. Note that the current IP address is displayed above this button.
- **Start Ping** – Start a continuous ping to the IP address specified in the text box to the right of this button. Once the button is clicked, the ping begins and the button label changes to **Stop Ping**. Clicking the button ends the ping. The ping also ends when any other button on this screen is clicked or the user browses away from the Diags tab. The results of the ping are displayed in the Diagnostic Output box.
- **Diagnostics** – Also attempts to (re)connect to the wireless LAN. However, this option provides more data in the Diagnostic Output box than the (Re)connect option. This data dump includes radio state, profile settings, global settings, and a list of broadcast SSID APs.
- **Save To...** – Use this to save the results of the diagnostics to a text file. Use the explorer window to specify the name and location for the diagnostic file. The text file can viewed using an application such as WordPad.

Global

Start > All Programs > Summit > Summit Client Utility > Global tab

The parameters on this panel can only be changed when an with a password. The current values for the parameters can be viewed by the general user without requiring a password.

Note: Tap the Commit button to save changes. If the panel is exited before tapping the Commit button, changes are not saved!

Factory Default Settings

Roam Trigger	-65 dBm
Roam Delta	5 dBm
Roam Period	10 sec.
BG Channel Set	Full
DFS Channels	Off
DFS Scan Time	120 ms.
Ad Hoc Channel	1
Aggressive Scan	On
CCX Features	Optimized
WMM	On
Auth Server	Type 1
TTLS Inner Method	Auto-EAP
PMK Caching	Standard
WAPI	Off (dimmed)
TX Diversity	On
RX Diversity	On Start on Main
Frag Threshold	2346
RTS Threshold	2347
LED	Off
Tray Icon	On
Hide Passwords	On
Admin Password	SUMMIT (or blank)
Auth Timeout	8 seconds
Certs Path	C:\Program Files\Summit\certs
Ping Payload	32 bytes
Ping Timeout	5000 ms
Ping Delay ms	1000 ms
Logon Options	Use SCU credentials

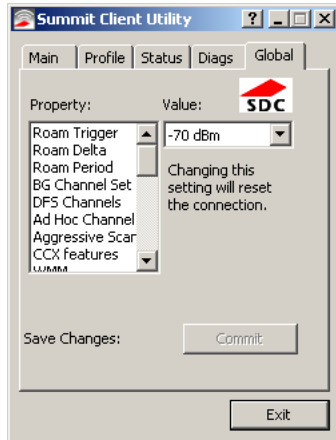

Custom Parameter Option

The parameter value is displayed as “Custom” when the operating system registry has been edited to set the Summit parameter to a value that is not available from the parameter’s drop down list. Selecting Custom from the drop down list has no effect. Selecting any other value from the drop down list will overwrite the “custom” value in the registry.

Global Parameters

Parameter	Default	Function
Roam Trigger	-65 dBm	If signal strength is less than this trigger value, the client looks for a different Access Point with a stronger signal. Options are: -50 dBm, -55, -60, -65, -70, -75, -80, -85, -90 dBm or .
Roam Delta	5 dBm	The amount by which a different Access Point signal strength must exceed the current Access Point signal strength before roaming to the different Access Point is attempted. Options are: 5 dBm, 10, 15, 20, 25, 30, 35 dBm or Custom.
Roam Period	10 sec.	The amount of time, after association or a roam scan with no roam, that the radio collects Received Signal Strength Indication (RSSI) scan data before a roaming decision is made. Options are: 5 sec, 10, 15, 20, 25, 30, 35, 40, 45, 50, 55, 60 seconds or Custom.
BG Channel Set	Full	Defines the 2.4GHz channels to be scanned for an AP when the radio is contemplating roaming. By specifying the channels to search, roaming time may be reduced over scanning all channels. Options are: Full (all channels) 1,6,11 (the most commonly used channels) 1,7,13 (for ETSI and TELEC radios only) or Custom.
DFS Channels	Off	Support for 5GHZ 802.11a channels where support for DFS is required. Options are: On, Off, Optimized. Not supported (always off) in some releases.
DFS Scan Time	120 ms.	ABG radio only. The amount of time the radio will passively scan each DFS channel to see if it will receive a beacon. Recommended value is 1.5 times that of the AP's beacon period.
Ad Hoc Channel	1	Use this parameter when the Radio Mode profile parameter is set to Ad Hoc. Specifies the channel to be used for an Ad Hoc connection to another client device. If a channel is selected that is not supported by the by the radio, the default value is used. Options are: 1 through 14 (the 2.4GHz channels) 36, 40, 44, 48 (the UNII-1 channels)

Parameter	Default	Function
Aggressive Scan	On	When set to On and the current connection to an AP weakens, the radio aggressively scans for available APs. Aggressive scanning works with standard scanning (set through Roam Trigger, Roam Delta and Roam Period). Aggressive scanning should be set to On unless there is significant co-channel interference due to overlapping APs on the same channel. Options are: On, Off
CCX or CCX Features	Optimized	Use of Cisco Compatible Extensions (CCX) radio management and AP specified maximum transmit power features. Options are: Full - Use Cisco IE and CCX version number, support all CCX features. The option known as "On" in previous versions. Optimized - Use Cisco IE and CCX version number, support all CCX features except AP assisted roaming, AP specified maximum transmit power and radio management. Off - Do not use Cisco IE and CCX version number. Cisco IE = Cisco Information Element.
WMM	On	Use of Wi-Fi Multimedia extensions. Devices running Windows XP can change the default value. Devices running all other OS cannot change the default value.
Auth Server	Type 1	Specifies the type of authentication server. Options are: Type 1 (ACS server) and Type 2 (non-ACS server)
TTLS Inner Method	Auto-EAP	Authentication method used within the secure tunnel created by EAP-TTLS. Options are: AUTO-EAP (Any available EAP method), MSCHAPV2, MSCHAP, PAP, CHAP, EAP-MSCHAPV2
PMK Caching	Standard	Type of Pairwise Master Key (PMK) caching to use when WPA2 is in use. PMK caching is designed to speed up roaming between APs by allowing the client and the AP to cache the results of 802.1X authentications, eliminating the need to communicate with the ACS server. Standard PMK is used when there are no controllers. The reauthentication information is cached on the original AP. The client and the AP use the cached information to perform the four-way handshake to exchange keys. Opportunistic PMK (OPMK) is used when there are controllers. The reauthentication information cached on the controllers. The client and the controller behind the AP use the cached information to perform the four-way handshake to exchange keys. If the selected PMK caching method is not supported by the network infrastructure, every roam requires full 802.11X authentication, including interaction with the ACS server. If the active profile is using WPA2 CCKM, the global PMK Caching setting is ignored and the client attempts to use CCKM. Options are: Standard, OPMK
WAPI	Off	Default is Off and dimmed (cannot be changed).
TX Diversity	On	How to handle antenna diversity when transmitting packets to the Access Point. Options are: Main only, and On.
RX Diversity	On Start on Main	How to handle antenna diversity when receiving packets from the Access Point. Option is: On-start on Main This parameter cannot be changed for some Summit radios.
Frag Thresh	2346	If the packet size (in bytes) exceeds the specified number of bytes set in the fragment threshold, the packet is fragmented (sent as several pieces instead of as one block). Use a low setting in areas where communication is poor or where there is a great deal of wireless interference. Options are: Any number between 256 bytes and 2346 bytes.

Parameter	Default	Function
RTS Thresh	2347	If the packet size exceeds the specified number of bytes set in the Request to Send (RTS) threshold, an RTS is sent before sending the packet. A low RTS threshold setting can be useful in areas where many client devices are associating with the Access Point. This parameter cannot be changed.
LED	Off	The LED on the wireless card is not visible to the user when the wireless card is installed in a sealed mobile device. Options are: On, Off.
Tray Icon	On	Determines if the Summit icon is displayed in the System tray. Options are: On, Off The tray icon is not displayed when the Thor VM1 is running a Windows Embedded Standard 2009 operating system.
Hide Password	On	When On, the Summit Config Utility masks passwords (characters on the screen are displayed as an *) as they are typed and when they are viewed. When Off, password characters are not masked. Options are: On, Off.
Admin Password	SUMMIT (or Blank)	A string of up to 64 alphanumeric characters that must be entered when the Admin Login button is tapped. If Hide Password is On, the password is masked when typed in the Admin Password Entry dialog box. The password is case sensitive. This value is masked when the Admin is logged out. Options are: none.
Auth Timeout	8 seconds	Specifies the number of seconds the Summit software waits for an EAP authentication request to succeed or fail. If the authentication credentials are stored in the active profile and the authentication times out, the association fails. No error message or prompting for corrected credentials is displayed. If the authentication credentials are not stored in the active profile and the authentication times out, the user is again prompted to enter the credentials. Options are: An integer from 3 to 60.
Certs Path	certificates	A valid directory path, of up to 64 characters, where WPA Certificate Authority and User Certificates are stored on the mobile device when not using the Windows certificates store. Ensure the Windows folder path exists before assigning the path in this parameter. See Certificates (page 6-32) for instructions on obtaining CA and User Certificates. This value is masked when the Admin is logged out. Options are: none. The complete path is C:\Program Files\Summit\certs
Ping Payload	32 bytes	Maximum amount of data to be transmitted on a ping. Options are: 32 bytes, 64, 128, 256, 512, or 1024 bytes.
Ping Timeout ms	5000	The amount of time, in milliseconds, that a device will be continuously pinged. The Stop Ping button can be tapped to end the ping process ahead of the ping timeout. Options are: Any number between 0 and 30000 ms.
Ping Delay ms	1000	The amount of time, in milliseconds, between each ping after a Start Ping button tap. Options are: Any number between 0 and 30000 ms.
Logon Options	SCU	Use SCU or Windows login credentials.

Note: Tap the Commit button to save changes. If this panel is closed before tapping the Commit button, changes are not saved!

Logon Options

There are two options available, a [Single Signon](#) (page 6-14) option which uses the Windows username and password as the credentials for 802.1x authentication and a [Pre-Logon Connection](#) (page 6-14) option which uses saved credentials for 802.1x authentication before Windows logon.

If either option is enabled, the credentials entered here take precedence over any credentials entered on the profile tab.

To use either option, select **Logon Options** from the **Property** list which activates the **Logon Options** button.

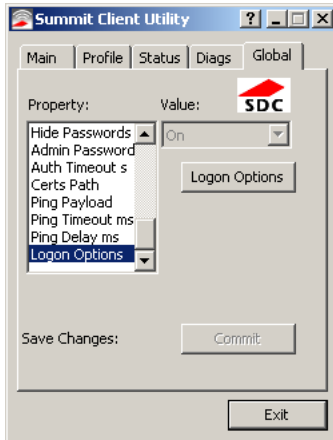

Click the **Logon Options** button.

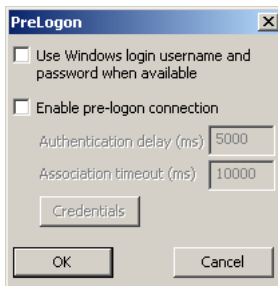

Single Signon

To use the Single Signon option, select the checkbox for **Use the Windows username and password when available**. When the active profile is using LEAP, PEAP-MSCHAP, PEAP-GTC or EAP-FAST, the SCU ignores the username and password, if any, saved in the profile. Instead, the username and password used for Windows logon is used. Any certificates needed for authentication must still be specified in the profile.

Click **OK** then click **Commit**.

Pre-Logon Connection

To use the Pre_logon connection, select the checkbox for Enable pre-logon connection. This option is designed to be used when:

- EAP authentication is required for a WLAN connection
- Single Signon is configured, so the Windows username and password are used as credentials for EAP authentication
- The WLAN connection needs to be established before the Windows login.

Once this option is enabled, the **Authentication delay** and **Association timeout** values can be adjusted as necessary. Both values are specified in milliseconds (ms).

The default authentication delay is 5000 ms and the valid range is 0 - 600,000 ms.

The default association timeout is 10,000 ms and the valid range is 10,000 to 600,000 ms.

Click on the **Credentials** button to enter the logon credentials.

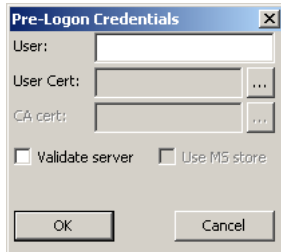

If using the Windows certificate store:

1. Check the **Use MS store** checkbox. The default is to use the Full Trusted Store.
2. To select an individual certificate, click on the **Browse** button.
3. Uncheck the **Use full trusted store** checkbox.
4. Select the desired certificate and click **Select**. You are returned to the Credentials screen.
5. Click **OK** then click **Commit**.

If using the Certs Path option:

1. Leave the Use MS store box unchecked.
2. Enter the certificate filename in the CA Cert text box.
3. Click **OK** then click **Commit**.

Sign-On vs. Stored Credentials

When using wireless security that requires a user name and password to be entered, the Summit Client Utility offers these choices:

- The Username and Password may be entered on the Credentials screen. If this method is selected, anyone using the device can access the network.
- The Username and Password are left blank on the Credentials screen. When the device attempts to connect to the network, a sign on screen is displayed. The user must enter the Username and Password at that time to authenticate.
- When using Summit with the Thor VM1, there is an option on the Global tab to use the Windows user name and password to log on instead of any username and password stored in the profile.

To Use Stored Credentials

1. After completing the other entries in the profile, click on the **Credentials** button.
2. Enter the Username and Password on the Credentials screen and click the **OK** button.
3. Click the **Commit** button.
4. For LEAP and WPA/LEAP, configuration is complete.
5. For PEAP-MSCHAP and PEAP-GTC, importing the CA certificate into the Windows certificate store is optional.
6. For EAP-TLS, import the CA certificate into the Windows certificate store. Also import the User Certificate into the Windows certificate store.
7. Access the Credentials screen again. Make sure the **Validate server** and **Use MS store** checkboxes are checked.
8. The default is to use the entire certificate store for the CA certificate. Alternatively, use the **Browse** button next to the CA Cert (CA Certificate Filename) on the Credentials screen to select an individual certificate.
9. For EAP-TLS, also enter the User Cert (User Certificate filename) on the credentials screen by using the **Browse** button.
10. If using EAP FAST and manual PAC provisioning, input the PAC filename and password..
11. Click the **OK** button then the **Commit** button.

-
12. If changes are made to the stored credentials, click **Commit** to save those changes before making any additional changes to the profile or global parameters.
 13. Verify the device is authenticated by reviewing the Status tab. When the device is properly configured, the Status tab indicates the device is Authenticated and the method used.

Note: See [Configuring the Profile](#) (page 6-18) for more details.

Note: If invalid credentials are entered into the stored credentials, the authentication will fail. No error message is displayed. The user may or may not be prompted to enter valid credentials.

To Use Sign On Screen

1. After completing the other entries in the profile, click on the **Credentials** button. Leave the Username and Password blank. No entries are necessary on the Credentials screen for LEAP or LEAP/WPA.
2. For PEAP-MSCHAP and PEAP-GTC, importing the CA certificate into the Windows certificate store is optional.
3. For EAP-TLS, import the CA certificate into the Windows certificate store. Also import the User Certificate into the Windows certificate store.
4. Access the Credentials screen again. Make sure the **Validate server** and **Use MS store** checkboxes are checked.
5. The default is to use the entire certificate store for the CA certificate. Alternatively, use the Browse button next to the CA Cert (CA Certificate Filename) on the Credentials screen to select an individual certificate.
6. For EAP-TLS, also enter the User Cert (User Certificate filename) on the credentials screen by using the **Browse** button.
7. Click the **OK** button then the **Commit** button.
8. When the device attempts to connect to the network, a sign-on screen is displayed.
9. Enter the Username and Password. Click the **OK** button.

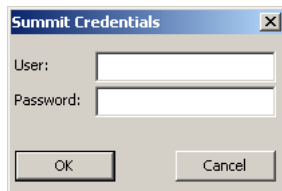

10. Verify the device is authenticated by reviewing the Status tab. When the device is properly configured, the indicates the device is Authenticated and the method used.
11. The sign-on screen is displayed after a reboot.

Note: See [Configuring the Profile](#) (page 6-18) for more details.

If a user enters invalid credentials and clicks **OK**, the device associates but does not authenticate. The user is again prompted to enter credentials.

If the user clicks the **Cancel** button, the device does not associate. The user is not prompted again for credentials until:

- the device is rebooted,
- the radio is disabled then enabled,
- the **Reconnect** button on the is clicked or
- the profile is modified and the **Commit** button is clicked.

To Use Windows Username and Password

Please see [Logon Options](#) (page 6-13) for information.

Windows Certificate Store vs. Certs Path

Note: It is important that all dates are correct on the Thor VM1 and host computers when using any type of certificate. Certificates are date sensitive and if the date is not correct authentication will fail.



If using the Windows Certificate Store, the Windows Account must have a password. The password cannot be left blank. The Summit Client Utility uses the Windows user account credentials to access the Certificate Store. The Windows user account credentials need not be the same as the credentials entered in the Summit Client Utility.

User Certificates

EAP-TLS authentication requires a user certificate. The user certificate must be stored in the Windows certificate store.

- To generate the user certificate, see [Generate a User Certificate](#) (page 6-35).
- To import the user certificate into the Windows certificate store, see [Install a User Certificate](#) (page 6-37).
- A Root CA certificate is also needed. Refer to the section below.

Root CA Certificates

Root CA certificates are required for EAP/TLS, PEAP/GTC and PEAP/MSCHAP. Two options are offered for storing these certificates. They may be imported into the Windows certificate store or copied into the Certs Path directory.

Certs Path

1. See [Generate a Root CA Certificate](#) (page 6-32) and follow the instructions to download the Root Certificate to a PC.
2. Copy the certificate to specified directory on the mobile device. The default location for Certs Path is C:\Program Files\Summit\certs. A different location may be specified by using the Certs Path global variable.
3. When completing the Credentials screen for the desired authentication, do not check the **Use MS store** checkbox after checking the **Validate server** checkbox.
4. Enter the certificate name in the CA Cert text box.
5. Click **OK** to exit the Credentials screen and then **Commit** to save the profile changes.

Windows Certificate Store

1. See [Generate a Root CA Certificate](#) (page 6-32) and follow the instructions to download the Root Certificate to a PC.
2. To import the certificate into the Windows store, See [Install a Root CA Certificate](#) (page 6-34).
3. When completing the Credentials screen for the desired authentication, be sure to check the **Use MS store** checkbox after checking the **Validate server** checkbox.
4. The default is to use all certificates in the store. If this is OK, skip to the last step.
5. Otherwise, to select a specific certificate click on the **Browse (...)** button.

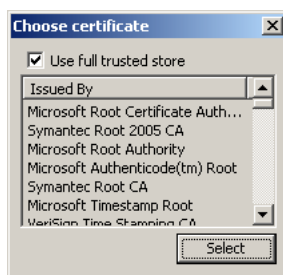

-
6. Uncheck the **Use full trusted store** checkbox.
 7. Select the desired certificate and click the **Select** button to return the selected certificate to the CA Cert text box.
 8. Click **OK** to exit the Credentials screen and then **Commit** to save the profile changes.

Configuring the Profile

Use the instructions in this section to complete the entries on the Profile tab according to the type of wireless security used by your network. The instructions that follow are the minimum required to successfully connect to a network. Your system may require more parameters than are listed in these instructions. Please see your system administrator for complete information about your network and its wireless security requirements.

To begin the configuration process:

- On the **Main** click the **Admin Login** button and enter the password.
- If using a single profile, edit the default profile with the parameters for your network. Select the Default profile from the pull-down menu.
- Make any desired parameter changes as described in the applicable following section determined by network security type and click the **Commit** button to save the changes.

IMPORTANT – Remember to click the Commit button after making changes to ensure the changes are saved. Many versions of the SCU display a reminder if the Commit button is not clicked before an attempt is made to close or browse away from the tab in focus if there are unsaved changes.

If changes are made to the *stored credentials*, click Commit to save those changes first before making any additional changes.

No Security

To connect to a wireless network with no security, make sure the following profile options are used.

1. Enter the **SSID** of the Access Point assigned to this profile
2. Set **EAP Type** to **None**
3. Set **Encryption** to **None**
4. Set **Auth Type** to **Open**

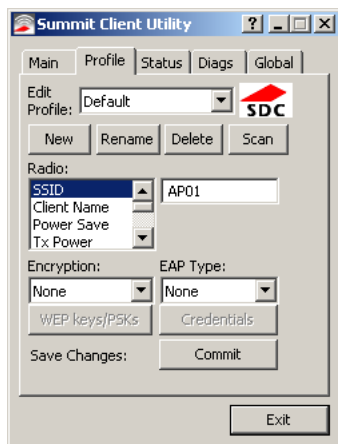

Once configured, click the **Commit** button.

Ensure the correct Active Profile is selected on the **Main** tab and restart. The SCU Main tab shows the device is associated after the radio connects to the network.

WEP

To connect using WEP, make sure the following profile options are used.

1. Enter the **SSID** of the Access Point assigned to this profile
2. Set **EAP Type** to **None**
3. Set **Encryption** to **WEP** or **Manual WEP** (depending on SCU version)
4. Set **Auth Type** to **Open**

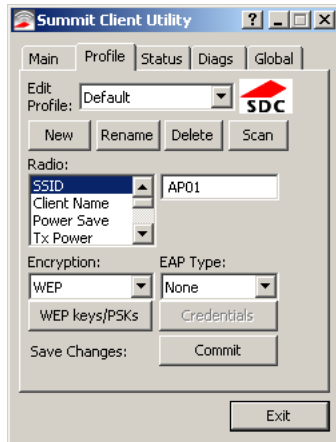

Click the **WEP keys/PSKs** button.

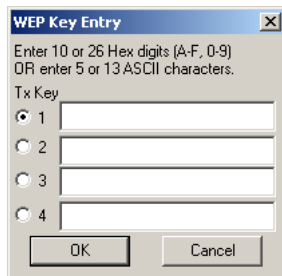

Valid keys are 10 hexadecimal or 5 ASCII characters (for 40-bit encryption) or 26 hexadecimal or 13 ASCII characters (for 128-bit encryption). Enter the key(s) and click **OK**.

Once configured, click the **Commit** button.

Ensure the correct Active Profile is selected on the **Main** tab and restart. The SCU Main tab shows the device is associated after the radio connects to the network.

LEAP

To use LEAP (without WPA, also called WEP-LEAP), make sure the following profile options are used.

1. Enter the **SSID** of the Access Point assigned to this profile
2. Set **EAP Type** to LEAP
3. Set **Encryption** to **WEP EAP** or **Auto WEP** (depending on SCU version)
4. Set **Auth Type** as follows:
5. If the Cisco/CCX certified AP is configured for open authentication, set the **Auth Type** radio parameter to **Open**.
6. If the AP is configured to use shared key or passphrase, set the Auth Type radio parameter to **Shared**.
7. If the AP is configured for network EAP only, set the **Auth Type** radio parameter to **LEAP**.

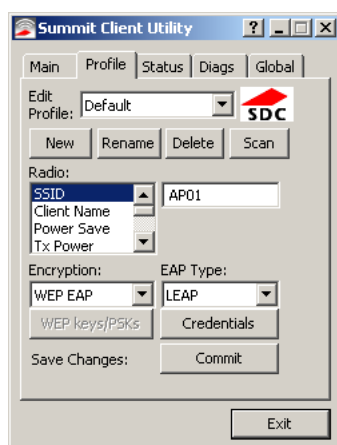

See [Sign-On vs. Stored Credentials](#) (page 6-15) for information on entering credentials.

To use Stored Credentials, click on the **Credentials** button. No entries are necessary for Sign-On Credentials as the user will be prompted for the Username and Password when connecting to the network.

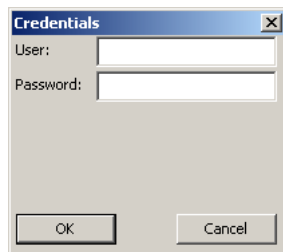

Enter the Domain\Username (if the Domain is required), otherwise enter the Username.

Enter the password. Click **OK** then click **Commit**.

Ensure the correct Active Profile is selected on the **Main** tab and restart. The SCU Main tab shows the device is associated after the radio connects to the network.

PEAP/MSCHAP

To use PEAP/MSCHAP, make sure the following profile options are used.

1. Enter the **SSID** of the Access Point assigned to this profile
2. Set **EAP Type** to **PEAP-MSCHAP**
3. Set **Encryption** to **WPA TKIP**
4. Set **Auth Type** to **Open**

To use another encryption type, select WPA CCKM, WPA2 AES or WPA2 CCKM for encryption and complete other entries as detailed in this section.

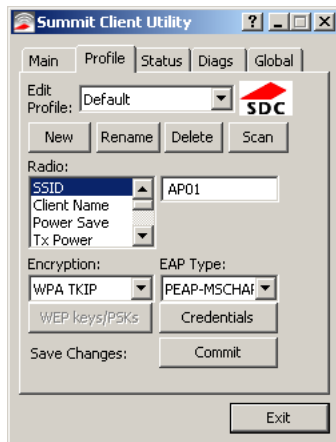

See [Sign-On vs. Stored Credentials](#) (page 6-15) for information on entering credentials.

Click the **Credentials** button.

- No entries except the CA Certificate Filename are necessary for Sign-On Credentials as the user will be prompted for the User Name and Password when connecting to the network.
- For Stored Credentials, User, Password and the CA Certificate Filename must be entered.

Enter these items as directed below.

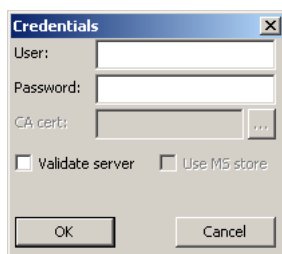

Enter the Domain\Username (if the Domain is required), otherwise enter the Username.

Enter the password.

Leave the CA Certificate File Name blank for now.

Click **OK** then click **Commit**. Ensure the correct Active profile is selected on the **Main** tab.

See [Windows Certificate Store vs. Certs Path](#) (page 6-17) for more information on certificate storage.

Once successfully authenticated, import the CA certificate into the Windows certificate store. Return to the Credentials screen and check the **Validate server** checkbox.

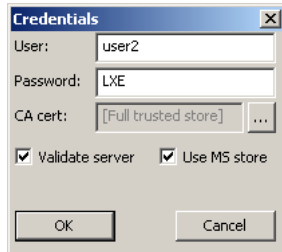

If using the Windows certificate store:

1. Check the **Use MS store** checkbox. The default is to use the Full Trusted Store.
2. To select an individual certificate, click on the **Browse** button.
3. Uncheck the **Use full trusted store** checkbox.
4. Select the desired certificate and click Select. You are returned to the Credentials screen.
5. Click **OK** then click **Commit**.

If using the Certs Path option:

1. Leave the **Use MS store** box unchecked.
2. Enter the certificate filename in the CA Cert text box.
3. Click **OK** then click **Commit**.

The device should be authenticating the server certificate and using PEAP/MSCHAP for the user authentication.

Ensure the correct Active Profile is selected on the **Main** tab and restart. The SCU Main tab shows the device is associated after the radio connects to the network.

Note: The date must be properly set on the device to authenticate a certificate.

PEAP/GTC

To use PEAP/GTC, make sure the following profile options are used.

1. Enter the **SSID** of the Access Point assigned to this profile
2. Set **EAP Type** to **PEAP-GTC**
3. Set **Encryption** to **WPA TKIP**
4. Set **Auth Type** to **Open**

To use another encryption type, select WPA CCKM, WPA2 AES or WPA2 CCKM for encryption and complete other entries as detailed in this section.

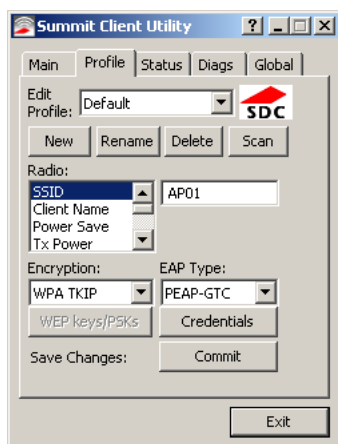

See [Sign-On vs. Stored Credentials](#) (page 6-15) for information on entering credentials.

Click the **Credentials** button.

- No entries except the CA Certificate Filename are necessary for Sign-On Credentials as the user will be prompted for the User Name and Password when connecting to the network.

Enter these items as directed below.

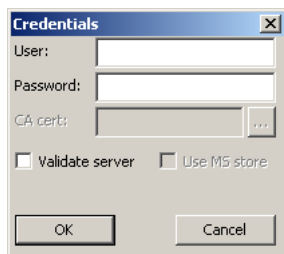

Enter the Domain\Username (if the Domain is required), otherwise enter the Username.

Enter the password.

Leave the CA Certificate File Name blank for now.

Click **OK** then click **Commit**. Ensure the correct Active Profile is selected on the **Main** tab.

See [Windows Certificate Store vs. Certs Path](#) (page 6-17) for more information on certificate storage.

Once successfully authenticated, import the CA certificate into the Windows certificate store. Return to the Credentials screen and check the **Validate server** checkbox.

Note: Some servers may be configured to allow only a single use of the password for PEAP/GTC. In this case, wait for the token to update with a new password before attempting to validate the server. Then enter the new password, check the Validate Server checkbox and proceed with the certificate process below.

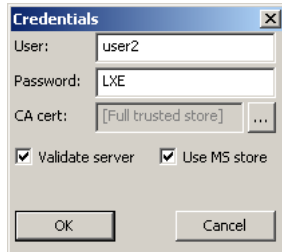

If using the Windows certificate store:

1. Check the **Use MS store** checkbox. The default is to use the Full Trusted Store.
2. To select an individual certificate, click on the **Browse** button.
3. Uncheck the **Use full trusted store** checkbox.
4. Select the desired certificate and click **Select**. You are returned to the Credentials screen.
5. Click **OK** then click **Commit**.

If using the Certs Path option:

1. Leave the **Use MS store box** unchecked.
2. Enter the certificate filename in the CA Cert text box.
3. Click **OK** then click **Commit**.

The device should be authenticating the server certificate and using PEAP/GTC for the user authentication.

Ensure the correct Active Profile is selected on the **Main** tab and restart. The SCU Main tab shows the device is associated after the radio connects to the network.

Note: The date must be properly set on the device to authenticate a certificate.

WPA/LEAP

To use WPA/LEAP, make sure the following profile options are used.

1. Enter the **SSID** of the Access Point assigned to this profile
2. Set **EAP Type** to **LEAP**
3. Set **Encryption** to **WPA TKIP**
4. Set **Auth Type** as follows:
5. If the Cisco/CCX certified AP is configured for open authentication, set the **Auth Type** radio parameter to **Open**.
6. If the AP is configured to use shared key or passphrase, set the Auth Type radio parameter to **Shared**.
7. If the AP is configured for network EAP only, set the **Auth Type** radio parameter to **LEAP**.

To use another encryption type, select WPA CCKM, WPA2 AES or WPA2 CCKM for encryption and complete other entries as detailed in this section.

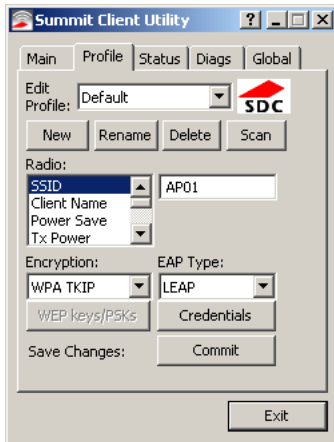

See [Sign-On vs. Stored Credentials](#) (page 6-15) for information on entering credentials.

To use Stored Credentials, click on the **Credentials** button. No entries are necessary for Sign-On Credentials as the user will be prompted for the Username and Password when connecting to the network.

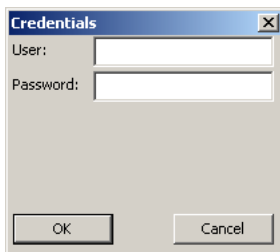

Enter the Domain\Username (if the Domain is required), otherwise enter the Username.

Enter the password.

Click **OK** then click the **Commit** button.

Ensure the correct Active Profile is selected on the **Main** tab and restart. The SCU Main tab shows the device is associated after the radio connects to the network.

EAP-FAST

To use EAP-FAST, make sure the following profile options are used.

1. Enter the **SSID** of the Access Point assigned to this profile
2. Set **EAP Type** to **EAP-FAST**
3. Set **Encryption** to **WPA TKIP**
4. Set **Auth Type** to **Open**

To use another encryption type, select WPA CCKM, WPA2 AES or WPA2 CCKM for encryption and complete other entries as detailed in this section.

The SCU supports EAP-FAST with automatic or manual PAC provisioning. With automatic PAC provisioning, the user credentials, whether entered on the saved credentials screen or the sign on screen, are sent to the RADIUS server. The RADIUS server must have auto provisioning enabled to send the PAC provisioning credentials to the Thor VM1.

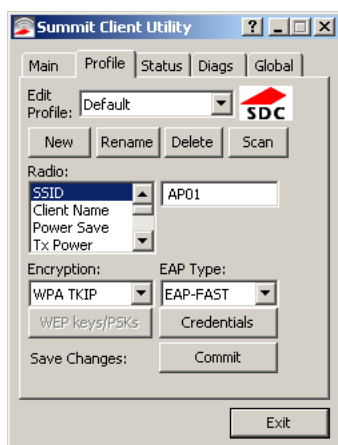

For automatic PAC provisioning, once a username/password is authenticated, the PAC information is stored on the Thor VM1. The same username/password must be used to authenticate each time. See the note below for more details.

For manual PAC provisioning, the PAC filename and Password must be entered.

See [Sign-On vs. Stored Credentials](#) (page 6-15) for information on entering credentials.

The entries on the Credentials screen are determined by the type of credentials (stored or sign on) and the type of PAC provisioning (automatic or manual).

Click on the **Credentials** button.

To use Stored Credentials, click on the **Credentials** button. No entries are necessary for Sign-On Credentials with automatic PAC provisioning as the user will be prompted for the Username and Password when connecting to the network.

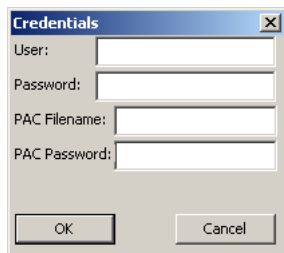

To use Sign-On credentials:

- Do not enter a User and Password as the user will be prompted for the Username and Password when connecting to the network.

To use Stored Credentials:

-
- Enter the Domain\Username (if the Domain is required), otherwise enter the Username.
 - Enter the password.

To use Automatic PAC Provisioning:

- No additional entries are required.

To use manual PAC Provisioning:

- Enter the PAC Filename and PAC Password.
- The PAC file must be copied to the directory specified in the Certs Path global variable. The PAC file must not be read only.

Ensure the correct Active Profile is selected on the **Main** tab and restart. The SCU Main tab shows the device is associated after the radio connects to the network.

Note: When using Automatic PAC Provisioning, once authenticated, there is a file stored in the C:\Program Files\Summit\certs directory with the PAC credentials. If the username is changed, that file must be deleted. The filename is autoP.00.pac.

EAP-TLS

To use EAP-TLS, make sure the following profile options are used.

1. Enter the **SSID** of the Access Point assigned to this profile
2. Set **EAP Type** to **EAP-TLS**
3. Set **Encryption** to **WPA TKIP**
4. Set **Auth Type** to **Open**

To use another encryption type, select WPA CCKM, WPA2 AES or WPA2 CCKM for encryption and complete other entries as detailed in this section.

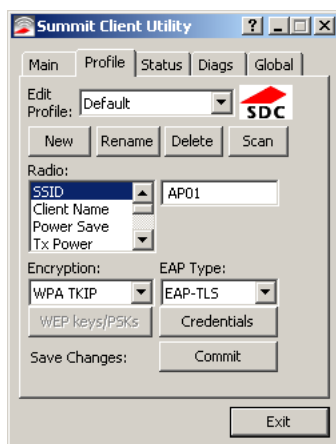

See [Sign-On vs. Stored Credentials](#) (page 6-15) for information on entering credentials.

Click the **Credentials** button.

- No entries except the User Certificate Filename and the CA Certificate Filename are necessary for Sign-On Credentials as the user will be prompted for the User Name when connecting to the network.
- For Stored Credentials, User Certificate Filename and the CA Certificate Filename must be entered.

Enter these items as directed below.

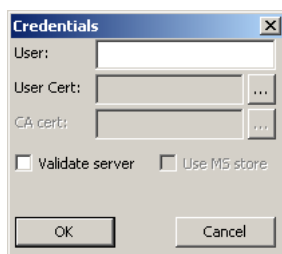

Enter the Domain\Username (if the Domain is required), otherwise enter the Username.

Select a user certificate from the Windows certificate store. Use the **Browse** button to locate the User Cert from the certificate store. Highlight the desired certificate and press the **Select** button. The name of the certificate is displayed in the User Cert box.

Some versions of the SCU require a User Cert password. If this entry field is present, enter the password for the user certificate in the User Cert pwd box.

If there are no user certificates in the Windows certificate store, follow these instructions for [Generate a User Certificate](#) (page 6-35) and [Install a User Certificate](#) (page 6-37).

See [Windows Certificate Store vs. Certs Path](#) (page 6-17) for more information on CA certificate storage.

Check the **Validate server** checkbox.

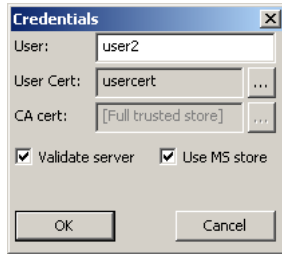

If using the Windows certificate store:

1. Check the **Use MS store** checkbox. The default is to use the Full Trusted Store.
2. To select an individual certificate, click on the Browse button.
3. Uncheck the **Use full trusted store** checkbox.
4. Select the desired certificate and click **Select**. You are returned to the Credentials screen.
5. Click **OK** then click **Commit**.

If using the Certs Path option:

1. Leave the Use MS store box unchecked.
2. Enter the certificate filename in the CA Cert text box.
3. Click **OK** then click **Commit**.

The Thor VM1 should be authenticating the server certificate and using EAP-TLS for the user authentication.

Ensure the correct Active Profile is selected on the **Main** tab and restart. The SCU Main tab shows the device is associated after the radio connects to the network.

See [Certificates](#) (page 6-32) for information on generating a Root CA certificate or a User certificate.

Note: The date must be properly set on the device to authenticate a certificate.

WPA PSK

To connect using WPA/PSK, make sure the following profile options are used:

1. Enter the **SSID** of the Access Point assigned to this profile
2. Set **EAP Type** to **None**
3. Set **Encryption** to **WPA PSK** or **WPA2 PSK**
4. Set **Auth Type** to **Open**

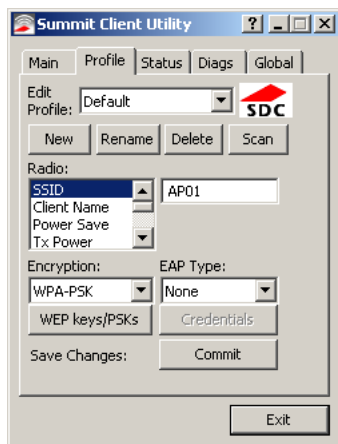

Click the **WEP keys/PSKs** button.

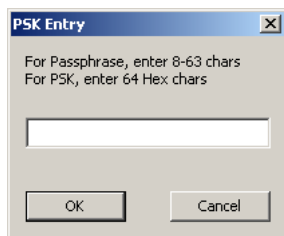

This value can be 64 hex characters or an 8 to 63 byte ASCII value. Enter the key and click **OK**.

Once configured, click the **Commit** button.

Ensure the correct Active Profile is selected on the **Main** tab and restart. The SCU Main tab shows the device is associated after the radio connects to the network.

Certificates

Note: Please refer to the Security Primer to prepare the Authentication Server and Access Point for communication.

Note: It is important that all dates are correct on the Thor VM1 and host computers when using any type of certificate. Certificates are date sensitive and if the date is not correct authentication will fail.



If using the Windows Certificate Store, the Windows Account must have a password. The password cannot be left blank. The Summit Client Utility uses the Windows user account credentials to access the Certificate Store. The Windows user account credentials need not be the same as the entered in the Summit Client Utility.

Quick Start

Root Certificates are necessary for EAP-TLS, PEAP/GTC and PEAP/MSCHAP.

1. [Generate a Root CA Certificate](#) (page 6-32) either from the Thor VM1 or using a PC.
2. If a PC was used to request the certificate, copy the certificate to the Thor VM1.
3. [Install a Root CA Certificate](#) (page 6-34).

User Certificates are necessary for EAP-TLS

1. [Generate a User Certificate](#) (page 6-35) either from the Thor VM1 or using a PC.
2. If a PC was used to request the certificate, copy the certificate to the Thor VM1.
3. [Install a User Certificate](#) (page 6-37).

Generate a Root CA Certificate

Note: It is important that all dates are correct on the Thor VM1 and host computers when using any type of certificate. Certificates are date sensitive and if the date is not correct authentication will fail.

The easiest way to get the root CA certificate is to use a browser on a PC or the Thor VM1 to navigate to the Certificate Authority. To request the root CA certificate, open a browser to

http://<CA IP address>/certsrv.

Sign into the CA with any valid username and password.



Welcome

Use this Web site to request a certificate for your Web browser, e-mail client, or other program. By using a certificate, you can verify your identity to people you communicate with over the Web, sign and encrypt messages, and, depending upon the type of certificate you request, perform other security tasks.

You can also use this Web site to download a certificate authority (CA) certificate, certificate chain, or certificate revocation list (CRL), or to view the status of a pending request.

For more information about Certificate Services, see [Certificate Services Documentation](#).

Select a task:

[Request a certificate](#)

[View the status of a pending certificate request](#)

[Download a CA certificate, certificate chain, or CRL](#)

Click the **Download a CA certificate, certificate chain or CRL** link.

Make sure the correct root CA certificate is selected in the list box.

Download a CA Certificate, Certificate Chain, or CRL

To trust certificates issued from this certification authority, [install this CA certificate chain](#).

To download a CA certificate, certificate chain, or CRL, select the certificate and encoding method.

CA certificate:

Current

Encoding method:

- DER
 Base 64

[Download CA certificate](#)

[Download CA certificate chain](#)

[Download latest base CRL](#)

[Download latest delta CRL](#)

Click the **DER** button.

To download the CA certificate, click on the **Download CA certificate** link.



Click the **Save** button and save the certificate. Make sure to keep track of the name and location of the certificate.

Next install the certificate on the Thor VM1.

Install a Root CA Certificate

Note: This section is only if the Windows certificate store is used. If the certificate store is not used, copy the certificate to the C:\Program Files\Summit\certs folder or other path specified in the Summit Certs global parameter.

Copy the certificate file to the Thor VM1. The certificate file has a .CER extension. Locate the file and double-tap on it. If presented with a security warning, confirm that you want to open the file.

If the Certificate Wizard does not start automatically when you double-tap the certificate .CER file:

1. Select **Start > Run** and type **certmgr.msc** in the text box and tap **OK** (*Windows Embedded Standard 2009 only*).
2. In the left pane, right-click **Trusted Root Certificate Authorities** and select **All Tasks > Import**.
3. The Certificate Import Wizard starts.
4. Tap **Next** and use the **Browse...** button to locate the Root certificate copied to the Thor VM1 then tap **Open**.
5. The certificate filename and path are displayed. Tap **Next**.

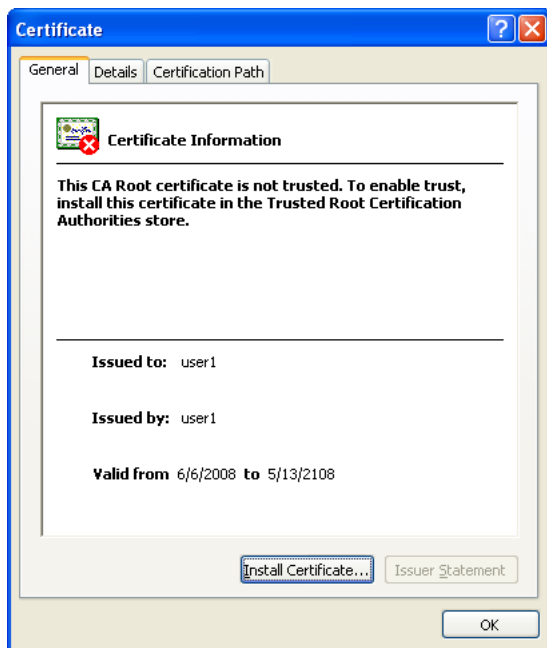

Tap the **Install Certificate** button.

The certificate import wizard starts. Tap **Next**.

1. Allow Windows to automatically select the certificate store.
2. Tap **Next** and **Finish**.
3. An import successful message is displayed.

Generate a User Certificate

The easiest way to get the user certificate is to use the browser on the Thor VM1 or a PC to navigate to the Certificate Authority. To request the user certificate, open a browser to

http://<CA IP address>/certsrv.

Sign into the CA with the username and password of the person who will be logging into the mobile device.



This process saves a user certificate file. There is no separate private key file as used on Windows CE devices.

Microsoft Certificate Services [Home](#)

Welcome

Use this Web site to request a certificate for your Web browser, e-mail client, or other program. By using a certificate, you can verify your identity to people you communicate with over the Web, sign and encrypt messages, and, depending upon the type of certificate you request, perform other security tasks.

You can also use this Web site to download a certificate authority (CA) certificate, certificate chain, or certificate revocation list (CRL), or to view the status of a pending request.

For more information about Certificate Services, see [Certificate Services Documentation](#).

Select a task:

- [Request a certificate](#)
- [View the status of a pending certificate request](#)
- [Download a CA certificate, certificate chain, or CRL](#)

Click the **Request a certificate** link.

Microsoft Certificate Services [Home](#)

Request a Certificate

Select the certificate type:

[User Certificate](#)

Or, submit an [advanced certificate request](#).

Click on the **User Certificate** link.

User Certificate - Identifying Information

No further identifying information is required. To complete your certificate, press submit:

[More Options >>](#)

Click on the **Submit** button. If there is a message box asking if you want to confirm the request, click **Yes**.

The User Certificate is issued.

Certificate Issued

The certificate you requested was issued to you.



[Install this certificate](#)

Install the user certificate on the requesting computer by clicking the **Install this certificate** link.

If the requesting computer is the Thor VM1, then the process is finished. Otherwise, export the certificate as described below.

Exporting a User Certificate

Select **Tools > Internet Options > Content** and click the **Certificates** button.

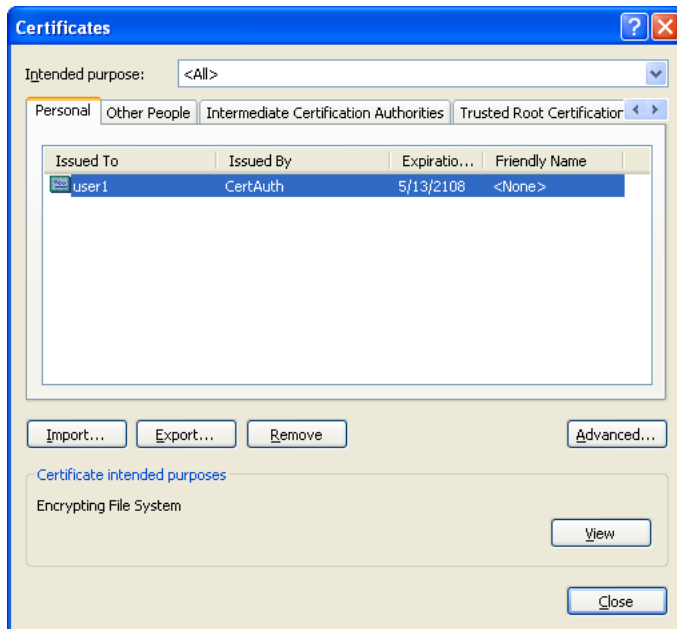

Make sure the **Personal** tab is selected. Highlight the certificate and click the **Export** button.

The Certificate Export Wizard is started

Select **Yes, export the private key** and click Next.

Do you want to export the private key with the certificate?

- Yes, export the private key
 No, do not export the private key

Uncheck **Enable strong protection** and check **Next**. The certificate type must be PKCS #12 (.PFX).

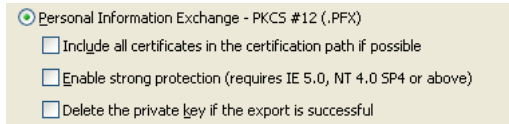

When the private key is exported, you must enter the password, confirm the password and click **Next**. Be sure to remember the password as it is needed when installing the certificate.

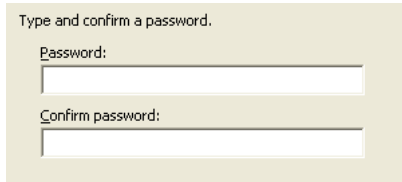

Supply the file name for the certificate. Use the **Browse** button to select the folder where you wish to store the certificate. The certificate is saved with a .PFX extension.



Click Finish. and OK to close the Successful Export message.

Locate the User Certificate in the specified location. Copy to the Thor VM1. Install the User certificate.

Install a User Certificate

After generating and exporting the user certificate, install the user certificate.

1. Copy the certificate from the PC to the Thor VM1.
2. Locate the certificate file (it has a .PFX extension) and double-click on it. If clicking on the certificate file does not launch the certificate import wizard, follow the [Manually Initiate Certificate Installation](#) (page 6-38) before continuing the instructions below.
3. The certificate import wizard starts. Tap **Next**.
4. Confirm the certificate file name and location.
5. Tap **Next**.
6. You are prompted for the password that was assigned when the certificate was exported.



7. It is not necessary to select either of the checkboxes displayed above.
8. Enter the password and tap **Next**.
9. On the next screen, allow Windows to automatically select the certificate store, then click **Next** and **Finish**. An import successful message is displayed.

Manually Initiate Certificate Installation

If the Certificate Wizard does not start automatically when you double-tap the certificate .PFX file:

1. Select **Start > Run** and type **certmgr.msc** in the text box and tap **OK**.
2. In the left pane, right-click **Personal** and select **All Tasks > Import**.
3. The Certificate Import Wizard starts.
4. Tap **Next** and use the **Browse...** button to locate the User certificate copied to the Thor VM1. If necessary, change the file type drop down list at the bottom of the explorer window from **.cer* to **.pfx*. After selecting the .PFX file, tap **Open**.
5. The certificate filename and path are displayed. Tap **Next**.
6. Return to the installation instructions above.

OneClick Internet

This section contains the User Manual for the customized version of WebToGo's OneClick Internet for the Honeywell Thor VM1. OneClick Internet is installed by Honeywell on all Thor VM1s equipped with a WWAN radio. Available carriers and OneClick features may vary by device.

OneClick Internet provides:

- Internet connection management
- Email download
- SMS Management
- Contact management for SIM and Microsoft Outlook
- GPS Management

Since WebToGo OneClick Internet is preinstalled, it is present on the Windows Start Menu. A desktop icon is also provided.



Honeywell does not recommend using standby on the Thor VM1 while the WWAN connection is active. When exiting standby, a delay of one minute or more may occur as the WWAN radio reads firmware files and initializes before reconnecting. If this delay is acceptable to the user, standby may be enabled. When the One Click Internet utility is displayed on screen and the Thor VM1 enters standby, the touch screen may remain inactive for 10-15 seconds after the Thor VM1 resumes from standby.

Preparing for Initial Use on the Thor VM1

Install SIM Card

If using a CDMA carrier such as Verizon, skip this step because a SIM card is not used.

[Install SIM Card](#) (page 4-57) in the Thor VM1.

Load Firmware

While the OneClick Internet utility is preinstalled, it is necessary to load the GOBI radio firmware for your selected carrier such as AT&T, T-Mobile or Verizon.

Note: For carriers requiring a SIM card, the firmware may automatically be selected when a SIM card is installed in the Thor VM1.

Double-tap the OneClick Internet icon on the Thor VM1 desktop.



OneClick
Internet

Tap the **Settings** button and select the **Firmware** tab. Select the firmware for your carrier from the list and tap **Change**.

For more details, see [OneClick Internet Connection Manager](#) (page 6-56) and the [Firmware](#) (page 6-48) tab.

Activation

This step is only necessary for Verizon.

You need the IMEI number for the Thor VM1 when you contact Verizon prior to activating service on the Thor VM1. The IMEI number can be found on the [Info](#) (page 6-48) tab.

The activation screen is displayed automatically after the Verizon firmware is selected. If the activation screen is not automatically displayed, double-tap the **OneClick Internet** icon on the desktop. Select **Settings > General** tab and tap the **Activate** button.



Make sure **Automated Activation** is selected and tap **Next**.



Tap **Next** to complete the activation.

Once the activation is completed, OneClick Internet may be minimized to the tray.

 To verify your settings, tap on the OneClick Internet icon in the system tray.

Tap **Settings**.

Tap the **Network** tab.



This screen contains the settings including the telephone number from the provider, in this case Verizon.

Using OneClick Internet

If OneClick Internet is not loaded, double-tap the desktop icon to load it. If OneClick Internet is loaded but minimized to the system tray, tap the OneClick Internet icon in the system tray to maximize it.

Connection Management

1. Launch the OneClick Internet Connection Manager and wait until the status icon is blue indicating ready.
2. If there is a problem, verify the SIM card is installed (AT&T, T-Mobile only), the proper firmware has been loaded, etc.
3. If PIN security is used, a popup window prompts for the SIM PIN.
4. Create a connection profile on the **Settings** menu.
5. Tap the **Connect** button.



The signal strength is indicated as well as the name of the mobile network you are using and the status of the WWAN device. Tap the **Disconnect** button to end the session.



Menu Buttons

Radio Button



The Radio button allows you to switch the WWAN radio on and off to save power or to disable the radio in instances where it is not desired (such as during airplane travel).

When the radio is switched off, the button is red. When on, it is green. If the radio is disabled by a hardware switch or if the device is not available, the button is disabled and is light gray/white.

Statistics Button



The Statistics area provides advanced information about the connection. Values displayed are approximate.

Tap the **Statistics** button to enable the statistics viewing area, which is below the main area. When the statistics are displayed, tapping the **Statistics** button again hides the statistics viewing area.



Data In:	The amount of data received during the current connection.
Data Out:	The amount of data sent during the current connection.
Total:	The total amount of data transferred during the current connection.
Speed:	The current data transfer rate.
Max. Speed:	The maximum data transfer rate during this connection.
Time:	The duration of the current connection.

Update Button



OneClick Internet provides a built-in online update functionality that allows for an automatic update of OneClick Internet application, device drivers, and APN database.

Honeywell **DOES NOT** recommend using this option. Contact [Technical Assistance](#) (page 9-1) or information on upgrading to another version of OneClick Internet.

The update is triggered by pressing the update button. The application will check the WebToGo server, if updates are available, and offer them for download if suitable.

In order to start the update, select a file from the list of available updates and tap **OK**.

Help Button



OneClick Internet includes online help that can be accessed by tapping the Help button.

Settings Button



Access the Settings menu by tapping the Settings button on the main window.

The following tabs are available:





- Profile
- Network
- History
- PIN
- Info
- Firmware
- General

Profile

A screenshot of a mobile application's Settings window. The window has a black title bar with the word "Settings" in white and a red close button in the top right corner. Below the title bar is a tabbed interface with six tabs: "Profile", "Network", "History", "PIN", "Info", and "Firmw". The "Profile" tab is selected and highlighted. The main content area is white and contains several input fields and checkboxes. The fields are: "Profile Name:" (a text box), "APN:" (a text box), "Username:" (a text box), and "Password:" (a text box). To the right of these fields are four circular icons: a document with a plus sign, a document with a minus sign, a document with an 'X', and a document with a plus sign. Below these fields are two checkboxes: "Use automatic DNS-settings" (checked) and "Use Proxy Server" (unchecked). Under "Use Proxy Server" are two more text boxes labeled "Proxy:" and "Port:". At the bottom of the form is a "Set Profile" button.

Create a connection profile to store connection information. Once a profile has been created, its name appears in the drop down Profiles list, which replaces the Profile Name text box in the illustration above.

Buttons

Button	Description
	Create a new profile. When this option is selected, the Profile Name is a text box. Enter a name for the profile as well as other connection specific configuration. When finished, tap the Save button to save the new profile.
	Edit a current profile. Select a profile from the Profiles list and tap this button to edit the profile parameters. When finished, tap the Save button to save the profile changes.
	Delete a profile. Select a profile from the Profiles list and tap this button to delete the profile
	Save a profile. Save a new profile or save changes made when editing a profile.
	Set Profile. Select a profile from the Profiles list and tap this button to make it the active profile used for connection.

Parameters

Label	Description
Profile Name	Profile name - Assign a unique name for each profile.
APN	Access Point Name of the network operator. Contact your network operator for more information When you are using a CDMA network, the APN field does not appear.
Username	Username. Contact your network operator for more information
Password	Password. Contact your network operator for more information
DNS	Domain Name Server. Contact your network operator for more information. When Use Automatic DNS-settings is selected, no additional DNS entries are required. Otherwise, enter the DNS addresses.
Proxy Settings	Proxy Settings for your network. Contact your network operator for more information. When Use Proxy Server is selected, no additional proxy entries are required. Otherwise, enter the Proxy and the Port.

Network

The appearance of the network tab depends on the type of firmware selected.

Network with SIM Card

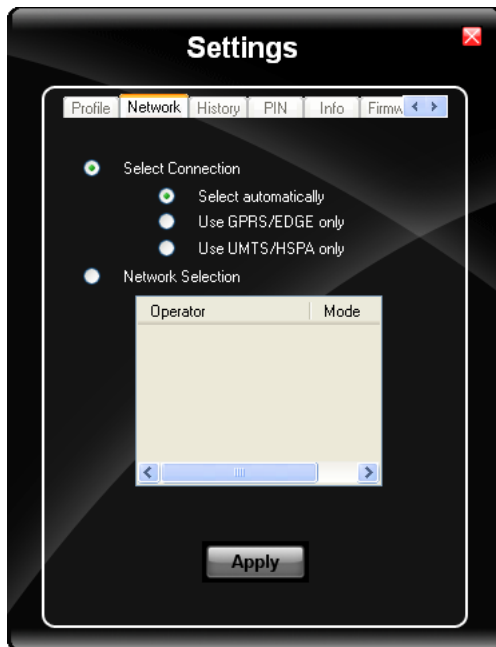

Select Connection

Label	Description
Select automatically	Selects the best suited network automatically
Use GPRS/EDGE only	Use only GPRS/EDGE for a connection
Use UMTS/HSPA only	Use only UMTS/HSPA for a connection.

Select and tap **Apply**. A “Network changed successfully” message is displayed.

Close the tab and view the signal strength icon in the main window. Once the signal strength is displayed, you can establish a connection.

Select Network

Use this option to select from available networks.

Note: When you are registered to a CDMA network, you cannot select the network. “All CDMA network” is shown instead.

*Note: The network list only appears if the connection setting is **Only use GPRS** or **Only use UMTS/HSPA**.*

Select the network and tap on the register button. If the change is successful you will see the message “Network changed successfully”.

This item is useful when traveling . Automatic mode selects the preferred network of your network operator.

If enabled, Network Selection displays a list of network options.

1. Automatic Selection
2. Retrieving Networks...

The currently registered network is marked.

CDMA Network

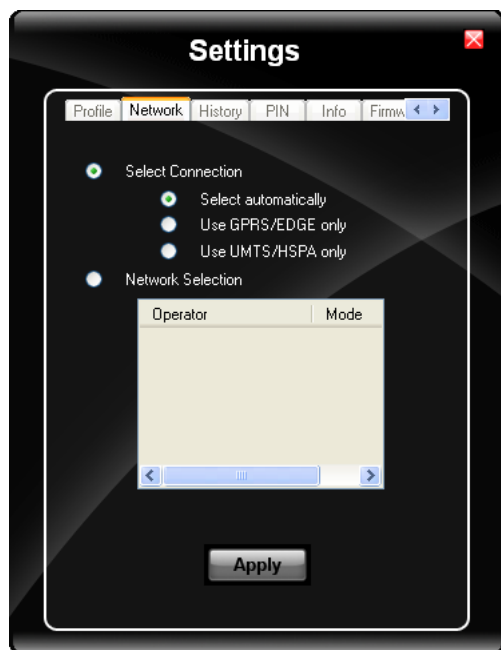

Information on the CDMA network is displayed. There are no editable parameters on this screen.

History

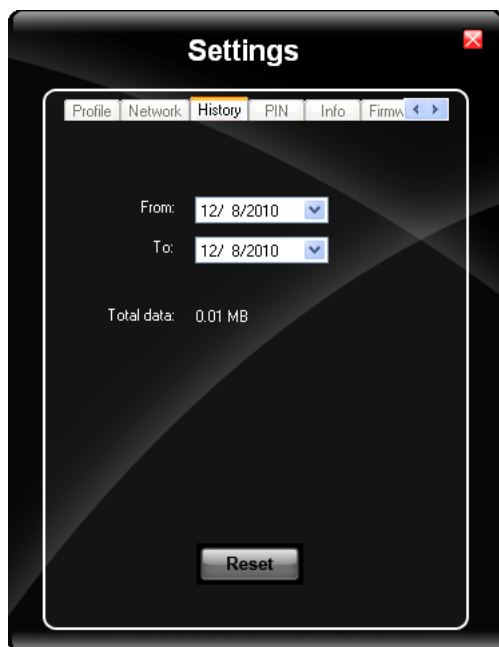

The history shows the data volume transferred in a specified time frame. Select the **From** and **To** dates to see the data volume sent/received in the specified period. Tap **Reset** to reset the counter.

PIN

You can Activate/Deactivate the PIN or Change the PIN.

Activate/Deactivate PIN

This tab is only displayed when a firmware is loaded that requires a SIM card (such as AT&T or T-Mobile).

By default, you have to enter the PIN each time you start WebToGo OneClick Internet using a modem card. Deactivate the PIN to avoid entering the PIN each time.

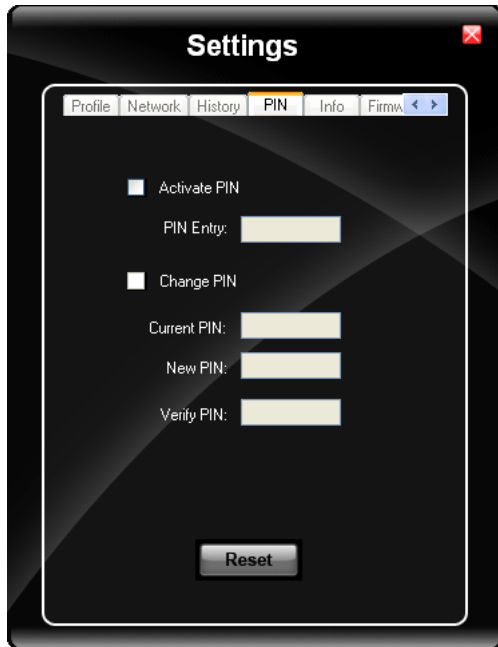

Change PIN

This dialog lets you change your PIN.

Label	Description
Current PIN	Enter the current PIN.
New PIN	Enter the new PIN.
Verify PIN	Verify the new PIN by entering it again.

Info

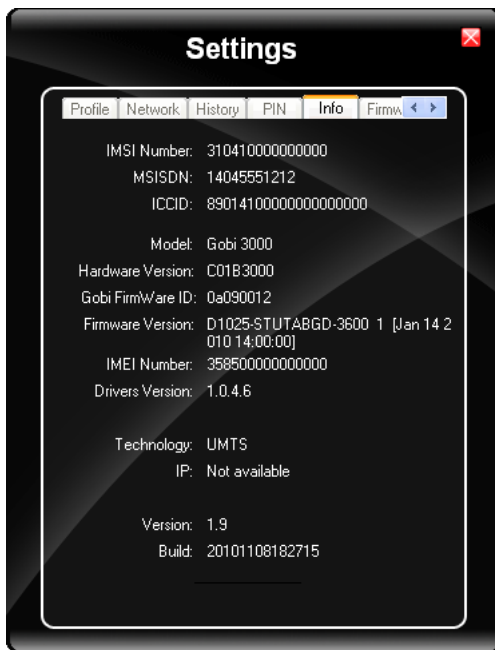

This tab displays SIM card, modem and system Information.

Firmware



OneClick Internet selects the correct Firmware matching your operator automatically, if a special firmware for your operator is available and a SIM card is inserted. If no specific firmware for your operator is available, generic firmware is selected. After a firmware has been selected, it appears as the **Current Profile**.

You can manually load your desired firmware. Select a new firmware manually by clicking the **Select New Profile** dropdown menu, selecting a firmware from the menu and tapping the **Change** button to load. To return to automatic firmware selection, choose **Automatic(UMTS)** in the dropdown menu.

Note: Switching between CDMA and UMTS firmware is not done automatically. You must select CDMA firmware manually to connect to CDMA networks. If you want to return to UMTS networks, you must manually select UMTS firmware.

Activation on CDMA

When CDMA Firmware is selected, the activation of the modem on the CDMA network starts automatically. During the process of loading CDMA firmware, an activation window pop up allowing a choice between **Manual Activation** and **Automated Activation**.

Label	Description
Manual Activation	Enter the requested items as direct by a representative from your carrier.
Automatic Activation	Use your modem to start an automated activation session

If you cancel the activation or if it fails, you can also start the activation manually by pressing the **Activate** button on the **General** tab.

General

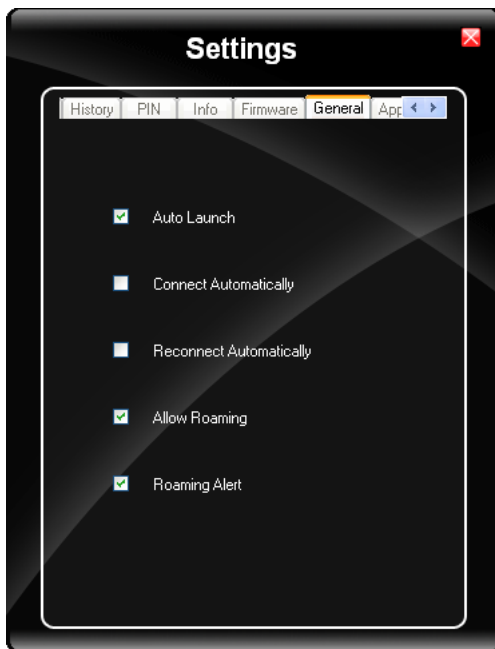

Label	Description
Auto Launch	When selected OneClick Internet launches automatically when the user starts the Thor VM1 and logs in.
Connect Automatically	When selected OneClick Internet automatically connects on start-up.
Reconnect Automatically	When selected OneClick Internet reconnects automatically when the Thor VM1 returns from standby or hibernate.
Allow roaming	When selected OneClick Internet allows connections in foreign networks. Use care when enabling roaming to avoid roaming charges.
Roaming Alert	When selected OneClick Internet displays an alert when roaming.

Label	Description
Gobi NDIS Auto Connect	When selected OneClick Internet connects automatically after powering up the operating system and before the user logs in.

Application

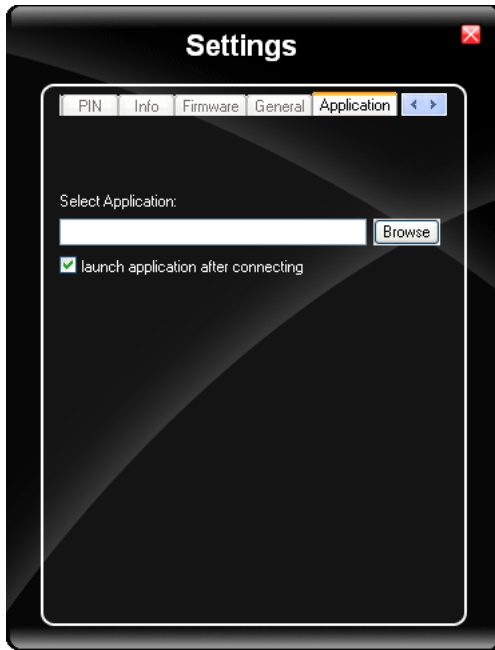







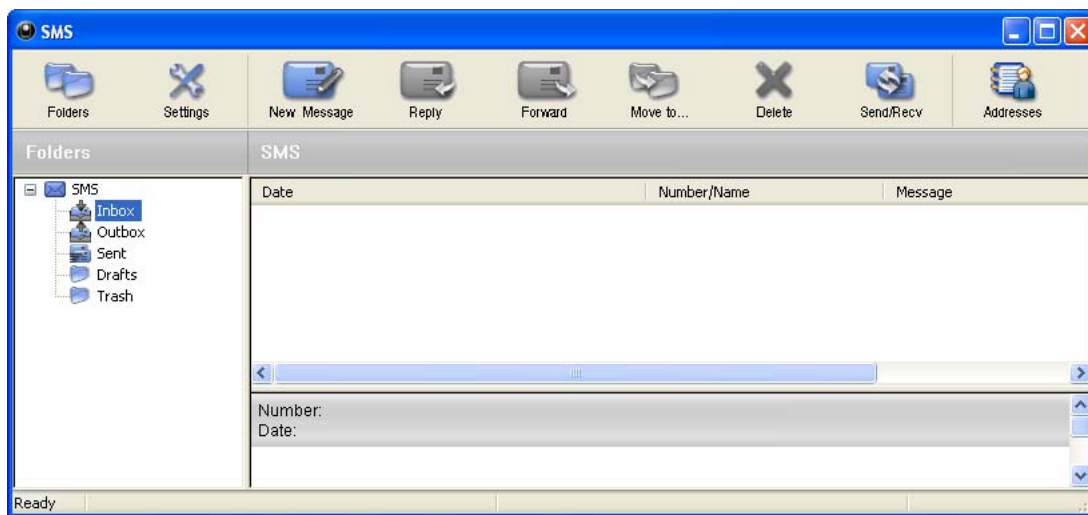

Use the **Application** tab to specify any application to launch automatically once the Internet connection is established. Use the Browse button to locate the desired application.

Application Buttons

SMS



The SMS Center window is split into menu bar, folder view, folder content and preview window. To manage your short messages you may:

Button	Description
 Folders	Manage SMS folders
 Settings	Change SMS settings
 New Message	Create new SMS/MMS messages
 Reply	Reply to SMS
 Forward	Forward SMS
 Move to...	Move SMS to a folder
 Delete	Delete SMS
 Send/Recv	Send and receive SMS/MMS (if supported)
 Addresses	Manage phone book contacts on SIM and in Email client.

Folder

By using this menu, you may change the folder structure of the SMS Center:

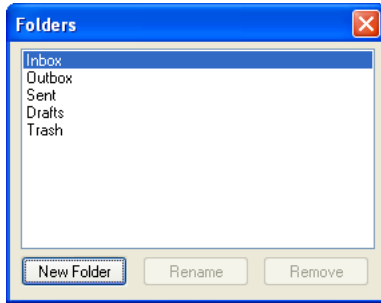

Button	Description
New Folder	Creates a new folder, name has to be unique
Rename	Renames an existing folder
Remove	Removes an existing folder (including the messages)

Note: Predefined folders can't be deleted or modified.

Settings

The settings window lets you change the deletion mode. You may choose whether to delete an SMS from the SMS Center, from the SIM or decide whether this should be asked at all. You may also activate an alarm signal when a new SMS arrives.

New SMS

The "New Message" window is used to enter the SMS text. You may also enter texts by copy & paste from other applications. The status bar at the lower right corner indicates the length of the SMS for your convenience: the first number tells you how many parts the SMS consists of (one part has max. 160 characters/unicode70), the second number counts down from 160/70 characters. The number in parenthesis () counts the total number of characters. The recipient for your SMS has to be entered in the "To" field. This can be either entered by typing digits or by clicking the "To" button to select a recipient from the address book. Recipient addresses may be taken from the SIM address book or from your Email client's contact folder. Just select an address and click OK. To send the message click "Send/Receive".

Reply

Highlight a message to which you want to reply, e.g. in the inbox folder, then click the "Reply" button. The "New Message" window opens and the recipient address is already filled in the "To" field. Continue as before when sending a new message.

Forward

Highlight a SMS, which you want to forward. Click the "Forward" button. The "New Message" window opens, however the message text is already copied. Continue as before when sending a new message.

Move SMS...

Highlight the SMS to be moved and click the "Move SMS" button. A small window opens that lets you select the destination folder. Select the folder to which the message should be moved, then click "Move".

Delete

Highlight the SMS which you want to delete. Click "Delete" to remove the message.

Send/Receive

Messages will be sent and/or received by clicking on this button.

Addresses

Clicking this button opens the address book. You may add new contacts to your personal address book or you may change existing addresses, delete addresses or exchange them with your SIM card and your Email client application, or export the data set.

Buttons	Description
New Contact	Create new contact.
Modify	Modify a contact.
Delete	Delete contacts, mark one or more and press the button.
Copy	Synchronization with MS Outlook.
Export	To export addresses you may select between two export formats: <ul style="list-style-type: none">• CSV (comma separated text format, usually read by spread sheet applications)• VCard (business card format, used by MS Outlook and other applications)

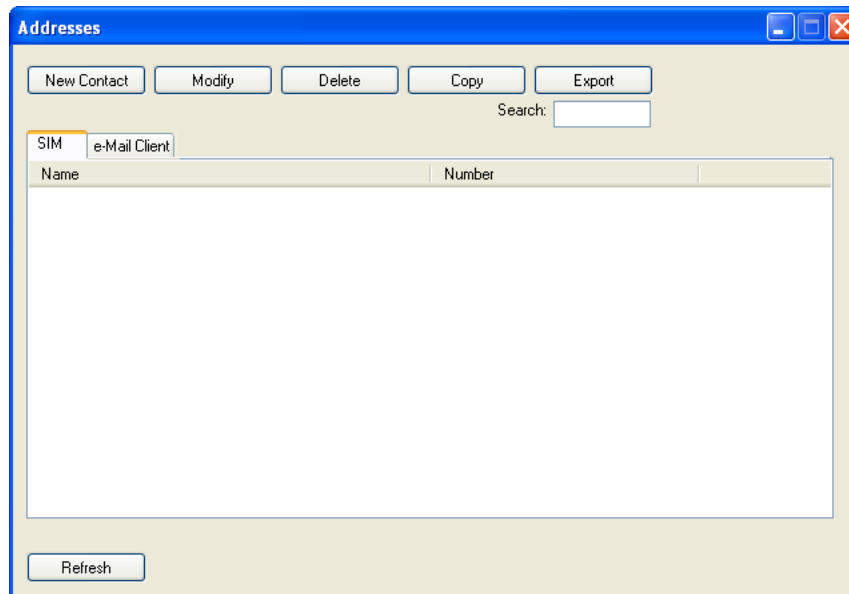

Web Browser

Clicking this button opens the Web Browser and allows the user to surf the Internet once the connection is established. The default browser is used, which is Internet Explorer by default on the Thor VM1.

Email

Clicking this button opens the Email application after the connection is established. The Email application is the default Email client set in the Control Panel (**Start > Control Panel > Internet Options > Programs** tab).

GPS

Tap the GPS button to open the GPS window. Press **Get GPS** to start the GPS. The rotating GPS button indicates the GPS is active.



After Latitude and Longitude Data are displayed, the user can tap **Track Me** to open Google Maps, showing their current location on a map.

Lat - Latitude - The location north or south of the equator in degrees.

Lon - Longitude: The angular distance from the Prime Meridian in degrees.

After Latitude and Longitude Data are displayed, the user can tap **Clipboard** and the latitude and longitude are copied to the clipboard cache. The data can be pasted into an email, document or other electronic media.

About

OneClick Internet allows the user to configure the WWAN connection by entering basic setup information. The network connection (service carrier) can be chosen based on the firmware loaded, GPS tracking can be enabled and SMS messaging can be configured.

Once configured, OneClick Internet allows the user to connect or disconnect from the mobile network.

System Requirements

OneClick Internet requires:

- Gobi 2000 3G Module (preinstalled by Honeywell)
- Gobi 2000 Driver package (loaded by Honeywell)

OneClick Internet for Gobi 2000 is compatible with the following operating system on the Thor VM1:

- Windows Embedded Standard 2009

Supported Languages

OneClick Internet supports the following languages:

German, English, Spanish, French, Polish, Russian, Italian, Simplified Chinese and Traditional Chinese.

Note: This does not mean that the Thor VM1 has been localized for these languages.

Installing or Upgrading OneClick Internet

Note: You must use the Honeywell supplied version of OneClick Internet. Do not change versions unless instructed by your Honeywell representative.

One Click Internet is pre-installed before the Thor VM1 is shipped.

If you have an installed version of OneClick Internet and need to update to a newer version, you must uninstall the previous version first by selecting **Start > Control Panel** and select **Add or Remove Programs**. Select **OneClick Internet** and tap **Remove**. Follow the on screen instructions.

Note: OneClick Internet does not install the drivers for the Gobi 2000 devices. Device drivers are preloaded.

Installation

When you double-click the Installer file for OneClick Internet, it extracts the files to install.

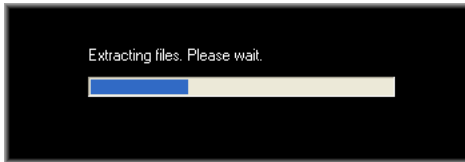

Next, select the application language. By default, the language of the OS is used (if available).

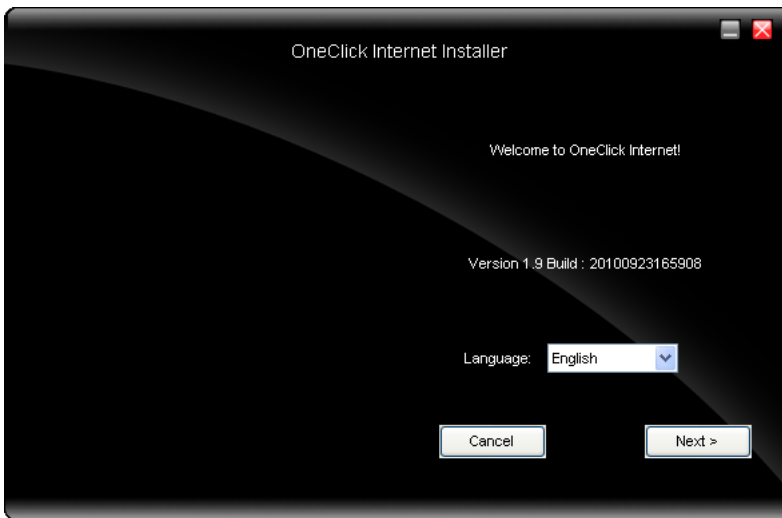

Review and accept the license agreement. Click **Accept**, if you agree. Otherwise please click **Reject** to cancel installation.

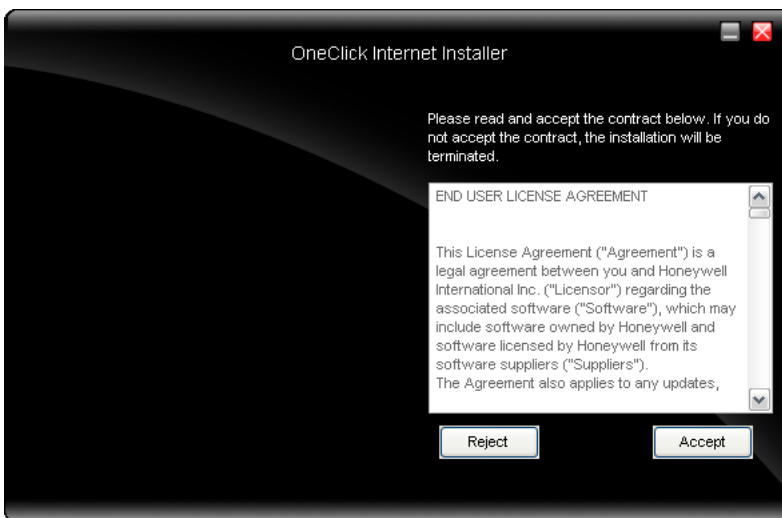

Next the installer asks for the installation directory. Use the **Browse** button to specify a location other than the default.



Installation process is indicated on screen. When completed, click the **Finish** button to exit the installer.



Start OneClick Internet from the Windows Program Menu or double-tap the desktop icon.

OneClick Internet Connection Manager

Launch OneClick Internet from the desktop icon or Windows Start Menu.

When OneClick Internet is active, a status icon appears in the system tray.











The main screen for OneClick Internet opens when the application is started. This screen displays basic information on the connection as well as access to more advanced features and details. From this screen you can connect to the Internet, send Emails, send short messages (SMS) and access the GPS.















General Windows controls for minimize and exit are located at the upper right of the screen.

Connection Management

Refer to the table below for descriptions of the items in the connection management area.

Icon	Description
	<p>Network signal strength Additionally the network name is displayed to the right of the icon. The more green bars, the stronger the signal.</p>
	<p>Connect / Cancel / Disconnect Tap this button to connect or disconnect. The color of this button also indicates the status of the connection:</p> <div style="display: flex; align-items: center; margin-bottom: 5px;">  <div style="margin-left: 5px;">The radio is disconnected. Tap the button to connect.</div> </div> <div style="display: flex; align-items: center; margin-bottom: 5px;">  <div style="margin-left: 5px;">The radio is currently connecting.</div> </div> <div style="display: flex; align-items: center;">  <div style="margin-left: 5px;">The radio is connected. Tap the button to disconnect.</div> </div>
	<p>SMS The SMS button is enabled if no Internet connection is active. When this button is active, tapping it accesses the integrated SMS application.</p>
	<p>Web Tap this button to launch the default browser.</p>
	<p>Email Tap this button to launch the default Email application.</p>
	<p>GPS Tap this button access the integrated GPS tool.</p>

Information Buttons

Icon	Description
	<p>Radio On/Off Tap this button to switch the radio state. The color of this button also indicates the state of the radio:</p> <p> The radio is On. Tap the button to turn the radio Off.</p> <p> The radio is Off. Tap the button to turn the radio On.</p> <p> The radio is Connecting or the radio has been disabled. The button is inactive at this time.</p>
	<p>Statistics Show/Hide</p> <p> Tap the button to expand the screen to include connection statistics. See Statistics Button (page 6-42) for details.</p> <p> Tap the button to hide the connection statistics.</p>
	<p>Settings Tap this button to access One Click Internet settings..Select from several tabs to configure the connection settings. See Settings Button (page 6-43) for details.</p>
	<p>Update Tap this button to access OneClick Internet update tab. See Update Button (page 6-42).</p>
	<p>Help Click this button to view the online help.</p>
Status	<p> Ready. Tap the Connect button to establish a connection.</p> <p> Connecting. Tap the Cancel button to cancel the connection in process.</p> <p> Connected. Tap the Disconnect button to end the connection.</p> <p> Failure. Review the screen for messages such as “No Network”, etc.</p>

Key Maps

64-Key QWERTY Keypad Key Map

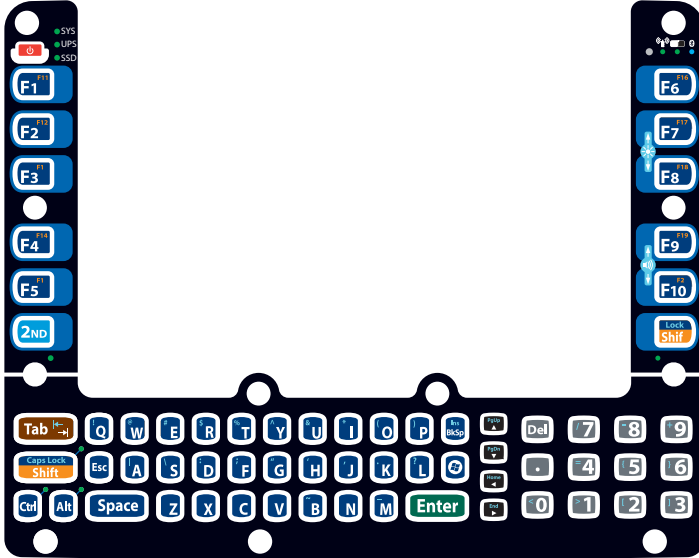

- Because the keyboard only has 64 keys, all functions are not visible (or printed on the keyboard). Therefore the Thor VM1 keyboard supports what is called hidden keys -- keys that are accessible but not visible on the keyboard.
- The keyboard does not have a NumLock indicator or key. NumLock is always On.

Note: When automatic brightness control is enabled for a Thor VM1 with an Outdoor display, the manual display brightness controls in the table below have no effect.

To get this Key / Function	Press These Keys in this Order	
Power On/Suspend	Power	
2nd mode	2nd	
Volume Up	2nd	F9
Volume Down	2nd	F10
Display Backlight Brightness Up	2nd	F7 (see note above)
Display Backlight Brightness Down	2nd	F8 (see note above)
Shift	Shift	
Alt	Alt	
Ctrl	Ctrl	
Esc	Esc	
Space	Space	
CapsLock	2nd	Shift
Enter	Enter	
Delete	Del	
. (VK_DECIMAL)	.	
Back Space	BkSp	
Insert	2nd	BkSp
Tab	Tab	
Back Tab	2nd Tab	

To get this Key / Function	Press These Keys in this Order	
Ctrl-Break		
Pause		
Up Arrow	Up Arrow	
Down Arrow	Down Arrow	
Right Arrow	Right Arrow	
Left Arrow	Left Arrow	
Page Up	2nd	Up Arrow
Page Down	2nd	Down Arrow
End	2nd	Right Arrow
Home	2nd	Left Arrow
F1 - F10	F1 - F10	
F11 - F20	Shift	F1 - F10
a	A	
b	B	
c	C	
d	D	
e	E	
f	F	
g	G	
h	H	
i	I	
j	J	
k	K	
l	L	
m	M	
n	N	
o	O	
p	P	
q	Q	
r	R	
s	S	
t	T	
u	U	
v	V	
w	W	
x	X	
y	Y	
z	Z	
A	Shift	A
B	Shift	B
C	Shift	C

To get this Key / Function	Press These Keys in this Order	
D	Shift	D
E	Shift	E
F	Shift	F
G	Shift	G
H	Shift	H
I	Shift	I
J	Shift	J
K	Shift	K
L	Shift	L
M	Shift	M
N	Shift	N
O	Shift	O
P	Shift	P
Q	Shift	Q
R	Shift	R
S	Shift	S
T	Shift	T
U	Shift	U
V	Shift	V
W	Shift	W
X	Shift	X
Y	Shift	Y
Z	Shift	Z
	2nd	A
~	2nd	B
:	2nd	D
#	2nd	E
;	2nd	F
"	2nd	G
'	2nd	H
*	2nd	I
,	2nd	J
. (VK_PERIOD)	2nd	K
?	2nd	L
_	2nd	M
`	2nd	N
(2nd	O
)	2nd	P
!	2nd	Q
\$	2nd	R
\	2nd	S

To get this Key / Function	Press These Keys in this Order	
%	2nd	T
&	2nd	U
@	2nd	W
^	2nd	Y
1	1	
2	2	
3	3	
4	4	
5	5	
6	6	
7	7	
8	8	
9	9	
0	0	
>	2nd	1
[2nd	2
]	2nd	3
=	2nd	4
{	2nd	5
}	2nd	6
/	2nd	7
-	2nd	8
+	2nd	9
<	2nd	0
!	Shift	1
@	Shift	2
#	Shift	3
\$	Shift	4
%	Shift	5
^	Shift	6
&	Shift	7
*	Shift	8
(Shift	9
)	Shift	0

IBM Terminal Emulation

The Thor VM1 IBM 3270 and IBM 5250 Terminal Emulator keypads are designed to allow the user to enter terminal emulator commands when running the RFTerm program. When running RFTerm on the Thor VM1, please refer to the *RFTerm Reference Guide* for equivalent keys and keypress sequences.

IBM 3270



Legend on Keypad	Explanation	Key Sequence
Attn	Attention	Ctrl + A
Clr	Clear	Ctrl + C
Del	Delete	Ctrl + D
E-Inp	Erase Input	Ctrl + BkSp
Ins	Insert	Ctrl + I
NL	New Line	Ctrl + N
PA1		Ctrl + F1
PA2		Ctrl + F2
PA3		Ctrl + F3
Rst	Reset	Ctrl + R
SysReq	System	Ctrl + S

IBM 5250



Legend on Keypad	Explanation	Key Sequence
Attn	Attention	Ctrl + A
Clr	Clear	Ctrl + C
Del	Delete	Ctrl + D
Dup	Duplicate	Ctrl + U
E-Inp	Erase Input	Ctrl + Bksp
Field Exit	Enter	Enter
Fld -	Field Minus	Ctrl + M
Fld +	Field Plus	Ctrl + L
Ins	Insert	Ctrl + I
NL	New Line	Ctrl + N
SysReq	System	Ctrl + S

Specifications and Reference Material

Technical Specifications

Thor VM1

Processor	Atom CPU operating at 1.6 GHz
Memory	2 GB SDRAM
Mass Storage	4 or 8 GB CompactFlash memory card
Storage Expansion	User installable, supports 1 to 4GB SD card
Operating System	Microsoft Windows Embedded Standard 2009
Radio Modules	802.11 a/b/g/n radio / Bluetooth Optional GPS / WWAN
Scanner Options	No integrated scanner, Optional serial, USB or Bluetooth scanners
Display Technology	Intel GMA 500 graphics processor, WVGA compatible Active matrix TFT Resolution: 800 x 480 pixels 400 NIT (indoor) or 900 NIT (outdoor) brightness 8" (measured horizontally) display Transmissive with LED backlight Automatic brightness control on outdoor display Vehicle motion screen blanking available
Touch Screen	Impact resistive Signature capture capability Optional defroster Field replaceable front panel including touch screen and optional defroster
Keyboard	Integrated keyboard, 64-key QWERTY (optional 3270 or 5250 overlay)
External Connectors	Optional external 802.11 / GPS / WWAN antenna connectors Additional connectors on Quick Mount Smart Dock, see below
Beeper	Minimum loudness greater than 95dBm at 10 cm in front of unit
Power Supply	10 to 60 VDC isolated
Uninterruptible Power Supply	Internal UPS battery, field replaceable, 30-minute life at -20°C (-4°F)
Backup Battery (RCT)	Internal lithium battery maintains Real Time Clock

Quick Mount Smart Dock

External Connectors	Two external RS-232 serial ports, COM1 and COM2, with switchable power CANbus/Audio connector supports either audio/microphone via adapter cable or J1939 Female and J1939 Male connectors via CANbus cable USB connector supports USB host port via adapter cable
Power Connector	6-pin connector: Direct 10-60V DC input power Optional external converters for AC (90-240 VAC) and extended range DC (60-150 VDC)
Power Switch	Sealed power switch
External Power Supply	AC Adapter, 120-240VAC to 12VDC
Input Power	DC Input Voltage: 10- 60 VDC Input Current: 4.6 Amps Input Fuse: 10A Time Delay

Dimensions

Thor VM1

Width	10.6" (26.8 cm)
Height	8.4" (21.4 cm)
Depth	1.7" (4.3 cm)
Weight	5.6 lb. (2.5 kg)

Quick Mount Smart Dock

Note: The RAM ball is not included in the following measurements.

Length	7.1" (18.0 cm)
Width	6.1" (15.5 cm)
Height	2.5" (6.4 cm), measurement includes strain relief cable clamps
Weight	3.2 lb. (1.5 kg)

Environmental Specifications

Thor VM1 and Quick Mount Smart Dock

Operating Temperature	Standard: -4°F to 122°F (-20°C to 50°C) [non-condensing] Cold Storage: -22° to 122° F (-30°C to 50°C) [condensing]
Storage Temperature	Standard and Cold Storage: -22°F to 140°F (-30°C to 60°C) [non-condensing]
ESD	8 KV air, 4kV direct contact
Operating Humidity	Standard: Up to 90% non-condensing at 104°F (40°C) Cold Storage: 100%
Water and Dust	IEC 60529 compliant to IP66
ESD	15 kV
Vibration	MIL-STD-810F, composite wheeled vehicles.
Crash	SAE-J 1455

Network Card Specifications

Summit 802.11 a/b/g/n

Bus Interface	32-bit PCIe Mini Card
Wireless Frequencies (varies by regulatory domain)	2.4 to 2.4895 GHz IEEE 802.11b / 802.11g DSSS OFDM 5.15 to 5.82 GHz IEEE 802.11a DSSS OFDM
RF Data Rates	802.11a (OFDM) 6, 9, 12, 18, 24, 36, 48, 54 Mbps 802.11b (DSSS) 1, 2, 5.5, 11 Mbps 802.11g (OFDM) 6, 9, 12, 18, 24, 36, 48, 54 Mbps 802.11n (OFDM 20 MHz chs) 13, 26, 39, 52, 78, 104, 117, 130 Mbps 802.11n (OFDM 40 MHz chs) 27, 54, 81, 108, 162, 216, 243, 270 Mbps
RF Power Level	50 mW max.
Channels	FCC: 1-11, 36, 40, 44, 48, 149, 153, 157, 161 ETSI: 1-13, 36, 40, 44, 48
Connectivity	TCP/IP, Ethernet, ODI
Diversity	Yes

Bluetooth

Bus Interface	USB
Enhanced Data Rate	Up to 3.0 Mbit/s over the air
Connection	No less than 32.80 feet (10 meters) line of sight
Bluetooth Version	2.0 + EDR
Operating Frequency	2.402 - 2.480 GHz
QDID	B013455

WWAN

Device	Gobi™ 2000 (data only)
Technology	Five-band UMTS/HSPA+ (800/850/900/1900/2100MHz), quadband GSM/GPRS/EDGE (850/900/1800/1900MHz) and dual-band EV-DO/CDMA (800/1900)

Port and Connector Pinouts

Power Supply Connector

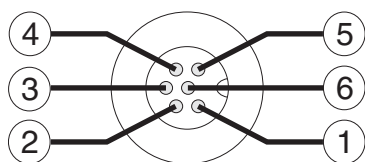

Pin	Signal	Description
1	V In+	10-60V DC input +
2	V In+	10-60V DC input +
3	V In-	input -
4	V In-	input -
5	GND	Chassis ground
6	Ignition	+0V to 60V to start terminal

COM1 and COM2 Connector

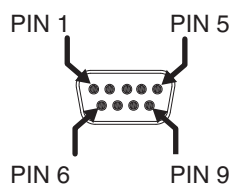

Pin	Signal	Description
1	DCD	Data Carrier Detect – Input
2	RXD	Receive Data – Input
3	TXD	Transmit Data – Output
4	DTR	Data Terminal Ready – Output
5	GND	Signal/Power Ground
6	DSR	Data Set Ready – Input
7	RTS	Request to Send – Output
8	CTS	Clear to Send – Input
9	+5VDC	Bar Code Scanner Power - 500mA max
Shell	CGND	Chassis Ground

USB Connector

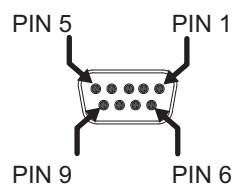

Pin	Signal	Description
1	GND	Common ground
2	USBC_D+	USB client data signal (not used)
3	USBC_D-	USB client data signal (not used)
4	USB_H1_PWR	USB host 1; 5V output power
5	GND	Common ground
6	GND	Common ground
7	USB_H1_D+	USB host 1 data signal
8	USB_H1_D-	USB host 1 data signal
9	USBC_VBUS	USB client 5V detect from attached host (not used)

USB Y Cable

D9 Male Connector

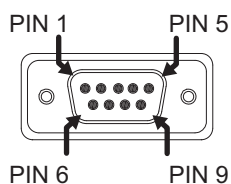

Pin	Signal	Description
1	GND	Common ground
2	USBC_D+	USB client data signal
3	USBC_D-	USB client data signal
4	USB_H1_PWR	USB host 5V output power
5	GND	Common ground
6	GND	Common ground
7	USB_H1_D+	USB host 1 data signal
8	USB_H1_D-	USB host 1 data signal
9	USBC_VBUS	USB client 5V detect from attached host

USB Host Connector

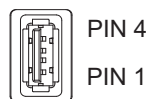

Pin	Signal	Description
1	5V_USB	USB Power, Current Limited
2	USB_H1_D-	USB D-
3	USB_H1_D+	USB D+
4	GND	USB Power Return
Shell	CGND	Chassis Ground

USB Client Connector

The USB client connection is not supported on the Thor VM1 with the Windows Embedded Standard operating system.

CANbus / Audio Connector

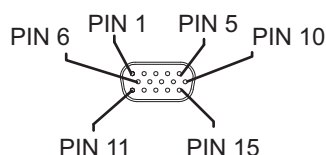

Pin	Signal Name	Description
1	-	CAN reserved
2	CAN_L	CAN_L bus line dominant low
3	CAN_GND	CAN Ground
4	-	CAN reserved
5	GND	Optional ground
6	Audio return	Headset return
7	Audio output	Headset output
8	Mic input	Microphone input
9	Mic return	Microphone return
10	Audio Return	
11	GND	Optional ground
12	CAN_SHLD	
13	CAN_H	CAN_H bus line dominant high
14	-	CAN reserved
15	CAN_V+	Option CAN external Power Supply

Headset Adapter Cable

D15 Female Connector

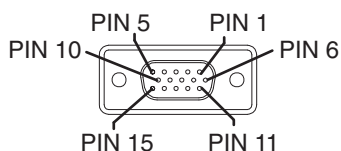

Pin	Signal	Description
1	Not used	
2	Not used	
3	Not used	
4	Not used	
5	Not used	
6	Audio return	Headset return
7	Audio output	Headset output
8	Mic input	Microphone input
9	Mic return	Microphone return
10	Not used	
11	Not used	
12	Not used	
13	Not used	
14	Not used	
15	Not used	

Quick Connect Headset Connector

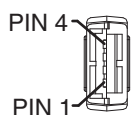

Pin	Signal	Description
1	Mic input	Microphone input
2	Mic return	Microphone return
3	Audio output	Headset output
4	Audio return	Headset return

CANbus Y Cable
D15 Female Connector

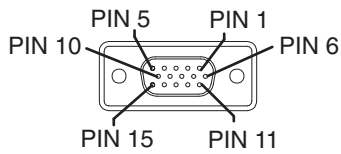

Pin	Signal	Description
1	Not Used	
2	CAN_L	CAN_L bus line dominant low
3	CAN_GND	CAN ground
4	Not Used	CAN reserved
5	GND	Ground
6	Not used	
7	Not used	
8	Not used	
9	Not used	
10	Not used	
11	GND	Optional ground
12	CAN_SHLD	
13	CAN_H	CAN_H bus line dominant high
14	Not Used	CAN reserved
15	CAN_V+	CAN external power supply

9-Pin J1939 (Deutsch) Connectors

Receptacle-
J1939 Female

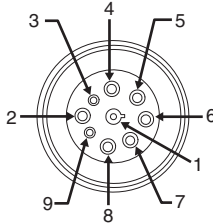

Socket
J1939 Mail

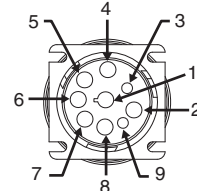

Pin	Signal	Description
1	CAN_GND	CAN Ground
2	CAN_V+	Option CAN external Power Supply
3	CAN_H	CAN_H bus line dominant high
4	CAN_L	CAN_L bus line dominant low
5	CAN_SHLD	
6	Not used	
7	Not used	
8	Not used	
9	Not used	

Hat Encoding

Desired ASCII	Hex Value	Hat Encoded
NUL	0X00	^@
SOH	0X01	^A
STX	0X02	^B
ETX	0X03	^C
EOT	0X04	^D
ENQ	0X05	^E
ACK	0X06	^F
BEL	0X07	^G
BS	0X08	^H
HT	0X09	^I
LF	0X0A	^J
VT	0X0B	^K
FF	0X0C	^L
CR	0X0D	^M
SO	0X0E	^N
SI	0X0F	^O
DLE	0X10	^P
DC1 (XON)	0X11	^Q
DC2	0X12	^R
DC3 (XOFF)	0X13	^S
DC4	0X14	^T
NAK	0X15	^U
SYN	0X16	^V
ETB	0X17	^W
CAN	0X18	^X
EM	0X19	^Y
SUB	0X1A	^Z
ESC	0X1B	^[
FS	0X1C	^\\
GS	0X1D	^]
RS	0X1E	^^
US	0X1F	^ (Underscore)
	0X7F	^?
	80	~^@
	81	~^A
	82	~^B
	83	~^C
IND	84	~^D
NEL	85	~^E
SSA	86	~^F
@	AE	~. (Period)
-	AF	~/
°	B0	~0 (Zero)
±	B1	~1

Desired ASCII	Hex Value	Hat Encoded
ESA	87	~^G
HTS	88	~^H
HTJ	89	~^I
VTS	8A	~^J
PLD	8B	~^K
PLU	8C	~^L
RI	8D	~^M
SS2	8E	~^N
SS3	8F	~^O
DCS	90	~^P
PU1	91	~^Q
PU2	92	~^R
STS	93	~^S
CCH	94	~^T
MW	95	~^U
SPA	96	~^V
EPA	97	~^W
	98	~^X
	99	~^Y
	9A	~^Z
CSI	9B	~^[
ST	9C	~^\\
OSC	9D	~^]
PM	9E	~^^
APC	9F	~^ (Underscore)
(no-break space)	A0	~ (Tilde and Space)
¡	A1	~!
¢	A2	~"
£	A3	~#
¤	A4	~\$
¥	A5	~%
¦	A6	~&
§	A7	~'
¨	A8	~(
©	A9	~)
ª	AA	~*
«	AB	~+
¬	AC	~,
(soft hyphen)	AD	~ (Dash)
×	D7	~W
Ø	D8	~X
Ù	D9	~Y
Û	DA	~Z

Desired ASCII	Hex Value	Hat Encoded
z	B2	~2
3	B3	~3
.	B4	~4
µ	B5	~5
¶	B6	~6
.	B7	~7
,	B8	~8
!	B9	~9
°	BA	~.
»	BB	~;
¼	BC	~<
½	BD	~=
¾	BE	~>
¿	BF	~?
À	C0	~@
Á	C1	~A
Â	C2	~B
Ã	C3	~C
Ä	C4	~D
Å	C5	~E
Æ	C6	~F
Ç	C7	~G
È	C8	~H
É	C9	~I
Ê	CA	~J
Ë	CB	~K
Ì	CC	~L
Í	CD	~M
Î	CE	~N
Ï	CF	~O
Ð	D0	~P
Ñ	D1	~Q
Ò	D2	~R
Ó	D3	~S
Ô	D4	~T
Õ	D5	~U
Ö	D6	~V

Desired ASCII	Hex Value	Hat Encoded
Û	DB	~[
Ü	DC	~\
Ý	DD	~]
Þ	DE	~^
ß	DF	~_ (Underscore)
à	E0	~`
á	E1	~a
â	E2	~b
ã	E3	~c
ä	E4	~d
å	E5	~e
æ	E6	~f
ç	E7	~g
è	E8	~h
é	E9	~i
ê	EA	~j
ë	EB	~k
ì	EC	~l
í	ED	~m
î	EE	~n
ï	EF	~o
ð	F0	~p
ñ	F1	~q
ò	F2	~r
ó	F3	~s
ô	F4	~t
õ	F5	~u
ö	F6	~v
÷	F7	~w
ø	F8	~x
ù	F9	~y
ú	FA	~z
û	FB	~{
ü	FC	~
ý	FD	~}
þ	FE	~~
ÿ	FF	~^?



Customer Support

Product Service and Repair

Honeywell International Inc. provides service for all of its products through service centers throughout the world. To obtain warranty or non-warranty service, please visit www.honeywellaidc.com and select **Support > Contact Service and Repair** to see your region's instructions on how to obtain a Return Material Authorization number (RMA #). You should do this prior to returning the product.

Technical Assistance

If you need assistance installing or troubleshooting your device, please contact us by using one of the methods below:

Knowledge Base: www.hsmknowledgebase.com

Our Knowledge Base provides thousands of immediate solutions. If the Knowledge Base cannot help, our Technical Support Portal (see below) provides an easy way to report your problem or ask your question.

Technical Support Portal: www.hsmsupportportal.com

The Technical Support Portal not only allows you to report your problem, but it also provides immediate solutions to your technical issues by searching our Knowledge Base. With the Portal, you can submit and track your questions online and send and receive attachments.

Web form: www.hsmcontactsupport.com

You can contact our technical support team directly by filling out our online support form. Enter your contact details and the description of the question/problem.

Telephone: www.honeywellaidc.com/locations

For our latest contact information, please check our website at the link above.

Limited Warranty

Honeywell International Inc. ("HII") warrants its products to be free from defects in materials and workmanship and to conform to HII's published specifications applicable to the products purchased at the time of shipment. This warranty does not cover any HII product which is (i) improperly installed or used; (ii) damaged by accident or negligence, including failure to follow the proper maintenance, service, and cleaning schedule; or (iii) damaged as a result of (A) modification or alteration by the purchaser or other party, (B) excessive voltage or current supplied to or drawn from the interface connections, (C) static electricity or electrostatic discharge, (D) operation under conditions beyond the specified operating parameters, or (E) repair or service of the product by anyone other than HII or its authorized representatives.

This warranty shall extend from the time of shipment for the duration published by HII for the product at the time of purchase ("Warranty Period"). Any defective product must be returned (at purchaser's expense) during the Warranty Period to HII factory or authorized service center for inspection. No product will be accepted by HII without a Return Materials Authorization, which may be obtained by contacting HII. In the event that the product is returned to HII or its authorized service center within the Warranty Period and HII determines to its satisfaction that the product is defective due to defects in materials or workmanship, HII, at its sole option, will either repair or replace the product without charge, except for return shipping to HII.

EXCEPT AS MAY BE OTHERWISE PROVIDED BY APPLICABLE LAW, THE FOREGOING WARRANTY IS IN LIEU OF ALL OTHER COVENANTS OR WARRANTIES, EITHER EXPRESSED OR IMPLIED, ORAL OR WRITTEN, INCLUDING, WITHOUT LIMITATION, ANY IMPLIED WARRANTIES OF MERCHANTABILITY OR FITNESS FOR A PARTICULAR PURPOSE, OR NON-INFRINGEMENT.

HII'S RESPONSIBILITY AND PURCHASER'S EXCLUSIVE REMEDY UNDER THIS WARRANTY IS LIMITED TO THE REPAIR OR REPLACEMENT OF THE DEFECTIVE PRODUCT WITH NEW OR REFURBISHED PARTS. IN NO EVENT SHALL HII BE LIABLE FOR INDIRECT, INCIDENTAL, OR CONSEQUENTIAL DAMAGES, AND, IN NO EVENT, SHALL ANY LIABILITY OF HII ARISING IN CONNECTION WITH ANY PRODUCT SOLD HEREUNDER (WHETHER SUCH LIABILITY ARISES FROM A CLAIM BASED ON CONTRACT, WARRANTY, TORT, OR OTHERWISE) EXCEED THE ACTUAL AMOUNT PAID TO HII FOR THE PRODUCT. THESE LIMITATIONS ON LIABILITY SHALL REMAIN IN FULL FORCE AND EFFECT EVEN WHEN HII MAY HAVE BEEN ADVISED OF THE POSSIBILITY OF SUCH INJURIES, LOSSES, OR DAMAGES. SOME STATES, PROVINCES, OR COUNTRIES DO NOT ALLOW THE EXCLUSION OR LIMITATIONS OF INCIDENTAL OR CONSEQUENTIAL DAMAGES, SO THE ABOVE LIMITATION OR EXCLUSION MAY NOT APPLY TO YOU.

All provisions of this Limited Warranty are separate and severable, which means that if any provision is held invalid and unenforceable, such determination shall not affect the validity of enforceability of the other provisions hereof. Use of any peripherals not provided by the manufacturer may result in damage not covered by this warranty. This includes but is not limited to: cables, power supplies, cradles, and docking stations. HII extends these warranties only to the first end-users of the products. These warranties are non-transferable.

The duration of the limited warranty for the Thor VM1 is 1 year.

The duration of the limited warranty for the Thor VM1 Quick Mount Smart Dock is 1 year.

The duration of the limited warranty for the Thor VM1 Vehicle Mount Assembly is 1 year.

The duration of the limited warranty for the Thor VM1 internal UPS battery is 1 year.

The duration of the limited warranty for the Thor VM1 AC power supply and cables is 1 year.

The duration of the limited warranty for the Thor VM1 DC/DC power supply is 1 year.

The duration of the limited warranty for the Thor VM1 cables (USB, Serial, Communication, Power) is 1 year.

The duration of the limited warranty for the Thor VM1 headset is 1 year.

Honeywell Scanning & Mobility
9680 Old Bailes Road
Fort Mill, SC 29707

www.honeywellaidc.com