

# PX940

High Performance Industrial Printer



---

## User Guide

---

# Disclaimer

Honeywell International Inc. (“HII”) reserves the right to make changes in specifications and other information contained in this document without prior notice, and the reader should in all cases consult HII to determine whether any such changes have been made. The information in this publication does not represent a commitment on the part of HII.

HII shall not be liable for technical or editorial errors or omissions contained herein; nor for incidental or consequential damages resulting from the furnishing, performance, or use of this material. HII disclaims all responsibility for the selection and use of software and/or hardware to achieve intended results.

This document contains proprietary information that is protected by copyright. All rights are reserved. No part of this document may be photocopied, reproduced, or translated into another language without the prior written consent of HII.

Copyright © 2019 Honeywell International Inc. All rights reserved.

Web Address: [www.honeywellaidc.com](http://www.honeywellaidc.com)

Microsoft® Windows®, Windows NT®, Windows 2000, Windows ME, Windows XP, and the Windows logo are trademarks or registered trademarks of Microsoft Corporation.

Apple is a trademark of Apple Inc., registered in the U.S. and other countries.

Zebra is a trademark or registered trademark of Zebra Corporation.

Other product names or marks mentioned in this document may be trademarks or registered trademarks of other companies and are the property of their respective owners.

For patent information, refer to [www.hsmpats.com](http://www.hsmpats.com).

# TABLE OF CONTENTS

Customer Support .....	ix
Technical Assistance .....	ix
Product Service and Repair .....	ix
Limited Warranty .....	ix
<b>Chapter 1 - Get Started .....</b>	<b>1</b>
Features .....	1
Full Touch Display .....	1
Print Button.....	1
Ready Screen .....	2
Main Menu .....	3
Navigate the Main Menu .....	4
Wizards .....	4
Printing Wizard .....	5
Communications Wizard .....	5
Calibration Wizard.....	5
Printer Command Languages.....	6
Autosense .....	6
Fingerprint.....	6
Intermec Printer Language (IPL) .....	6
ZPL Simulator (ZSim).....	7
DPL Simulator (DSim) .....	7
Access the Printer Web Page .....	7
Set the Printer Command Language .....	7
From the Printer Web Page.....	7

From the Main Menu .....	8
<b>Chapter 2 - Set Up the Printer .....</b>	<b>9</b>
Power Up the Printer.....	9
Calibrate the Touch Screen.....	10
To calibrate the screen from the website:.....	10
About the Media .....	10
Load Media for Tear-Off Printing .....	10
Load Media for Rewind Printing .....	14
Load Media for Peel-Off Printing .....	15
Load Fanfold Media .....	16
About the Ribbon .....	16
Load Ribbon .....	17
Print a Test Label.....	18
Printhead Pressure and Toggle Position .....	19
Pressure Adjustment .....	19
Toggle Position Adjustment.....	19
<b>Chapter 3 - Connect the Printer .....</b>	<b>21</b>
Connect the Printer to Your PC .....	21
Connect the Printer Using a Serial Cable .....	21
Connect the Printer Using a USB Cable.....	21
Connect the Printer to Your Network .....	21
Connect the Printer to an Ethernet Network.....	22
.....	22
Configure Bluetooth Communications from the Web Page .....	23
Configure Bluetooth Communications from the Main Menu .....	23
Printer Drivers .....	23
Install Printer Drivers.....	24
Install Authentication Certificates .....	24
USB Host Port .....	25
Connect a USB Device.....	25
<b>Chapter 4 - Configure the Printer .....</b>	<b>27</b>
Printer Configuration Menus .....	27

Printing Menu .....	28
System Settings Menu .....	29
Verifier Menu .....	29
Alert Menu .....	30
Printer Configuration .....	30
Restrict Access to the Main Menu .....	30
Access the Printer Web Page .....	31
Printer Webpage User Name and Password .....	31
Configure the Printer from the Web Page .....	31
Configure the Printer with Honeywell PrintSet 5 .....	32
Configure the Printer with Programming Commands .....	32
Uploading from the Web Page .....	33
Uploading from a USB Storage Device .....	33
Change Background Image for the Ready Screen .....	34
Printer Profiles.....	35
Save a Printer Profile from the Web Page .....	35
Load a Printer Profile from the Web Page .....	35
Save a Printer Profile from the Main Menu.....	36
Load a Printer Profile from the Main Menu .....	36
Load a Printer Profile Using Programming Commands.....	36
Install a Configuration File from a USB Storage Device .....	37
Export a Configuration File to a USB Storage Device.....	37
Menu Shortcuts .....	38
Create Menu Shortcuts .....	38
Customize the Printer Web Page .....	39

## **Chapter 5 - About the Verifier .....** **41**

Setting up the Verifier.....	41
Webpage .....	42
Front Panel.....	42
Verifier License .....	42
Calibration .....	42
Verifier Calibration Card .....	42

Verifier Settings .....	43
Verification Type .....	43
Passing Grade.....	43
Aperture .....	43
Retries .....	44
Verification Failure Action .....	44
Save Failed Label Images .....	44
Void Pattern .....	44
Print Modes and Speed.....	44
Barcode Symbolologies Supported .....	45
Barcode Orientations.....	45
Barcode Size Supported .....	45
Verification Length.....	45
Maximum Number of Barcodes per Label.....	45
Printing Behavior after Error Recovery.....	46
Printing Behavior after Recovered from error above: .....	46
Printing Errors .....	47
Unsupported Barcode Behavior .....	48
Example:.....	48
Verification Failed Error Handling.....	48
Failed Label Image File .....	49
USB Thumbdrive .....	49
Reporting and Statistics .....	50
Report Formats .....	51
Individual Report.....	51
Report Header .....	52
Barcode Information .....	53
All Supported 1D Barcodes Overall Parameters.....	54
2D Barcode, Datamatrix Overall Parameters .....	55
1D barcode 10 line Profile Grading Parameters.....	57
Summary Report .....	58
Restore Default Verification Files .....	58
Fingerprint Command.....	59

## **Chapter 6 - Troubleshooting.....61**

System Information.....	61
Statistics.....	61
Printer Odometer .....	62
Maintenance Alerts .....	62
Set Alerts .....	62
Alert Notifications .....	63
Error Alerts and Solutions .....	64
Verifier Error Alerts and Solutions .....	65
Troubleshoot Printer Problems and Find Solutions.....	65
Print Quality Problems .....	65
Verifier Problems .....	67
Networking Problems .....	68
Restore Printer Defaults .....	68
Restore Defaults from the Printer Web Page.....	68
Restore Defaults from the Main Menu .....	69
Restore Defaults with a Hardware-Based Reset .....	69
Upgrade the Printer Firmware .....	69
Upgrade Firmware from the Printer Web Page.....	70
Upgrade Firmware from a USB Storage Device .....	70

## **Chapter 7 - Maintenance .....71**

Clean the Printer.....	71
Clean the Printhead.....	71
Clean the Front Sensor (PX940A) .....	72
Clean the Verifier (PX940V).....	72
Clean the Media Path.....	73
Clean the Exterior of the Printer .....	73
Replace the Printhead.....	73
Replace the Platen Roller.....	74
Printhead Pressure and Toggle Adjustment .....	75
Pressure Adjustment.....	75
Label Taken Sensor Calibration.....	76
Label Gap and Black Mark Sensor Adjustments .....	76

**Chapter 8 - Product Specifications..... 77**

- Printer and Environmental Specifications ..... 77
- Supported Command Languages ..... 77
- Media Sensors ..... 77
- Network Services..... 78
- Fonts ..... 78
  - Resident Fonts..... 78
  - Downloadable Fonts ..... 80
  - Supported Font Types ..... 80
  - Bar Code Symbolologies ..... 81
    - 1D Bar Code Symbolologies..... 81
    - 2D Bar Code Symbolologies..... 81
  - Graphic File Types..... 82

**Appendix A - Default Settings..... 83**

- Communications Settings ..... 83
  - Serial Port..... 83
  - Ethernet ..... 84
- Bluetooth Settings ..... 84
- Media Settings ..... 85
- Print Quality Settings ..... 87
- System Settings..... 88
  - General System ..... 88
  - Display and Audio Settings ..... 89
  - System I/O ..... 89
  - System Network Services ..... 90
  - Verifier Settings..... 91



Verification Type .....	91
Passing Grade .....	92
Aperture .....	93
Retries .....	94
Verification Failure Action .....	95
Save Failed Label Images .....	96
Void Pattern .....	96
Maintenance Alerts.....	97
<b>Appendix B - Print Labels with INPrint.....</b>	<b>99</b>
The INPrint Page .....	99
Print INPrint Labels .....	99
<b>Appendix C - Accessory Installation Instructions.....</b>	<b>101</b>
Verifier Calibration Card.....	101
Handling Instructions.....	101



# Customer Support

## Technical Assistance

To search our knowledge base for a solution or to log in to the Technical Support portal and report a problem, go to [www.hsmcontactsupport.com](http://www.hsmcontactsupport.com).

For our latest contact information, see [www.honeywellaidc.com/locations](http://www.honeywellaidc.com/locations).

## Product Service and Repair

Honeywell International Inc. provides service for all of its products through service centers throughout the world. To obtain warranty or non-warranty service, return your product to Honeywell (postage paid) with a copy of the dated purchase record. To learn more, go to [www.honeywellaidc.com](http://www.honeywellaidc.com) and select **Service & Repair** at the bottom of the page.

## Limited Warranty

For warranty information, go to [www.honeywellaidc.com](http://www.honeywellaidc.com) and click **Get Resources > Product Warranty**.



# GET STARTED

The PX940 series industrial printer includes both PX940 productivity version (PX940A) and PX940 Verifier version (PX940V) with integrated barcode verification module.

Both PX940A and PX940V printers are rugged label printers that include integrated USB, RS-232, and Ethernet interfaces. You can connect the printers to a single PC, a wired network, or a wireless network.

## Features

- Print speed of up to 14 ips.
- USB host port for connecting storage devices, scanners, or keyboards.
- USB device port to connect to a PC.
- Support for printer programming languages including Fingerprint (FP), Direct Protocol (DP), Intermec Printer Language (IPL), Zebra Printer Language (ZPL), and Datamax Printer Language (DPL).

## Full Touch Display

The front panel has a 3.5 inch full-touch screen that supports touch input with fingers, gloved hands, or a stylus.

## Print Button



Use the **Print** button to feed media, pause print jobs, and print.

Printer State	Print Button Action
Startup	Press the <b>Print</b> button during startup to enter Calibration mode or to restore defaults if the printhead is lifted.
Ready	Press the <b>Print</b> button to advance the media.
	If the print key feature is on, press the <b>Print</b> button to reprint the last job.
	Press and hold the <b>Print</b> button to calibrate the media sensors.
Printing	Press the <b>Print</b> button to stop or pause printing. The printer stops after completing the current label.
Paused	Press the <b>Print</b> button to resume printing.
Error	Press the <b>Print</b> button to advance the media.

## Ready Screen

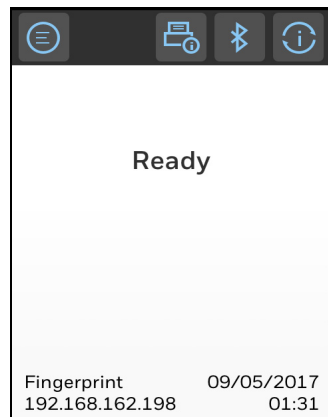





The Ready Screen appears when the printer is powered on and has completed its startup process.

**Note:** *The icon for WiFi status appears only when the optional WiFi module is installed.*

By default, the information bar at the bottom of the screen shows the printer command language and the printer IP address. You will see the time and current date only if the real time clock (RTC) is installed. You can customize the screen to show different types of information.

The status bar at the top of the screen includes these icons:

Icon	Name	Description
	Main Menu	Press the icon to view the main menu for your printer.
	Communications	Press the icon to view communications information for your printer.
	Printing	Press the icon to view specific printer information.
	Bluetooth	Press the icon to view Bluetooth information for your printer.
	Back	Press this icon to navigate back through the printer menus.

## Main Menu

On the printer Ready screen, press  to view the Main Menu.

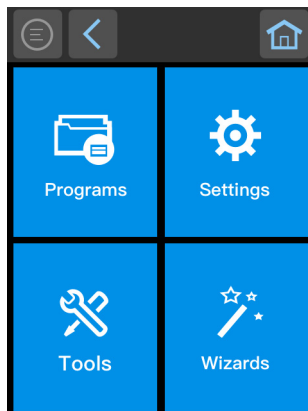

**Note:** If you create menu shortcuts, the Main Menu is replaced by the Quick Choices menu.









Press a button to select the **Programs**, **Settings**, **Tools**, or **Wizards** menu.

- **Programs** displays a list of programs installed on the printer. This list includes utility programs provided as part of the firmware and programs you have installed. **Programs** appears in the Main Menu only if the printer is using Fingerprint or Direct Protocol as the command language.
- Select **Settings** to view and change printer settings.
- Select **Tools** to print test labels, manage a connected USB storage device, restore printer default settings, or save and load printer profiles.
- Select **Wizards** to see a list of wizards that help you configure printing or communication settings, or calibrate the media sensors.

**Note:** The printer cannot print while the Main Menu is showing. Exit the Main Menu and return to the Ready screen to begin printing.

# Navigate the Main Menu

Use the status bar buttons to navigate between menus in the Main menu and save changes.

Button	Description
	Returns to the Main menu
	Goes back one level in the menu
	Returns to the Ready screen
	Moves between options in a settings menu
	Moves to additional options not viewable in the menu
	Bluetooth: Gives the device name and device address
	Information: Gives Communications information such as ethernet, serial, and usb
	Printer Information

**Note:** Use the horizontal scroll bar for settings with additional options.

# Wizards

The full touch printer includes several wizards you can use to quickly set up your printer. You can start all of the wizards from the Main menu except for the startup wizard. The startup wizard appears the first time you turn on the printer and after the printer has been reset to the factory default state.

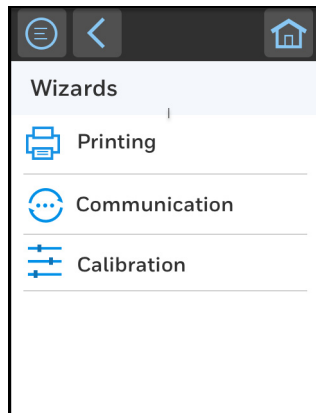



## Printing Wizard

Wizard	Description
Media Loading Guide	Shows how to load media.
Ribbon Loading Guide	(TTR printers only) Shows how to load ribbon.
Media Setup	Select media and printing type (DT or TTR), media width, length, and X-margin, Start and Stop Adjust values, and print speed.
Print Quality	Prints a series of labels to determine the best print quality setting.

## Communications Wizard

Wizard	Description
Line Analyzer	Logs all incoming data on all communications channels and saves the data to a log file. For experienced users.

## Calibration Wizard

Wizard	Description
Media	Calibrates all media sensors and shows current print settings.
Verifier	Calibrates the Verifier. (for PX940V only)
Label Taken Sensor	Calibrates the label taken sensor used with the label dispenser. Available when the label taken sensor is installed.
Date and Time	Calibrates the date and time.
Screen	Calibrates the touch screen.

# Printer Command Languages

A printer command language is a set of instructions that controls printer functions:

- Configure the printer.
- Return the status of the printer.
- Control peripheral devices.
- Format a label or receipt for printing.

The printer supports these command languages and language simulator support options:

- [Autosense](#)
- [Fingerprint](#)
- [Intermec Printer Language \(IPL\)](#)
- [ZPL Simulator \(ZSim\)](#)
- [DPL Simulator \(DSim\)](#)

## Autosense

Autosense allows the printer to automatically sense from label to label, the incoming data stream and its language, and print each label accordingly.

## Fingerprint

Fingerprint is a BASIC-inspired general purpose printer language. Use Fingerprint to design custom label formats and write printer application software. If you plan to run Smart Printing applications directly on the printer, without connecting to a PC, select Fingerprint as your printer command language. For more information, see the [Fingerprint Command Reference](#).

Fingerprint is the default printer command language.

## Intermec Printer Language (IPL)

IPL is a host-based printer command language. Use IPL to design, modify, and download label formats; write printer application software; and configure the printer. If you are sending IPL label files to the printer, select IPL as your printer command language. For more information, see the [IPL Command Reference](#).

**Note:** *IPL can be supported on 200dpi and 300dpi printer only*

## ZPL Simulator (ZSim)

ZSim (ZPL command language simulator) interprets Zebra™ programs (ZPL II or later) without requiring any host programming changes. If you are sending ZPL label files to the printer, select ZSim as your printer command language. For more information, see the [ZSim Command Reference](#).

## DPL Simulator (DSim)

DSim (DPL command language simulator) interprets Datamax™ data streams without requiring any host programming changes. If you are sending DPL label files to the printer, select DSim as your printer command language. For more information, see the [DSim Command Reference](#).

## Access the Printer Web Page

1. Open a browser window on your PC.
2. In the location or address bar, type the printer IP address and press **Enter**. The printer web page appears.
3. Click **Login**. The login page appears.

You will be prompted for a user name and password. The default username is **itadmin** and the default password is **pass**.

## Set the Printer Command Language

You can use one of these methods to change the printer command language:

- From the printer Web Page
- From the Main Menu
- PrintSet 5

### From the Printer Web Page

To set the command language from the printer web page, you need to turn on the printer and connect to your network.

1. Make sure that the printer has media and ribbon (if necessary) installed.
2. Open a browser window on your PC.
3. In the location or address bar, type the printer IP address and press **Enter**. The printer web page appears.
4. Click **Login**. The login page appears.

5. Type your **Username** and **Password** and click **Login**. The default username is **itadmin** and the default password is **pass**.
6. Click the **Configure** tab.
7. Click **System Settings > General**.
8. Select the printer command language you want to use from the Command Language list, and then click **Save**.
9. Click the **Services** tab.
10. Click **Reboot Printer**, and then click **Reboot**. The printer restarts in the command language you selected.

## From the Main Menu

You can use this procedure to change the printer command language from the Main Menu.

1. From the Ready screen, press the **Main Menu** button.
2. From the Main Menu, press **Settings > System Settings > General**.
3. Scroll down until you reach **Command Language**.
4. Select your desired command language.
5. Turn the printer off and then on. The printer starts up in the command language you selected.

# SET UP THE PRINTER

This section contains information about loading media and ribbon, printing a test label, calibrating the full touch screen, and adjusting the printer.

## Power Up the Printer

The full touch printer goes through a startup wizard the first time you turn on the power.

1. Connect one end of the power cord to the back of the printer and plug the other end to AC power.

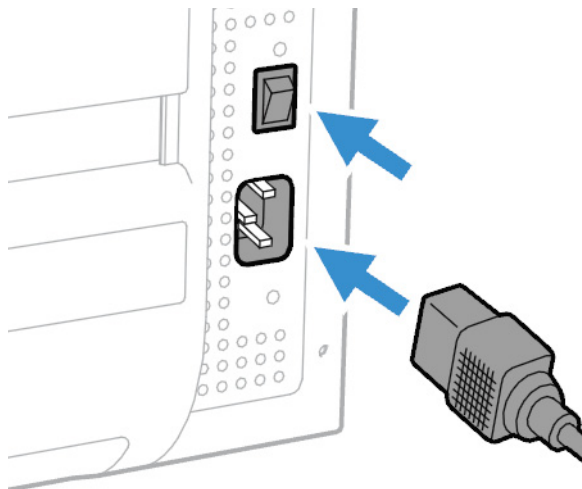

2. Press the power switch to turn on the printer.
3. As the printer starts up, a progress bar appears, then the startup wizard appears.
4. Follow the steps on the touch screen to complete the start up wizard.

# Calibrate the Touch Screen

You can calibrate the screen from the printer website or from the touch panel on the printer.

## To calibrate the screen from the website:

To access the website, make sure your printer is connected to the same network as your computer.

1. Open your browser and type the printer IP address into the web address bar.
2. In the menu section, click on **Services > Screen Calibration**. If you are prompted to login, the temporary username is **itadmin** and the password is **pass**.
3. Click on the blue **Screen Calibration** button, this will engage the touch panel to start screen calibration.
  - When the small square appears on the front touch panel of the printer, **touch the square** and continue to touch the square until the printer beeps.
4. Once calibration is complete, your touch screen will automatically return to the **Ready** screen.

**Note:** *Typical screen calibration consists of five touches (one in each corner and one in the middle of the screen)*

## About the Media

The printers can print on labels, tickets, tags, and continuous stock. The procedure you use to load media depends on how you are operating the printer and the options you have installed.

## Load Media for Tear-Off Printing

Tear-off printing is applicable to media with perforation. Printed labels, tickets, and other printed media are manually torn from the front of the printer. These of media can be used for tear-off printing:

- Non-adhesive continuous stock
- Self-adhesive continuous stock with liner
- Self-adhesive labels with liner
- Tickets with gaps, with or without perforations
- Tickets with black marks, with or without perforations

To load media for tear off printing:

1. Open the media cover and remove the rewind plate (if installed).
2. Turn the printhead lift lever counterclockwise to raise the printhead or verifier arm.

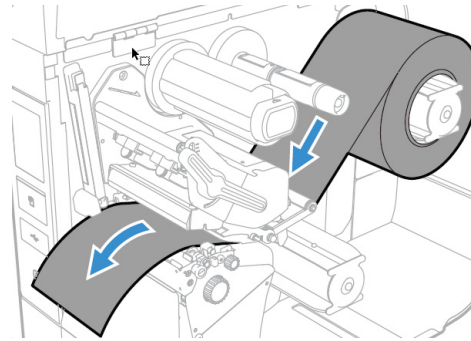
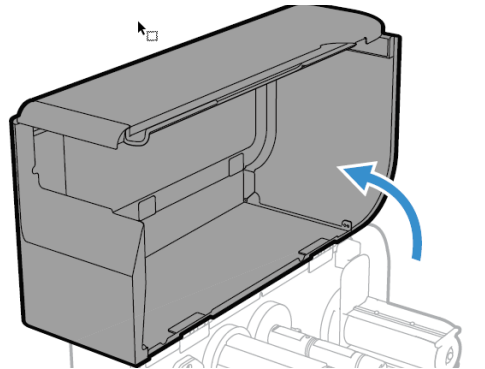

3.

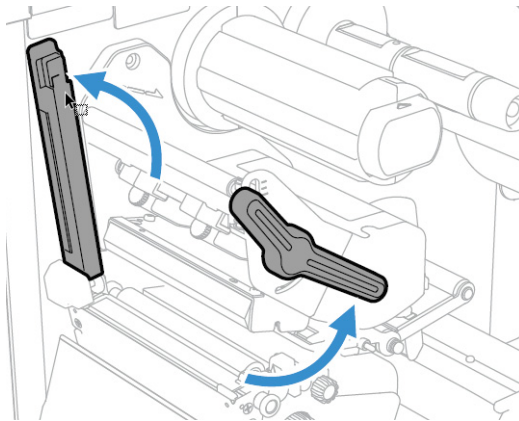

**print head arm lifted**

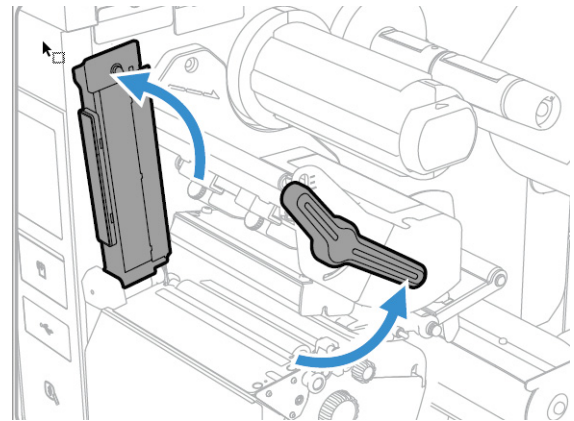

**verifier arm lifted**

4. Load a media roll onto the media supply hub. Make sure you push the roll all the way against the inner wall of the printer and adjust the edge guide and the dancer guide to hold the media in place.

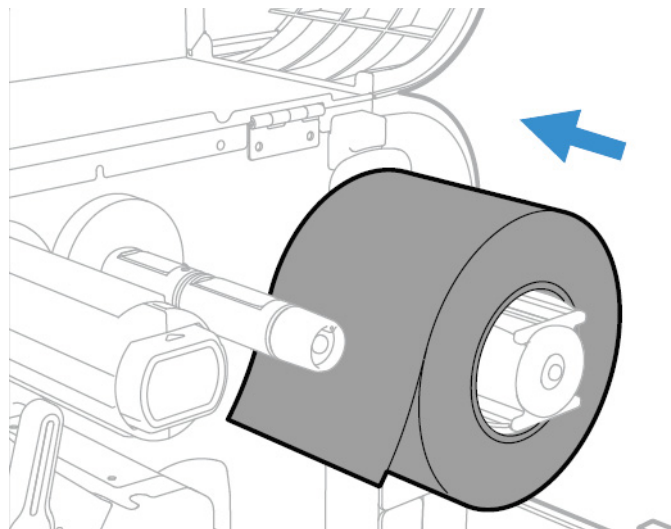

5. Route the media through the print mechanism, through the front sensor (PX940A) or verifier module (PX940V)

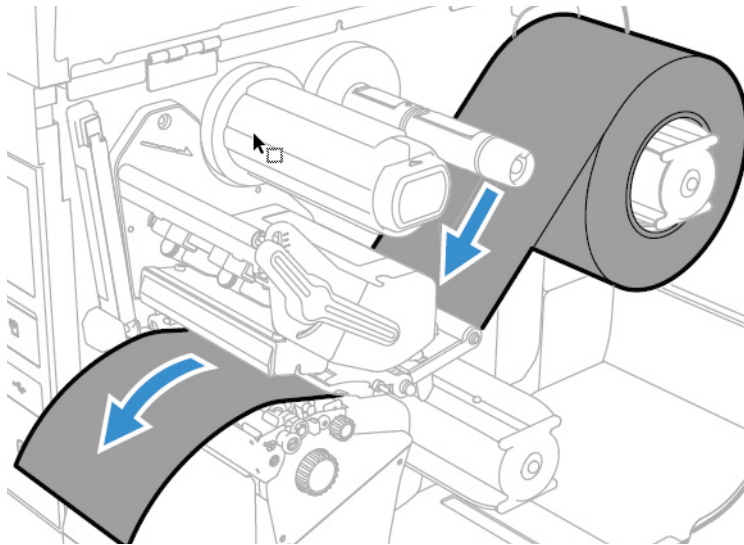

6. Adjust the media and dancer guides to hold the media in place.

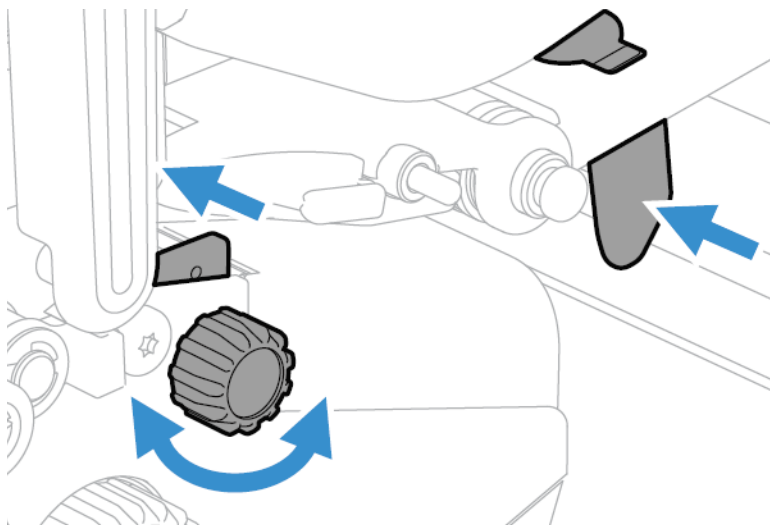

**Note:** There is a media guide that is located near the printhead. It is recommended to adjust the media guide all the way to the right in order to insert the media. If not, it can be difficult to load the media.



7. Turn the printhead lift lever clockwise to close the printhead and lower the front sensor/verifier arm and click into place.

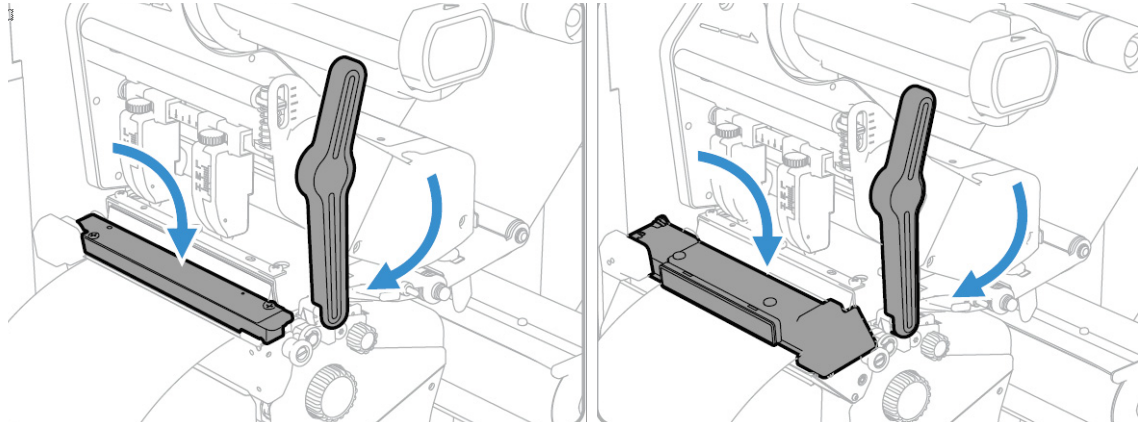

**print arm in place**

**verifier arm in place**

8. Press the **Print** button to advance the media.
9. Adjust the label gap and black mark sensor. The sensor blue LED should line up with the center of the media.
10. Close the media cover.

## Load Media for Rewind Printing

Follow steps 1-9 from Load Media for Tear-Off Printing, then:

1. Assemble the rewinder plate back to the printer.

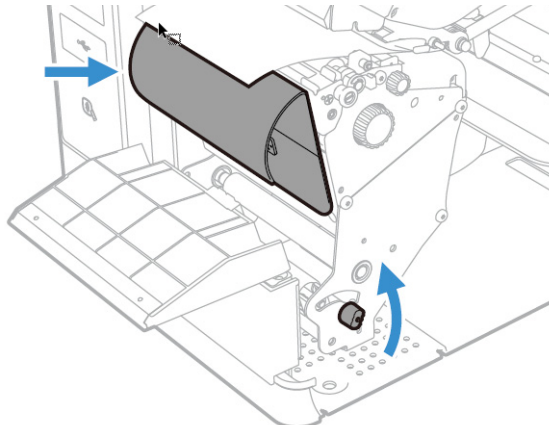

2. Round the media through the rewinder plate.

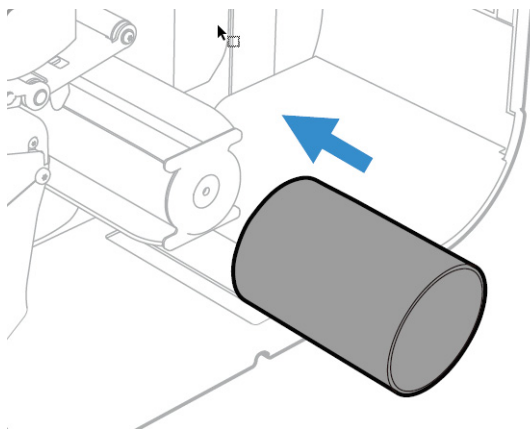

3. Insert the media in the opening between the label dispenser and the platen roller.

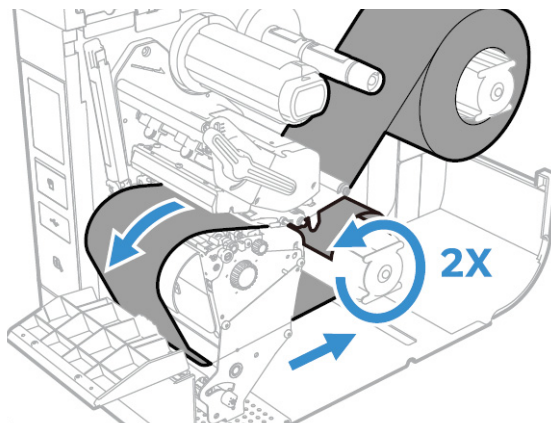

4. Route the media around the media rewriter.

5. Push the Rewind/Liner Take-Up knob into closed position.

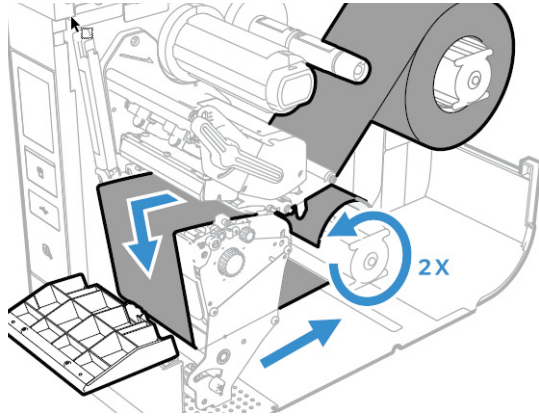

6. Put media roll holder in place
7. Go to **Main Menu > Setting > Printing > Media > Printing Mode**, select **Rewind** from the list

## Load Media for Peel-Off Printing

Follow steps 1-9 from Load Media for Tear-Off Printing, then:

1. Insert the media in the opening between the label dispenser and the platen roller.

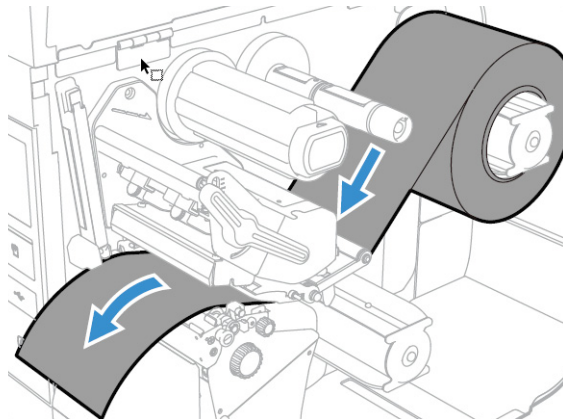

2. Round the liner around the media rewinder.

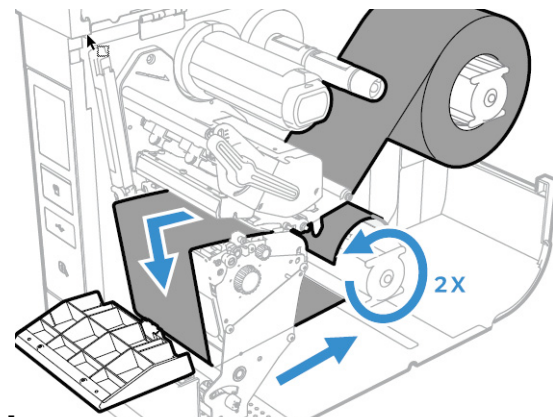

3. Pull the liner tight and push the Rewind/Liner Take-Up knob into closed position.
4. Put media roll holder in place.
5. Go to **Main Menu > Setting > Printing > Media > Printing Mode**, select **Peel-Off** from the list.

## Load Fanfold Media

To load Fanfold Media from behind the printer:

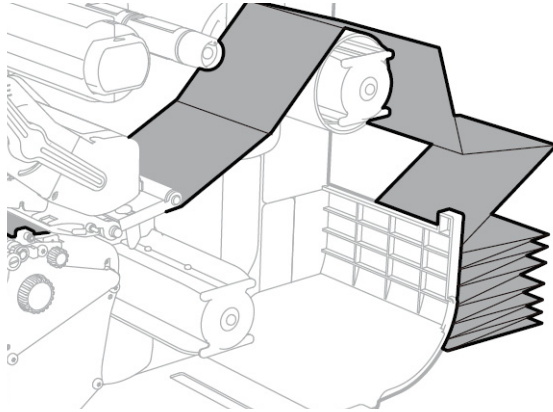

To load Fanfold media from bottom access slot:

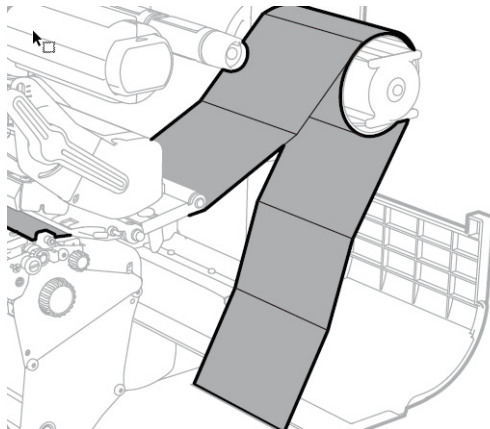

## About the Ribbon

Thermal transfer printing provides a durable printout that is less vulnerable to chemicals, heat, and sunlight than direct thermal printing. Select a ribbon type that matches the media you are using and configure the printer for thermal transfer media.

The printer supports thermal transfer ribbon rolls with the ink-coated side facing either inward or outward. To determine which type of ribbon you have, place the ribbon on a piece of paper as shown, and use a pen or other sharp object to scratch the ribbon. If you see a mark on the paper, your ribbon is wound ink out.

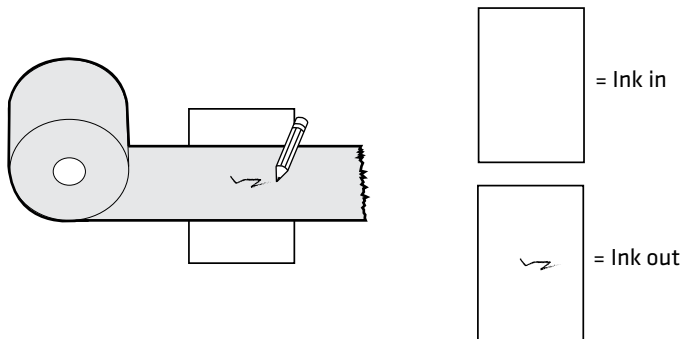

## Load Ribbon

1. Open the media cover.
2. Turn the printhead lift lever counterclockwise to raise the printhead.
3. Slide the ribbon roll onto the ribbon take-up hub.

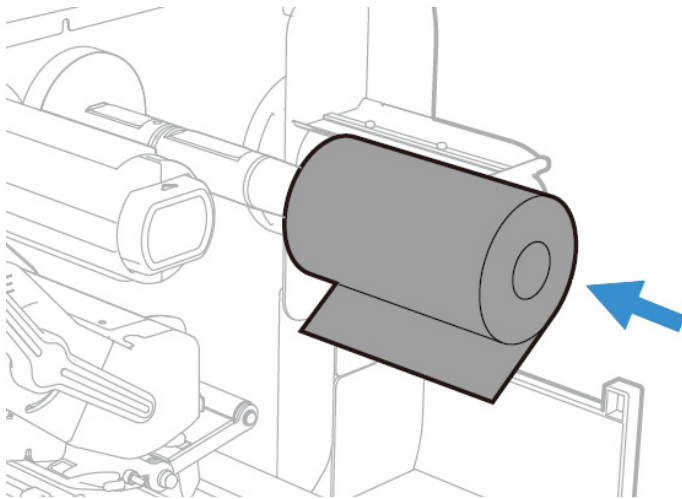

**Note:** For ribbon that has the ink wound out, place the ribbon on the supply hub with the ribbon wound clockwise. For ribbon that has the ink wound in, place the ribbon on the supply hub with the ribbon wound counterclockwise.

4. Route the ribbon through the print mechanism and pull out approximately 8 inches (20cm) of ribbon leader.

The dotted line in this illustration shows how to load ribbon with the ink wound in.

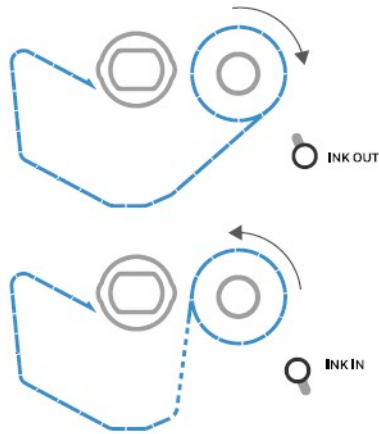

5. Turn the ribbon take-up hub counterclockwise until the ribbon becomes tight and runs wrinkle-free through the print mechanism.
6. Close the media cover.

## Print a Test Label

The first time you turn on the full touch printer or reset to factory defaults, the printer runs a startup wizard to let you enter basic setup information. After the startup wizard finishes, the printer enters Ready mode where you can access the Main Menu and print a test label.

1. Connect the printer to power and turn on the printer.
2. After the startup sequence finishes, the startup wizard begins. Enter all the information on the wizard screens then tap **No** when prompted to run other wizards.
3. From the Ready screen, press  to view the Main Menu.
4. From the Main Menu, tap **Tools > Test Labels**.
5. Select the test label you want to print and tap it.

Your test label prints. If print quality is low, go to **Wizards > Printing > Print Quality**.

**Note:** You can use command languages, like [Fingerprint](#), and language simulators, like [ZPL Simulator \(ZSim\)](#), to create and print labels. For more information, see the command reference manual for the language.

# Printhead Pressure and Toggle Position

## Pressure Adjustment

You may need to adjust the printhead pressure on the printer if:

- You are using thicker or thinner media than previously.
- Your thermal transfer ribbon starts to crease.

Do not use a higher printhead pressure than necessary. It may increase the wear on the printhead and shorten its life.

1. Use your finger to turn the wheel to adjust pressure.
  - Rotate the wheel clockwise to increase the pressure resulting in darker print.
  - Rotate the wheel counterclockwise to decrease the pressure resulting in lighter print.

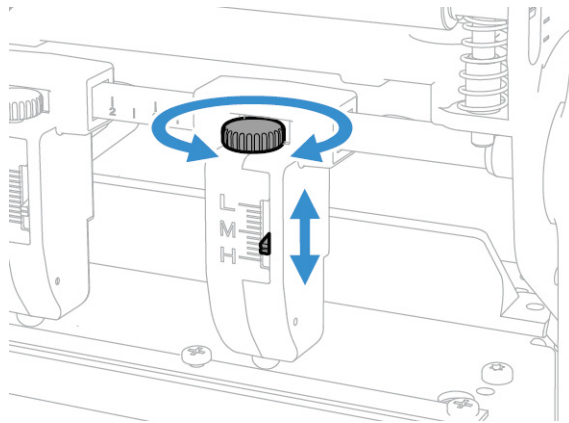

2. Test for Print Quality

**Note:** Marking on the toggle, “L”: Light pressure; “M”: Middle pressure; “H”: High pressure.

## Toggle Position Adjustment

If the toggles are not adjusted in the correct position or do not apply the correct pressure, the following issues may occur:

- Labels print lighter on one side than the other
- Media and ribbon may slip
- Ribbon may wrinkle
- Media may move from side to side during printing

You probably have an unbalanced printhead. The printer is adjusted at the factory for full-width media. If you are using media that is less than full-width (4 inches or 102mm), recommends that you adjust the position of the pressure toggles so that the printhead is correctly pressured against the media.

- Adjust the position of the toggle as necessary to provide the even pressure on the media.

**Note:** Especially for narrower media and narrower ribbon, position the inside toggle at the left of the media, and move to outside toggle to right side and decrease the pressure on it.

#### Narrow Media position

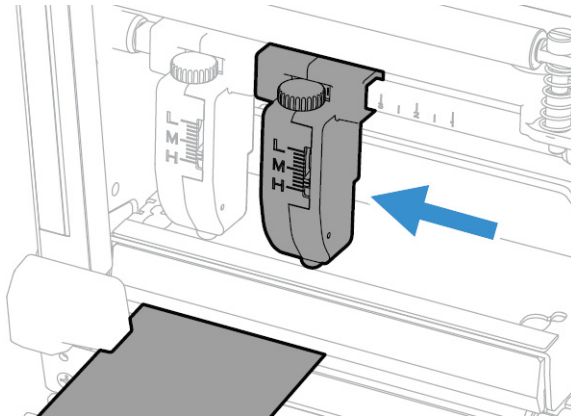

#### Wide Media position

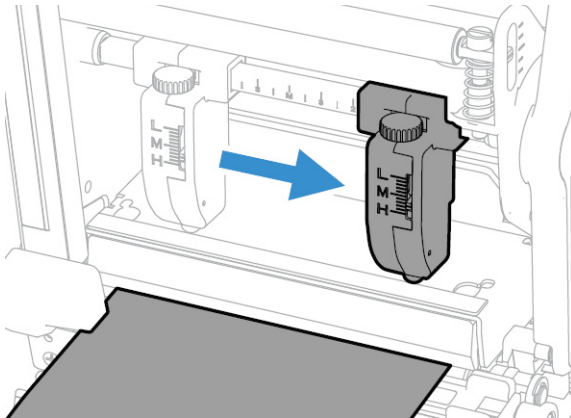



# CONNECT THE PRINTER

This section contains information about connecting the printer to a PC or to a network. Use the [From the Printer Web Page](#) or the Main Menu on a full touch printer to configure the settings.

## Connect the Printer to Your PC

You can connect the printer to your PC using one of the following methods.

### Connect the Printer Using a Serial Cable

You can use a serial connection to communicate with your PC and send commands directly to the printer through a terminal connection.

1. Connect one end of the DB9 to DB9 RS-232 cable to the back of your printer and connect the other end to a serial COM port on your PC.
2. If necessary, change the PC serial port configuration to match your printer.

### Connect the Printer Using a USB Cable

Connect only one printer to your PC, either directly or through a hub. You do not need to set up any parameters for USB communications.

1. Download and install the InterDriver software on your PC (see [Install Printer Drivers](#)).
2. When prompted, connect one end of the USB Type A cable to the back of the printer and connect the other end to your PC.

## Connect the Printer to Your Network

These network interfaces provide features such as security, FTP server, web page, and Alert handling.

# Connect the Printer to an Ethernet Network

Use the Ethernet port to set up your printer as a network printer. The printer is set to automatically retrieve an IP number from the network (DHCP) when you turn the printer. You can use the network connection with InterDriver. You can also use it to send commands directly to the printer through a terminal connection (Telnet), or through FTP.

1. Turn the printer off.
2. Connect the Ethernet cable to the Ethernet port in the rear of the printer and connect the other end of the cable to your network.
3. Turn the printer on.
4. If your printer uses a DHCP server to assign IP addresses, the IP address appears in the lower left corner of the screen.
  - For an icon printer, use Honeywell PrintSet 5 to retrieve the printer IP address.
5. If you are not using a DHCP server to automatically assign IP addresses to devices in your network, you must set a static IP address and other network information manually. Continue with the next step.
6. For a non-DHCP network:
  - For a full touch printer, from the Main Menu select **Settings > Communications > Ethernet > IPv4 or IPv6** and change the settings as needed.
  - For an icon printer, configure the Ethernet settings through Honeywell PrintSet 5.

Setting	Default
(IPv4) IP Assignment Method	DHCP
(IPv4) IP Address	0.0.0.0
Subnet Mask	0.0.0.0
Default Router	0.0.0.0
DHCP Response	Broadcast
(IPv6) IP Assignment Method	Automatic
(IPv6) IP Address	Automatic

## Configure Bluetooth Communications from the Web Page

The printer must be connected to an Ethernet or wireless network and you must know the printer IP address.

1. Open a web browser on your PC.
2. Click **Login**.
3. Type your Username and Password and then click **Login**. The default value for Username is **admin** and the default value for Password is **pass**.
4. Click the **Configure** tab. The Configuration Summary page appears.
5. Click **Communications > Bluetooth**. The Bluetooth settings page appears.
6. Change Bluetooth settings as needed. You can also click **Default Settings** to restore all default Bluetooth settings.
7. Click **Save** when you are finished.

## Configure Bluetooth Communications from the Main Menu

Use this procedure to configure Bluetooth settings from the printer Main Menu. You may need to configure these settings if you want to connect to a mobile computer through Bluetooth.

1. Press the Main Menu button.
2. Select **Settings > Communications > Bluetooth**.
3. Change settings as needed for your Bluetooth device.
4. Tap **Save** when you are finished.

## Printer Drivers

Before you can use the printer with Microsoft® Windows® printing applications, you must install printer driver software on the PC. Drivers enable the printer to communicate with your PC and with software applications such as Honeywell PrintSet 5. (Access the Honeywell Technical Support Downloads portal (<https://hsmftp.honeywell.com>) and go to **Software > Printers > Printer Applications > PrintSet 5.**)

**Note:** *Although Windows may auto-detect the printer when you connect it to a PC through a USB port, you still need to install printer drivers on the PC for the printer to operate correctly.*

## Install Printer Drivers

Use InterDriver to install printer driver software on your PC. Access the Honeywell Technical Support Downloads portal (<https://hsmftp.honeywell.com>) and go to **Software > Printers > Printer Drivers > Intermec Windows driver**.

**Note:** Although Windows may auto-detect the printer when you connect it to a PC through a USB port, you must still install printer drivers on the PC for correct printer operation.

1. Access the Honeywell Technical Support Downloads portal at <https://hsmftp.honeywell.com>.
2. Go to **Software > Printers > Printer Drivers > Intermec Windows driver**.
3. Open the Honeywell Software Download Manager and follow the instructions to download the file.
4. Extract the driver files to a location on your PC.

Double-click the .exe file to install InterDriver and follow the prompts to complete the installation.

## Install Authentication Certificates

If you are using Wireless 802.11 security, you may need to install authentication certificates in the printer for the highest level of security.

1. Configure the printer for the correct date and time.
2. On your PC, open an FTP connection to the IP address of the printer.
3. Transfer your certificate to /home/user/certificates/public.
4. On your PC, open a Telnet session to the printer.
5. Change the directory to: **/home/user/certificates/public**.
6. Type the command: **ls -la**.
7. You should see the certificate that you transferred in step 3.
8. Use the certinstall script to install the certificate using this format:  
**<prompt> certinstall.sh <certificate name>**

```
Example: itadmin@PX940A-12345678 /home/user/certificates/public$  
certinstall.sh entrust.cer
```

9. When you receive confirmation that the certificate was installed, type this command to make sure you see a .pem file and another soft link to the same file: **ls -la**.
10. Use the printer web page (see [Access the Printer Web Page](#)), the Main Menu on a full touch printer, or Honeywell PrintSet 5 to specify the certificate .pem file to use for security.

# USB Host Port

Use the USB host interface port on the printer to connect these peripheral devices:

Device	Description
Keyboard	Use a standard USB keyboard to send Fingerprint printer language commands directly to the printer or to enter information if you are running a Smart Printing application.
Bar code scanner	Use USB bar code scanners for data input with a Smart Printing application. The printer also supports other USB scanners that use a generic keyboard driver.
USB storage device	Use a USB storage device to load applications, configuration files, fonts, and images into the printer memory, or to perform firmware upgrades. You can also save configuration files to a USB storage device for upload to a printer. The USB storage device must have a single partition and be formatted as FAT16 or FAT32.

You can also connect a peripheral device through the USB-to-Serial or USB-to-Parallel adapter cable accessories. Contact your local sales representative for information.

## Connect a USB Device

A USB storage device can be inserted into the USB host port on the front of printer or into the USB host port on the back of the printer.

1. If you are connecting a USB storage device, make sure the device has a single partition and is formatted as FAT16 or FAT32.
2. Connect the device to one of the USB host ports.
3. If you connected a USB storage device to an LCD printer, select **Tools > USB Menu** for more options.



# CONFIGURE THE PRINTER

Use one of these methods to view and change printer settings:

- Printer web page
- Main Menu
- PrintSet 5
- Programming commands

## Printer Configuration Menus

The structure of the printer configuration menus is consistent among the different interfaces. The same organization appears whether you are accessing the menus through the web page or the printer Main Menu. There are four main printer configuration menus for each interface:

- Printing
- System Settings
- Verifier (PX900V only)
- Alert

Use the following illustrations to understand where information is located in the printer configuration menus. Not all configuration items appear in each type of interface.

# Printing Menu

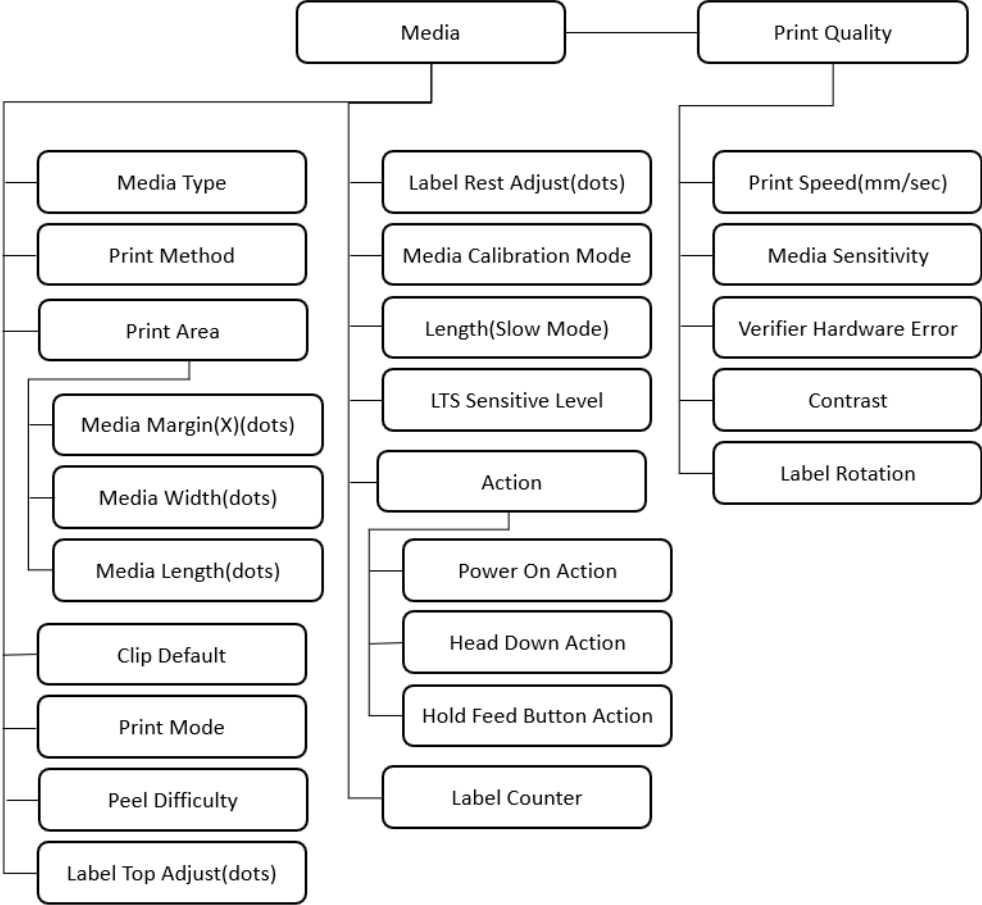



# System Settings Menu

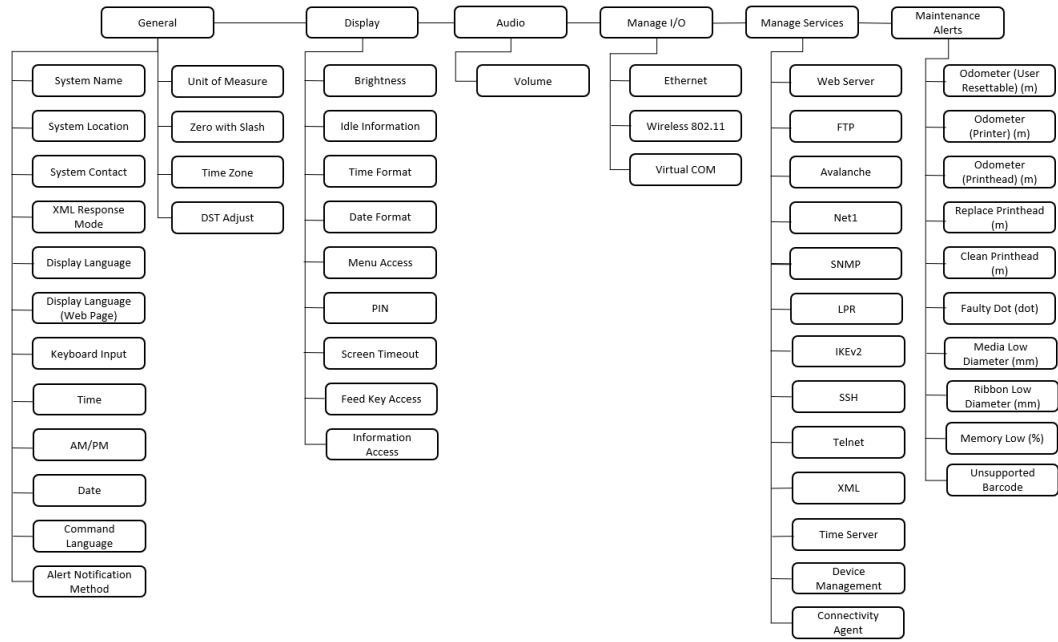

# Verifier Menu

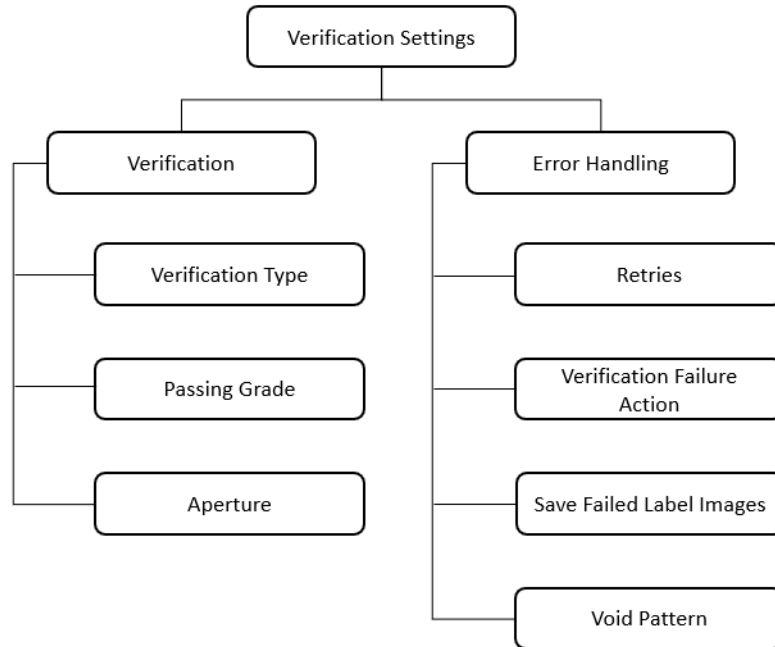

# Alert Menu

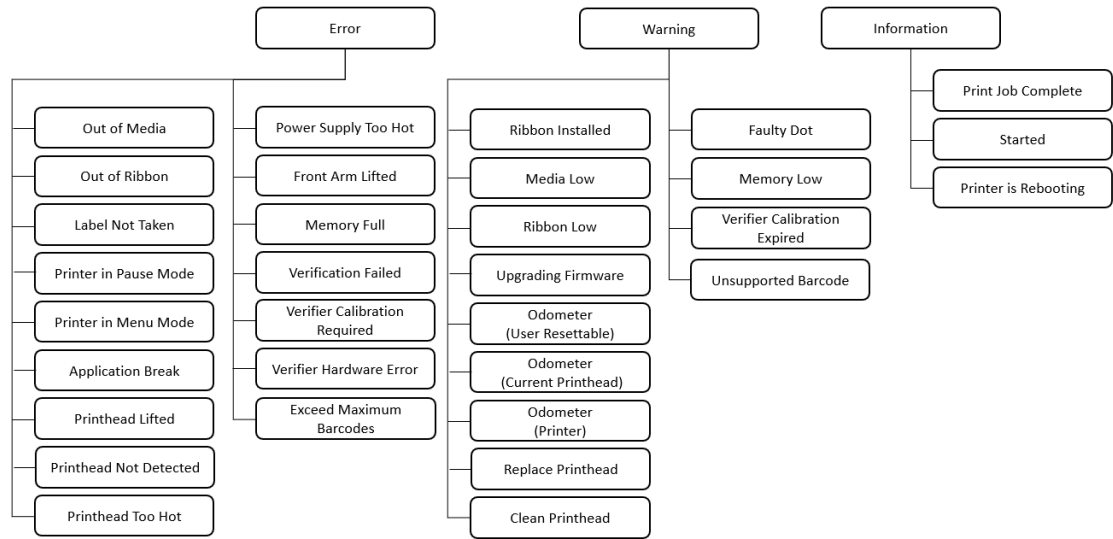

## Printer Configuration

Configure the Printer from the Main Menu

If you have a full touch printer, you can view or change the configuration settings by pressing the **Settings** button from the Main Menu.

1. From the Ready screen, press the Main Menu button.
2. From the Main Menu, press the **Settings** button. The Settings menu appears.
3. Select the settings you want to configure and make your changes.
4. Save your changes when prompted.

## Restrict Access to the Main Menu

By default, all menus are available from the Main Menu the first time you turn on the printer. If necessary, you can require a PIN to restrict access to menus or you can disable access to all menus.

Menu Access Setting	Description
Enable (default)	All users can access the menus from the Main Menu and from the USB flash drive menu.
Enable with PIN	Users need to enter a PIN to access the Main Menu or USB flash drive menu.
Disable	Users cannot access the menus from the Main Menu or from the USB flash drive menu.

1. Go to the Display menu for the printer:
  - From the web page (see [Access the Printer Web Page](#)), select **Configure > System Settings > Display**.

- From the Main Menu on a full touch screen, select **Settings > System Settings > Display**.
2. Select a Menu Access setting and save your changes.
  3. If you select **Enable with PIN**, you also need to type in a PIN and save your changes.

## Access the Printer Web Page

4. Open a browser window on your PC.
5. In the location or address bar, type the printer IP address and press **Enter**. The printer web page appears.
6. Click **Login**. The login page appears.

## Printer Webpage User Name and Password

You will be prompted for a user name and password. The default username is **itadmin** and the default password is **pass**.

## Configure the Printer from the Web Page

If you are using Ethernet or WiFi communications, you can change configuration settings from the web page of the printer. Connect the printer to your network and obtain an IP address.

1. Open a web browser on your PC.
2. In the address bar, type the IP address of your printer and press **Enter**. The printer web page appears.
3. Click **Login**. The Login page appears.
4. Type your Username and Password and then click **Login**. The default value for Username is **itadmin** and the default value for Password is **pass**.
5. Click **Configure**. The Configuration Summary page appears.
6. To see a complete list of printer settings, click **Configuration Summary**.
7. To configure printer settings, click an item in the navigation pane:
  - For serial, Ethernet, Wireless 802.11, or Bluetooth settings, click **Communications**.
  - For media or print quality settings, click **Printing**.
  - For display, audio, service, and general settings, or maintenance alert message triggers click **System Settings**.
  - To set conditions that trigger error, warning, and information alert messages, click **Alerts**.

- For network-related settings (such as DNS, WINS, Net1), for web and email server information, or if you are using a network management application, click **Network Services**.
8. Make any changes to the settings you want to configure.
  9. To save your changes, click **Save**.
  10. To reset all parameters on the page to the default settings, click **Default Settings**.

## Configure the Printer with Honeywell PrintSet 5

You can use PrintSet 5 to change configuration settings on your printer. Download the PrintSet 5 console from the App Store onto your mobile device.

You can download Honeywell applications to extend the capabilities of the printer. You may need to purchase a license to run some applications. To learn more about the PrintSet 5, licenses, and other Honeywell software solutions, go to [www.honeywellaidc.com](http://www.honeywellaidc.com) > **Browse Products** > **Software**.

Support for Honeywell Safety and Productivity Solutions products is available online through the Technical Support Portal.

## Configure the Printer with Programming Commands

You can change configuration settings by sending programming commands directly from your PC to the printer through a terminal program (such as HyperTerminal), a serial connection, or a network connection.

If your printer uses the Fingerprint programming language, use the SETUP GET command followed by the node, subnode, and parameter setting. For example, this changes your media setting to labels with gaps:

```
SETUP GET "MEDIA,MEDIA TYPE,LABEL (W GAPS)"
```

You must log in as an itadmin to perform a SET operation, but you do not need to log in to perform a GET operation.

If your printer uses the IPL programming language, this example changes your media setting to labels with gaps:

```
<STX><SI>T1<ETX>
```

For more information on how to change configuration settings with a programming language, see either the Fingerprint Command Reference or the IPL Command Reference.

## Uploading from the Web Page

You can use the printer web page to install fonts, images, applications, formats, and web forms to the printer.

1. Open a web browser on your PC.
2. In the address bar, type the IP address of your printer and press **Enter**. The printer web page appears.
3. Click **Login**. The Login page appears.
4. Type your Username and Password and then click **Login**. The default value for Username is **itadmin** and the default value for Password is **pass**.
5. Click the **Manage** tab. The Overview page appears.
6. Click on the desired item in the Overview list. The upload page appears for the option you selected. For example, this is the Fonts page:

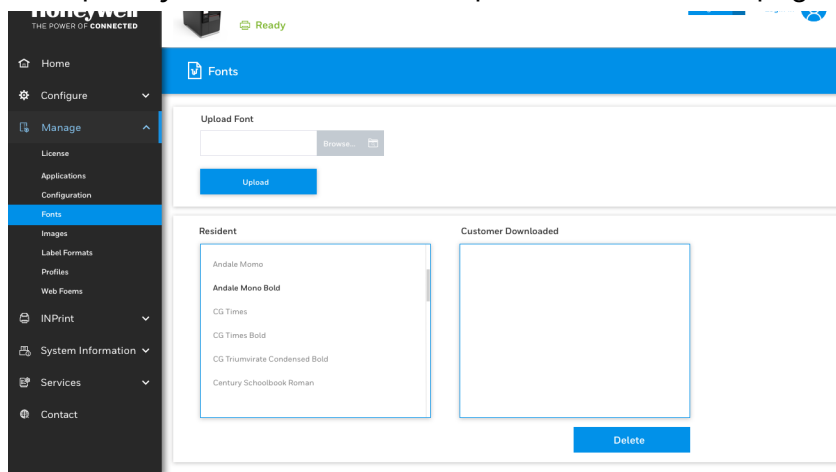

7. To upload a file to the printer, click **Browse** to locate your file. Double-click the file to select it, then click **Upload**. The file uploads to the printer.
8. Click **Save** when you are finished.

## Uploading from a USB Storage Device

You can use a USB storage device to install fonts, images, applications, formats, and web forms to the printer. Use this table to understand where your files need to be located on the USB storage device for the printer to install them.

File Type	Directory to Place the File	Installed in this Printer Directory
Application	/apps	/home/user/apps
Configuration	/config	
Configuration profile	/profiles	/home/user/profiles
Display images	/display	/home/user/display

File Type	Directory to Place the File	Installed in this Printer Directory
Fingerprint script	/scripts	/home/user/scripts
Firmware	/firmware	
Font	/fonts	/home/user/fonts
Form/layout	/forms	/home/user/forms
Printed images	/images	/home/user/images
Installation package (UFF file)	Root of USB storage device	
Start file	Root of USB storage device	
Web Form	/webforms	/home/user/webforms

1. Copy your files to a USB storage device using the directories in the table.
2. Insert the USB storage device into one of the USB host ports on the printer.
3. If you have an icon printer, the files are automatically uploaded to the printer. If you have a full touch printer, the USB Device menu automatically appears:
  - a. Select **Install Resources**.
  - b. Select the file you want to install and wait until the item turns gray and a checkmark appears next to it. The file is now successfully installed in the printer.
  - c. Continue to another file if you have more files to install.

## Change Background Image for the Ready Screen

You may customize the Ready screen that appears on the printer. The background image you create must be:

- 320 x 240 pixels.
- named **background\_idle.png**.

1. Create a /display directory on your USB storage device.
2. Copy your **background\_idle.png** file to the **/display** directory on the USB storage device.
3. Insert the USB storage device into one of the USB host ports on the printer.
4. If you have an icon printer the file is automatically uploaded to the /home/user/display directory on the printer.
5. If you have a full touch printer, use the USB Device menu to upload the file to the printer.
6. Restart the printer.

The new image file you uploaded appears in place of the original Ready screen.

# Printer Profiles

You can save updated printer default settings as a printer profile. The printer supports multiple profiles that can be saved and loaded at any time. For example, you can create one profile to use when you are printing on continuous label stock, and a different profile to use when you are printing on label stock with gaps.

The following printer settings are not saved in a profile:

- IP address for either IPv4 or IPv6 networks
- Media calibration settings for the label stop sensor
- Remote port or remote host values for a remote computer accessing the printer through raw TCP

## Save a Printer Profile from the Web Page

From the printer web page, you can save the current settings as a profile that you can load from the printer memory at any time.

1. In the printer web page (see [Access the Printer Web Page](#)), click the **Configure** tab.
2. Click **System Settings > General**.
3. Click **Save As Profile**. The Save As Profile screen appears.
4. Enter a name in the Profile field, and then click **Save**.

## Load a Printer Profile from the Web Page

You can load a saved profile from the printer web page.



1. In the printer web page (see [Access the Printer Web Page](#)), click the **Manage** tab.
2. Click **Profiles**.
3. The Resident list includes profiles that are saved in the printer memory.
4. To load a profile from the printer memory, select the profile in the Resident list and then click **Activate**. The profile is loaded.
5. To load a profile from another location, click **Browse** and browse to the location of the file. Double-click the file to select it, then click **Upload**. The profile is uploaded to the printer.

## Save a Printer Profile from the Main Menu

Use this procedure to save the current settings as a printer profile.



1. From the Ready screen, press the Main Menu button. The Main Menu appears.
2. Select **Tools > Profiles**. The Profiles menu appears.
3. Select **Create**. The Create Profile menu appears.

**Note:** *selecting Create acts as the Save function*

4. Select the **Filename** text box and type a name for the profile. The profiles can have up to sixteen characters.
5. Press  on the SIP to save your profile name and go back to the Save Profile menu.
6. Press  and wait until **Complete** appears on the screen.
7. Press  to return to the Main Menu.

## Load a Printer Profile from the Main Menu

Use this procedure to load a saved printer profile on the full touch printer.

1. From the Ready screen, press the Main Menu button. The Main Menu appears.
2. Select **Tools > Profiles**. The Profiles menu appears.
3. Select **Load**. The Load Profile menu appears.
4. Select the profile you want to load on the printer and press .
5. When **Complete** appears on the screen, press  to return to the Main Menu.

## Load a Printer Profile Using Programming Commands

You can load a saved LCD printer profile to another printer by sending programming commands directly from your PC to the printer through a terminal program (such as HyperTerminal), a serial connection, or a network connection. All commands are case-sensitive.

**Note:** *To load printer profiles that modify communication settings that require itadmin rights, you must log in as an itadmin: RUN "su -p pass".*



Connection	Programming Commands
Printer running Fingerprint	RUN "/system/usr/bin/cfg -o xmlimportset -k /home/user/profiles/myprofile"
Printer running IPL	<STX><ESC>.x./system/usr/bin/cfg -o xmlimportset -k /home/user/profiles/myprofile<ETX>
Telnet connection over Port 23	/system/usr/bin/cfg -o xmlimportset -k /home/user/profiles/myprofile

## Install a Configuration File from a USB Storage Device

After you save an .xml configuration file to a USB storage device, you can install it on the printer at any time.

**Note:** *If there is more than one configuration file on the USB storage device, the printer imports the first file found alphabetically by file name.*

1. Insert the USB storage device in the printer USB host port.
2. From the Ready screen, press the Main Menu button. The Main Menu appears.
3. Select **Tools > USB Menu**.
4. Select **Configuration**.
5. Select **Install Configuration**. The printer imports the configuration file.
  - For most printer languages, the configuration file is imported directly into the working configuration and is not copied to the /config directory.
  - An IPL configuration file is copied to /home/user/config/ipl.
6. Press **OK** when the confirmation message appears.

## Export a Configuration File to a USB Storage Device

You can save an .xml configuration file to a USB storage device and install it on other printers.

1. Make sure the USB storage device has a single partition and is formatted as FAT16 or FAT32.
2. Insert the storage device into the printer USB host port.
3. From the Ready screen, press the Main Menu button. The Main Menu appears.
4. Select **Tools > USB Menu**.
5. Select **Configuration**.
6. Select **Export Configuration**. A list of the available files appears.
7. Select the file to export.
8. Press **OK** when the confirmation message appears.

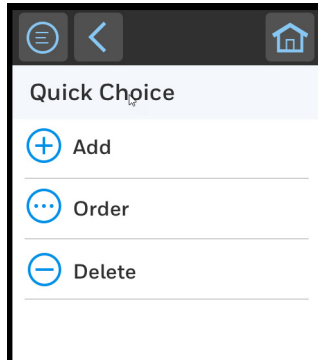

# Menu Shortcuts

If you have a full touch printer, you can create shortcuts to access frequently used menus or items, such as profiles, applications, test labels, and wizards. These shortcuts are added to a Quick Choices menu, which replaces the Main Menu.



The Main Menu appears as the first item in the Quick Choice menu. Items in the Quick Choice menu appear in the order in which they are added. The Main Menu always appears as the first item.

Menu shortcuts can be very useful in these situations:

- You need to frequently change media. Create a profile for each media type and create shortcuts for each profile. To quickly change the printer media settings, press the Main Menu icon  from the Ready screen to display the Quick Choice menu, then select the appropriate media profile.
- You frequently run Smart Printing applications. Create a shortcut for each Smart Printing application. To access these applications, press the Main Menu icon  from the Ready screen to display the Quick Choice menu, and select the appropriate application.

## Create Menu Shortcuts

1. From the Main Menu, select **Tools > Quick Choices > Add**.
2. To load a profile:
  - a. Select **Load Profile**
  - b. Select **Load Profile** again and a check mark appears in the box.
  - c. Select the arrow at the bottom of the screen.
  - d. Select the check mark icon at the bottom of the screen.
3. To select applications:
  - a. Select **Programs**.
  - b. To add a Program, select each program and a check mark appears in each box.
  - c. Select the check mark icon at the bottom of the screen.

4. To select test labels:
  - a. Select **Tools**
  - b. Select **Test Labels** .
  - c. To add individual test labels, select each test label option and a check mark appears in each box.
  - d. Select the check mark icon at the bottom of the screen.
5. To select wizards:
  - a. Select **Wizards**.
  - b. To add individual wizards, select each wizard and a check mark appears in each box.
  - c. Select the check mark icon at the bottom of the screen.
6. The next time you press the Main Menu icon  from the Ready screen, the Quick Choice menu (containing the Main Menu and your menu shortcuts) appears.

## Customize the Printer Web Page

The printer web page visual presentation is specified using a CSS (Cascading Style Sheet). You can customize the look of the web page by modifying the CSS. The printer web page loads the default style.css prior to loading the user customized style.css. The customized style.css does not need to contain the complete set of CSS directives, it may only specify the subset of CSS styles that the user wishes to customize.

1. Retrieve the default CSS file from the printer: `http://<printerip>/format/style.css`.
2. Modify the style sheet and save your changes.
3. Upload the style sheet to the printer via `/home/user/webpage/style.css`.



## ABOUT THE VERIFIER

The verifier provides commercial, error-free barcode printing and identifies and verifies the barcodes in printed outputs using supported command languages.

When labels are printed, the verifier ensures barcode readability.

## Setting up the Verifier

The verifier can be configured through the webpage:

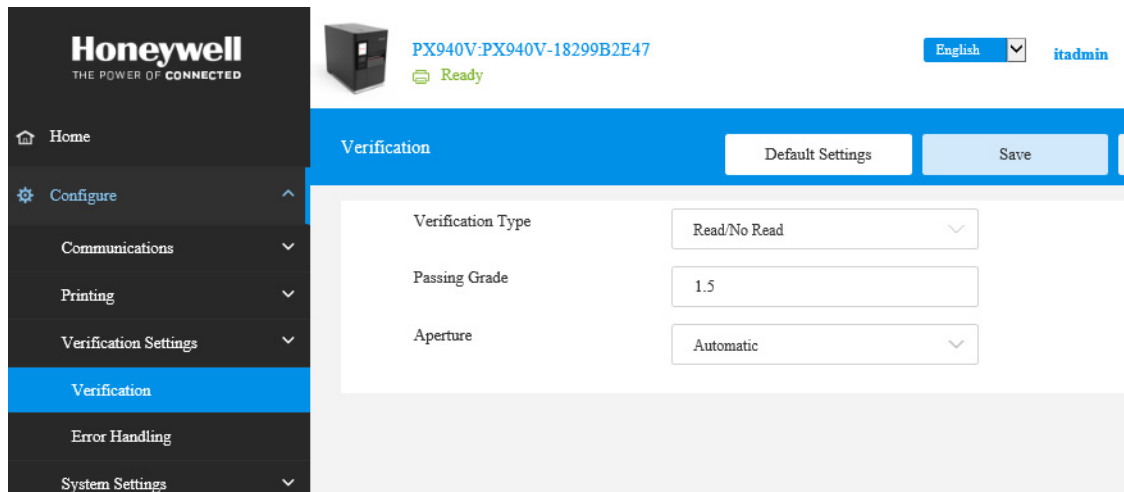

or the front touch panel:

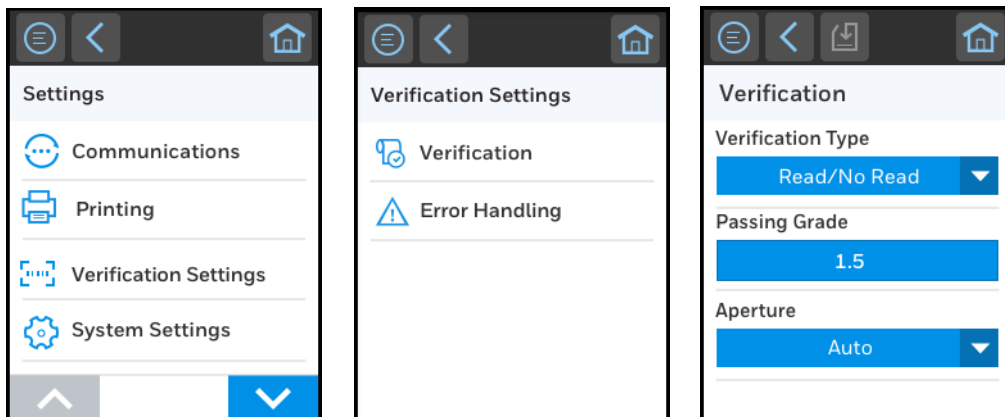

## Webpage

The supported features are listed as the following:

- Verification configurations
- Verification statistics
- Restore default verification database and failed label image files
- Verification reports for download

## Front Panel

The supported features are listed as the following:

- Verifier Calibration Wizard
- Verification Results Display Wizard - Allow the user to browse through all the barcodes detailed result in the last label printed.

USB menu to export all verification reports and saved label image file.

## Verifier License

The verifier feature is activated when the appropriate license is installed on the printer.

To install verifier license from the touch screen, go to **Tools > USB Menu > Install Verifier License**

For more help on installing the verifier license, visit [www.honeywellaidc.com](http://www.honeywellaidc.com)

## Calibration

Calibrating the verifier maintains the accuracy of the verifier when scanning an image. Calibration is usually performed prior to the shipment of the printer.

## Verifier Calibration Card

The calibration card is used to calibrate the verifier. It is very important to follow the instructions on the calibration card packaging for proper care of the calibration card. If you lose your calibration card, visit [www.honeywellaidc.com](http://www.honeywellaidc.com).

If your verifier is not calibrated, follow these steps:

1. Open the verifier arm and print head arm.
2. Remove any media and ribbon from the printer media path.
3. Clean the TPH, platen roller and verifier glass with a soft, lint-free cloth and isopropyl alcohol.
4. Place the calibration card on the media path, according of the instructions written on the card.

- The three chevrons on the card indicating the orientation. The "FRONT" text on the card placed outside of the verifier
- Align the black line with the printer tear bar. Use the diamond cut out on the calibration card black line to align to the tear bar.

**Note:** You should see the tear bar through the diamond cut on the calibration card black line.

- Align the card evenly toward the printer spine and resting against the media guide.
5. Close the verifier arm and then the printhead arm.
  6. From the front touch panel, go to: **Wizards > Calibration > Verifier** and follow the instructions.
  7. Press **NEXT** on the touch screen.
    - The card will move back and forth as the calibration process is running.
  8. Once completed, the front panel will show if the calibration pass or fail.

**Note:** If Calibration fails, see [Verifier Error Alerts and Solutions](#), beginning on page 65.

## Verifier Settings

This section gives a brief description of the verifier settings. For more details about Verification Settings, see [Appendix A](#).

## Verification Type

Select the verification type to check the barcode.

- None - No barcode validation
- Read/No Read - Validate if barcode is readable
- ISO15415/15416 - Full ANSI grading of barcode

## Passing Grade

Sets the minimum passing grade for barcode grading. Grade 0.0 (F) is the lowest grade. Grade 1.5 (C) is the default and recommended by ISO standard. Only applied when verification type is set to ISO15415/15416.

## Aperture

Indicates the aperture size (in mils) used for verification. Aperture size will be chosen automatically based on ISO standard. Change only if required by an overriding application.

## Retries

Sets maximum number of times printer reprints label after verification failure. This setting is only applicable when the Verification Failure Action is set to Void and Reprint.

## Verification Failure Action

Indicates action to take when label fails verification.

- Void and Reprint - Retract and void the failed label, then reprint the failed label. Stop reprint if the maximum retries have been reached.
- Void and Print Next - Retract and void the failed label, then continue to print the next label.
- Pause for User Action - Stop the printing once the label verification fails and prompt the user for action to take.
- Ignore and Continue - No voiding when verification fails. Result is saved and next label is printed.

**Note:** *Note: During multiple label printing, printer will void the failed label (plus all printed and yet to be verified labels) in order to keep the good labels in sequence.*

## Save Failed Label Images

When enabled, the printer saves all failed label images in non-volatile memory. Maximum 100 images can be saved (if memory available). At maximum capacity oldest image file will be replaced by newest.

## Void Pattern

Select the void pattern type to mark the failed label.

## Print Modes and Speed

The printer works for the following mode:

- Printer command language: Autosense, FP/DP, ZPL, IPL, DPL
- Recommended maximum print speed: 4ips for 203 and 300 dpi; 2 ips for 600 dpi

**Note:** *Voiding not supported in peel off mode*



## Barcode Symbologies Supported

The verifier supports the following barcode symbologies:

- Code 39
- HIBC 39
- Code 128
- ISBT-128
- HIBC 128
- EAN-8
- EAN-13
- EAN-128
- UPC-A
- UPC-E
- UPC Shipping Container Code
- Interleaved 2 of 5
- ITF-14
- Data Matrix
- ISBT Data Matrix

## Barcode Orientations

- Picket or ladder orientation

## Barcode Size Supported

- Minimum 1D barcode size: 10 mils
- Minimum 2D barcode size: 15 mils

## Verification Length

Support maximum verification length up to 12 inches

## Maximum Number of Barcodes per Label

A total of 32 barcodes can be scanned and verified per label. If the number of barcodes on one label exceeds 32, the verifier system will show an error message.

# Printing Behavior after Error Recovery

Possible printer error during printing & verification:

- Printhead lifted
- Front arm lifted
- Next label not found
- Out of media
- Out of ribbon
- Ribbon installed

## Printing Behavior after Recovered from error above:

1. No void printing. User will need to manually mark/discard the labels between the verifier module and printhead.
2. Reprint all unverified labels and verification failed labels.

The following diagrams show which labels will be reprinted in different scenarios.

### Scenario 1

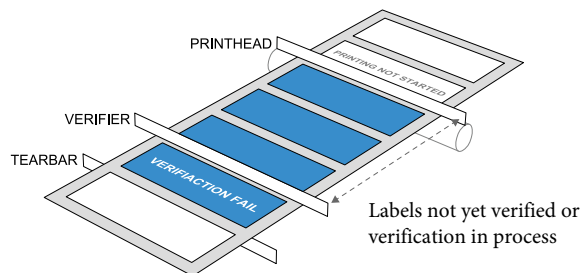

- All blue labels will be reprinted and verified after error recovery.
- All blue labels will be marked as **FAIL** in verification result database.

### Scenario 2

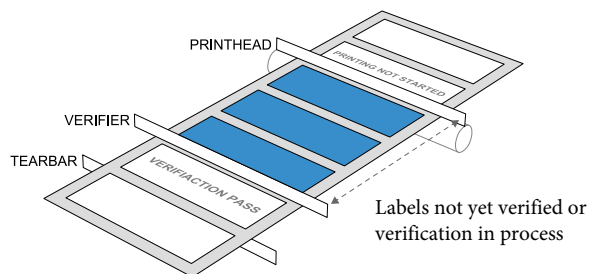

- All blue labels will be reprinted and verified after error recovery.
- All blue labels will be marked as **FAIL** in verification result database.

### Scenario 3

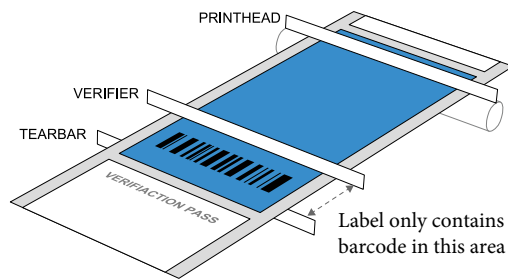

- Label verification in progress.
- This label will be marked **PASS** in verification result database.

### Scenario 4

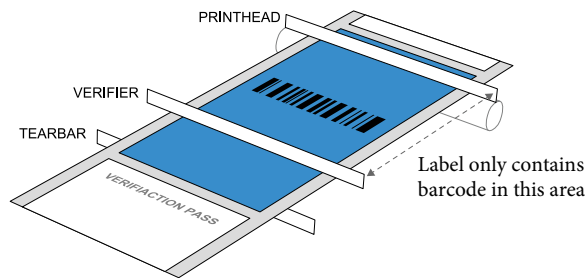

- Label verification in progress.
- This label will be marked FAIL in verification result database.

## Printing Errors

Possible reasons for error during printing & verification:

- Printhead lifted
- Front arm lifted
- Next label not found
- Out of media
- Out of ribbon
- Ribbon installed

## Unsupported Barcode Behavior

The printer will display an “Unsupported Barcode” warning message in all user interfaces (UI, webpage, SNMP, Printset, etc.) if there is an unsupported barcode type or unsupported barcode size in the label.

In the verification report, if all the supported barcodes in the label are PASS, then “Label Status” will display PASS and the printer will rely on the “Label Status” for verification failure handling.

If there an unsupported barcode exists in the label, there will be a status field to indicate the barcode is unsupported due to unsupported type or unsupported size.

### Example:

Scenario 1: All barcodes printed on the label are unsupported or unsupported size

- Label Status = Pass
- Individual barcode status = Unsupported Barcode / Unsupported Size
- UI display “Unsupported Barcode” warning message

Scenario 2: At least one barcode printed on the label is supported

- Label Status = Pass/Fail (based on supported barcode)
- Individual barcode status = Pass/Fail/Unsupported Barcode/Unsupported Size
- UI display “Verification Fail” if label status is Fail, otherwise it will display “Unsupported Barcode”

## Verification Failed Error Handling

When the print job's barcode has failed in the verification process, there are several ways to identify and fix the issue:

- Voiding the label and reprinting (default)
- Voiding the label without reprinting
- Pause print job and wait for user action
- No voiding and proceed with subsequent print jobs

**Note:** All actions above will be automatically executed, except **pause print job and wait for user action**. During void and reprint process, the print job pause action is not supported.

**Note:** In the Webpage menu, **Services > Verifier Image**, you can access the last label image scan (if available)

## Failed Label Image File

Summary	Description
Image Format	JPG
Maximum Files	100 files or flash memory is 75% full before the printer start to replace the oldest file in a round robin.
Path	/home/user/verifier/images
File name	<Printer Model Name>_<Printer Serial Number>_<LabelID>_YYYYMMDD_HHMMSS.jpg Example: PX940V_0000001234567_1_20181026_142800.jpg

The failed label image will not be generated if one of the following scenarios is true

- All supported barcodes in the label are meeting the passing grade or readability criteria.
- "Saved Failed Label Images" setting is disabled.

The example below shows the number of failed label image saved when the "Saved Failed Labels" setting is enabled and "Retries" setting set to 3.

- Initial print - FAIL (save the failed label image)
- First reprint - FAIL (save the failed label image)
- Second reprint - PASS

Total failed label image saved is 2.

The failed label image file can be downloaded through the following method:

- USB Thumbdrive
- FTP
- Webpage

## USB Thumbdrive

1. Export all existing individual verification reports and failed label image files
  - Insert the USB thumb drive to the printer
  - Go to TOOLS menu from the LCD to export all verification results (individual verification report and failed label image if any)
  - Select "Remove USB" in USB menu in order to safely remove the USB thumbdrive.

**Note:** If images are saved on a thumbdrive, the limit is the thumbdrive capacity.

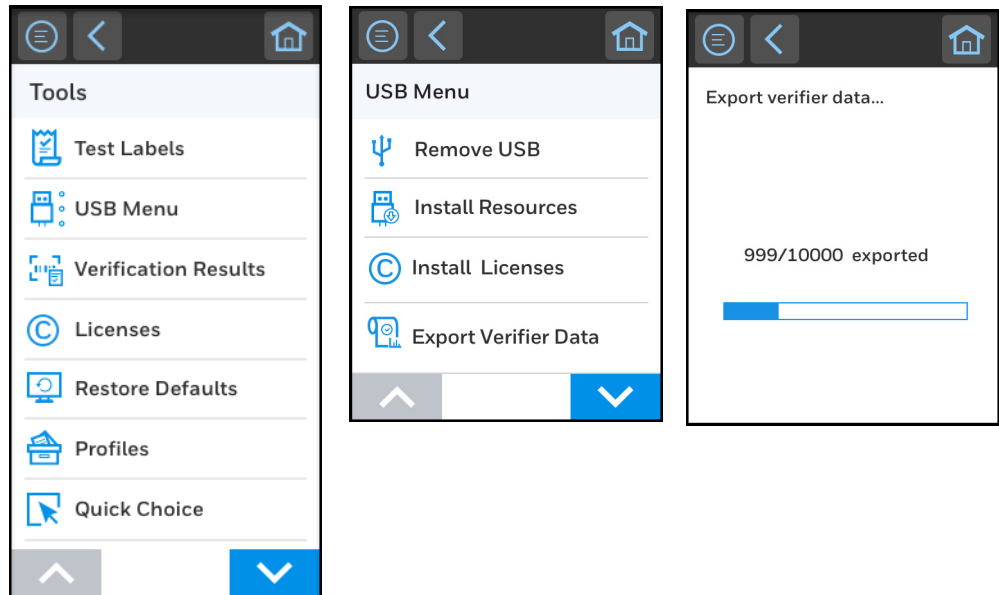

## 2. Saving verification results in run-time

- Create a directory in the root of USB thumbdrive named “verifier”
- Insert the USB thumbdrive to the printer
- The printer will start saving from the next verification XML report and failed label image if any to the USB thumbdrive.
- Select "Remove USB" in USB menu in order to safely remove the USB thumbdrive.

## Reporting and Statistics

In the **Webpage > System Information > Statistics > Verification Results** you can see the list of the individual reports (if available).

You can also see the number of labels verified, failure rates, and print statistics.

# Report Formats

Summary	Description
File Format	xml
File Name	Individual report:  <Printer Model Name>_<Printer Serial Number>_<Label ID>_<YYYYMMDD>_<HHMMSS>.xml Example: PX940V_0000001234567_1_20181026_142800.xml  Summary report:  <Printer Model Name>_<Printer Serial Number>_<Start of Label ID>_<End of Label ID>.xml Example: PX940V_0000001234567_1_50.xml
Content	The various measured parameters for all verified barcodes found in the label

## Individual Report

For individual report, it saves the detailed information of the barcodes in the label. The content includes barcode type, size, encoded data, ANSI grade and the detailed parameter of ANSI grade. Each individual label report consists of 3 parts.

- Report header
- Barcode information
- Barcode grading parameter (not applicable for Read/No Read verification type)
- 1D Barcode 10 line profile grading parameter (not applicable for Read/No Read verification type)

## Report Header

Content	Read/No Read	ISO 15415/15416	Description
Label ID	Yes	Yes	Unique counter for each printed label. Reset to 1 when user reset the verification user storage/database Example: <Label ID="1"> - First label verified after reset.
PrintJob ID	Yes	Yes	Unique counter for each print job. Reset to 1 when user reset the verification user storage/database Example: <PrintJobID>1<PrintJobID> - First print job after reset
Verification Type	Yes	Yes	Barcode verification type Example: <VerificationType>Read/No Read</VerificationType>
Passing Grade Threshold	No	Yes	Passing grade threshold - not applicatble for the Read/NoRead and GS1 application. GS1 will have an individual passing grade for each barcode type defined in the profile. Example: <PassingGrade>1.5 (C)</PassingGrade>
Hardware Aperture	Yes	Yes	Integrated verifier sperture size measured. Example: <hardwareAperture>4.4 mils</HardwareAperture>
Date	Yes	Yes	Date when the label is printed Format: YYYYMMDD Example: ,Date>20180320</Date>
Time	Yes	Yes	time when the label is printed Format: HHMMSS Example: <Time>131120</Time>
Last Calibration Date	Yes	Yes	Last verifier calibration date "Expired" will be indicated if the last calibration date is past the duration determined by the design. Format: YYYYMMDD Example: <CalibrationDate>20180320</CalibrationDate> or <CalibrationDate>Expired</CalibrationDate>
Label Grade	No	Yes	Indicate the lowest grade of the barcode in the label Example: <LabelGrade>3.3 (B)</LabelGrade>
Label Status	Yes	Yes	Verification status for the label, Pass or Fail Example: <LabelStatus>Pass</LabelStatus>
Image	Yes	Yes	Failed label image file name Example: <Image>PX940V 0000001234567 1 20180322 093000.jpg</Image>
Barcodes	Yes	Yes	A total number of barcodes in this label



# Barcode Information

Content	Read/ NoRead	ISO 15415/ 15416	Description
Barcode ID	Yes	Yes	Unique number for individual barcode in each label. Number start from 1. Example: <Barcode ID="1">
Symbology	Yes	Yes	Barcode type Example: <Symbology>CODE39</Symbology>
Size	Yes	Yes	Barcode size Example: <Size>9.8 mils</Size>
Data	Yes	Yes	Decoded data. For Read / No Read, this field will leave empty if failed in either one of the passing criteria. Example: <Data>1234567890</Data>
Grade	No	Yes	Grading results for this barcode Example: <Grade>3.3 (B)/5/660</Grade>
Status	Yes	Yes	Verification status for this barcode, Pass or Fail Example: <Status>Pass</Status>
Scan Line Data Check	Yes	Yes	Scan line data consistency check status for 1D barcode. Status: a) Pass - All 10 scan line data is same. b) Fail - At least 1 of the scan line data mismatched with others. c) NA - 2D barcode Example: <ScanLineDataCheck>Pass</ScanLineDataCheck>
X position	Yes	Yes	Barcode X coordinate start position in pixel. Refer to the diagram below for barcode's coordinate details. Example: <XPos>100</XPos>
Y position	Yes	Yes	Barcode Y coordinate start position in pixel. Refer to the diagram below for barcode's coordinate details. Example: <YPos>100</YPos>
Width	Yes	Yes	Barcode width in pixels Example: <Width>720 pixels</Width>
Height	Yes	Yes	Barcode height in pixels Example: <Height>480 pixels</Height>

## All Supported 1D Barcodes Overall Parameters

Content	Description
R Max	The highest reflectance in any element or quiet zone in a scan reflectance profile, or the highest reflectance of any sample area in a two-dimensional matrix symbol. Example: <RMax>79.2%</RMax>
R Min	The lowest reflectance in any element in a scan reflectance profile, or the lowest reflectance of any sample area in a two-dimensional matrix symbol. Example: <RMin Grade="4.0">0.5%</RMin>
Min Edge Contrast	The minimum difference between bar reflectance and space reflectance of two adjacent elements. Example: <ECMin Grade="4.0">67.2%</ECMin>
Symbol Contrast	The difference between the highest and lowest reflectance values in a scan reflectance profile. Example: <SymbolContrast Grade="4.0">84.0%</SymbolContrast>
Modulation	The ratio of minimum contrast to symbol contrast. Example: <Modulation Grade="4.0">80.0%</Modulation>
Defects	Irregularities found within elements and quiet zones; measured in terms of element reflectance non-uniformity. Example: <Defects Grade="4.0">8.5%</Defects>
Decodability	A measure of the accuracy of its production in relation to the appropriate reference decode algorithm. Example: <Decodability Grade="4.0">76.5%</Decodability>
Decode	Decodable symbols shall comply with the symbology specification. Value in grade. Example: <Decode Grade="4.0"/>
Quiet Zone	The areas to the left and right of the barcode that is free from text or graphics to successfully read the barcode. Example: <QuietZone Grade="4.0"/>
Global Threshold	The reflectance level midway between the maximum and minimum reflectance values in a scan reflectance profile, used for the initial identification of elements. Example: <GlobalThreshold>42.5%</GlobalThreshold>
Print Contrast Signal	The contrast between bars and spaces or background. Example: <PCS>99.4%</PCS>
Average Bar Gain	Average bar gain or loss in percentage Example: <BarGain>-1.1%</BarGain>

## 2D Barcode, Datamatrix Overall Parameters

Content	Description
R Max	The highest reflectance in any element or quiet zone in a scan reflectance profile, or the highest reflectance of any sample area in a two-dimensional matrix symbol. Example: <RMax>86.6%</RMax>
R Min	The lowest reflectance in any element in a scan reflectance profile, or the lowest reflectance of any sample are in a two-dimensional matrix symbol. Example: <RMin>16.8%</RMin>
Symbol Contrast	The difference between the highest and lowest reflectance values in a scan reflectance profile. Example: <SymbolContrast Grade="4.0">69.8%</SymbolContrast>
Modulation	A measure of the uniformity of reflectance of the dark and light modules, respectively. Example: <Modulation Grade="4.0"/>
Decode	Decodable symbols shall comply with the symbology specification. Value in grade Example: <Decode Grade="4.0"/>
Axial Nonuniformity	Measures the grades and spacing of the mapping centers (sampling points) or intersections of the grid and tests for uneven scaling of the symbol. Example: <AxialNonuniformity Grade="4.0">1.9%</AxialNonuniformity>
Grid Nonuniformity	Measures and grades the largest vector deviation of the grid intersections. Example: <GridNonuniformity Grade="4.0">5.4%</GridNonuniformity>
Unused Error Correction	Tests the extent to which regional or spot damage in the symbol has eroded the reading safety margin that error correction provides. Example: <UnusedEC Grade="4.0">100.0%</UnusedEC>
Fixed Pattern Damage	Tests the damage to the finder pattern, quiet zone timing, navigation, and other fixed patterns. Example: <FixedPatternDamage Grade="4.0"/>
L1 (left of L finder)	L1 in grade Example: <L1 Grade="4.0"/>
L2 (bottom of L finder)	L2 in grade Example: <L1 Grade="4.0"/>
QZL1 (left quiet zone)	QZL1 in grade Example: <QZL1 Grade="4.0"/>
QZL2 (bottom quiet zone)	QZL2 in grade Example: <QZL2 Grade="4.0"/>
OCTASA (overall clock track and solid area)	OCTASA in grade Example: <OCTASA Grade="4.0"/>

Content	Description
AG (average grade)	AG in grade Example: <AG Grade="4.0"/>
Contrast Uniformity	The minimum MOD value found in any module contained in the data region of the symbol and does not affect the overall grade. Example: <ContrastUniformity>52.8%</ContrastUniformity>
Print Growth X	Print growth X in percentage Example: <PrintGrowthX>9.3%</PrintGrowthX>
Print Growth Y	Print growth Y in percentage Example: <PrintGrowthY>9.3%</PrintGrowthY>
MatrixSize	Matrix size Example: <MatrixSize>16x16</MatrixSize>

# 1D barcode 10 line Profile Grading Parameters

Content	Description
Line ID	Scan line number for individual barcode. Number start from 1. Example: <Line ID="1">
Grade	Grading results for this barcode line Example: <Grade>3.3</Grade>
R Max	The highest reflectance in any element or quiet zone in a scan reflectance profile, or the highest reflectance of any sample area in a two-dimensional matrix symbol. Example: <RMax>79%</rMax>
R Min	The lowest reflectance in any element in a scan reflectance profile, or the lowest reflectance of any sample are in a two-dimensional matrix symbol. Example: <RMin Grade="4.0">0.2%</RMin>
Min Edge Contrast	The minimum difference between bar reflectance and space reflectance of two adjacent elements. Example: <ECMin Grade="4.0">68.4%</ECMin>
Symbol Contrast	The difference between the highest and lowest reflectance values in a scan reflectance profile. Example: <SymbolContrast Grade="4.0">83.3%</SymbolContrast>
Modulation	The ratio of minimum edge contrast to symbol contrast. Example: <Modulation Grade="4.0">82.2%</Modulation>
Defects	Irregularities found within elements and quiet zones; measured in terms of element reflectance. Example: <Defects Grade="4.0">6.2%</Defects>
Decodability	A measure of the accuracy of its production in relation to the appropriate reference decode algorithm. Example: <Decodability Grade="4.0">75.5%</Decodability>
Decode	Decodable symbols shall comply with the symbology specification. Value in grade. Example: <Decode Grade="4.0"/>
Quiet Zone	Quiet Zone. Value in grade. Example: <QuietZone Grade="4.0"/>
Global Threshold	The reflectance level midway between the maximum and minimum reflectance values in a scan reflectance profile used for the initial identification of elements. Example: <GlobalThreshold>41.0%</GlobalThreshold>
Print Contrast Signal	Print Contrast Signal (PCS) in percentage Example: <PCS>97.0%</PCS>
Average Bar Gain	Average bar gain in percentage Example: <BarGain>3.0%</BarGain>

# Summary Report

Summary report is generated based on the individual report's label ID range exported by the user. For example, user exported individual report starting from label ID, 1000 to 2000, then the summary report will be generated based on data in the individual report for label ID from 1000 to 2000.

Content	Description
Summary ID	Summary report ID Example: <Summary ID="1000_2000">
Total Number	Total number of individual reports created based on the input range. This number includes the retry report. Example: <TotalNumber>1000</TotalNumber>
Failed Number	Number of failed individual reports Example: <FailedNumber>2</FailedNumber>
Failed Rate	Failure rate in percentage Example: <FailedRate>0.2%</FailedRate>
Failed Label Details	Failed label details Example: <FailLabel Retry="0" PrintJob="13" LabelID="14">
Summary ID	Summary report ID Example: <Summary ID="1000_2000">

## Restore Default Verification Files

You can restore the default verification database and remove all failed label image files in order to free up the memory through the following interfaces:

- PrintSet
- Web page
- LCD

To restore the default verification database:

1. Go to **Webpage > Services > Restore Defaults > Verification Files**
2. Click **Restore**.
3. Restart the printer.

## Fingerprint Command

To show verification results/record summary on standard I/O or label after the last verification database been reset.

VERIFIER RESULT [PRINT]

Argument	Description
PRINT	To print the summary on the label

Send this command to retrieve summary of verification results. A typical result might be:

- Verified: 104 labels
- Failed: 3 labels
- Failure Rate: 2.9%

To get the summary printed on the label:

**VERIFIER > RESULT > PRINT**





## System Information

Look in the **System Information** tab on the printer web page for useful information and statistics on the printer hardware and firmware.

## Statistics

Use the printer web page to view important statistics about your printer.

Statistic Type	Information Available
System Information	Printer uptime and CPU usage, firmware and kernel versions, printer configuration and serial numbers, flash and RAM memory information
Supply	Printhead and ribbon information
Hardware Options	Input/output devices, serial port information
Network Interfaces	MAC address, TCP/IP, Bluetooth, and 802.11 network information
Font Information	Name, type, location, and size of installed fonts
Bar Code Information	Name and type of installed bar code fonts
Image Information	Name, type, location, and size of installed images

1. Open a web browser on your PC.
2. In the address bar, type the IP address of your printer and press **Enter**. The printer web page appears.
3. Click the **System Information** tab.
4. Click **Statistics > System Information**. The System Information page appears.
5. For more detailed statistics, click another choice in the Statistics list.

# Printer Odometer

You can check the odometer from the printer web page to see the printhead usage and how the current values compare to the alert values.

**Note:** *To check the printer odometer from the web page, the printer must be turned on and connected to your network.*

1. Open a web browser on your PC.
2. In the address bar, type the IP address of your printer and press **Enter**. The printer home page appears.
3. Click the **System Information** tab.
4. Select **Odometer**. The list of current odometer statistics appears.

# Maintenance Alerts

To help maintain the printer, you can configure the printer to send alert messages when certain conditions occur. For example, the printer can send a message when the odometer reaches a certain value, or if the printhead is lifted during printing.

There are three types of alerts:

- Error alerts
- Information alerts
- Warning alerts

You configure alert settings in the printer web page. Alert messages can be sent to an email address, an SNMP trap, or both. You can enable or disable each type of alert, set the number of times the alert is repeated, set the unit of measure that determines how often the alert is sent, and change the default text message for the alert.

# Set Alerts

You can set maintenance alerts to determine the threshold or value at which an alert is sent to you

1. Open a web browser on your PC.
2. In the address bar, type the IP address of your printer and press **Enter**. The printer web page appears.
3. Click **Login**. The Login page appears.
4. Type your Username and Password and then click Login. The default value for Username is **itadmin** and the default value for Password is **pass**.
5. Click the **Configure** tab. The Configuration Summary page appears.

6. Click **System Settings > Maintenance Alerts**. The Maintenance Alerts settings page appears.
7. Type the values you want to set for each maintenance alert.
8. Click **Save** when you are finished.

## Alert Notifications

The way you receive error alerts is determined by the notification method you configure. You can choose between receiving notifications by SNMP trap, email, or SNMP trap + email.

- From the printer Main Menu, select **Settings > System Settings > General > Alert Notification Method**.

Or

- From the printer web page, login and then click the **Configure tab > System Settings > General > Alert Notification Method**.

## Error Alerts and Solutions

Use these tables to understand and troubleshoot some common error alerts you may receive and how to fix them.

Error Alert	Solution
Label Not Taken	Printing has been stopped because a label is obstructing the label taken sensor. Remove the label to resume printing or try LTS sensor calibration to clear this error.
Printhead Lifted	Lower the printhead.
Front Arm Lifted	Lower Front Arm
Out of Ribbon	Load ribbon in the printer.
Out of Media	Load media in the printer.
Ribbon Low	The diameter of the remaining roll of media is lower than the specified value in the Ribbon Low Diameter setting. Replace the ribbon.
Media Low	The diameter of the remaining roll of media is lower than the specified value in the Media Low Diameter setting. Replace the media.
Ribbon Installed	The printer is configured as a direct thermal printer and thermal transfer ribbon is installed. Remove the ribbon or configure the printer for thermal transfer media.
Printer in Pause Mode	A print job is paused from the front panel. Press the <b>Print</b> button to resume printing.
Printer in Menu Mode	A user entered a menu from the front panel. Press the <b>Home</b> button to return to the Ready screen.
Application Break	Fingerprint only. An application breaks uncontrolled.
Print Job Complete	A print job has been successfully completed.
Odometer (Printer)	The printer has reached a limit set in the Odometer (Printer) setting in Maintenance Alerts for the amount of media to print before being alerted.
Odometer (Printhead)	The printhead has reached a limit set in the Odometer (Printhead) setting in Maintenance Alerts for the amount of media to print before being alerted.
Odometer (User Resettable)	The printer has reached a limit set in the Odometer (User Resettable) setting in Maintenance Alerts for the amount of media printed since the last reset.
Printhead Too Hot	The printhead is overheated and needs to cool down. Wait for printing to resume automatically.
Printhead Not Detected	The printer is not detecting the printhead. Check to make sure the printhead is installed and that the printhead cable is firmly connected to the printhead.
Faulty Dot	The printhead has reached the number of faulty dots set in the Faulty Dots setting in Maintenance Alerts. You may need to replace the printhead.
Replace Printhead	The printer has reached a limit set in the Replace Printhead setting in Maintenance Alerts for the amount of media to print before replacing the printhead. Replace the printhead.
Clean Printhead	The printer has reached a limit set in the Clean Printhead setting in Maintenance Alerts for the amount of media to print before cleaning the printhead. Clean the printhead.
Upgrading Firmware	The printer is going to start upgrading the firmware. Do not try to send anything to the printer.
Printer is Rebooting	The printer is going to restart. Wait until the printer is ready before attempting to communicate with it.
Started	The printer is in the process of starting up.

## Verifier Error Alerts and Solutions

Error Alert	Solution
Verifier Power Failed	Set the Verifier Settings to READ/NO READ or ISO 15415/15416 Align the calibration card with the tear bar
Calibration Failed	Clean the verifier glass. Make sure that the calibration card is aligned correctly to the tear bar. Check the condition of the calibration card.
Front Arm Lifted	Lower Front Arm
Verification Failed	Check the quality of the printed label. Clean the verifier glass and calibrate the verifier.
Verifier Calibration Required	Calibrate the Verifier using the calibration card
Verifier Hardware Error	Contact support at <a href="http://www.honeywellaidc.com">www.honeywellaidc.com</a>
Unsupported Barcode	No impact on the label verification status. the unsupported barcode will be ignored
Verifier Calibration Expired	Recalibrate the verifier to make sure the ANSI grading conforms to the standard.
Feed Card Failed	Check whether the calibration card is feeding out correctly.
Color Out of Range	Calibration card replacement
Aperture Failed	Contact support at <a href="http://www.honeywellaidc.com">www.honeywellaidc.com</a>
LED Calibration Failed	Check the condition of the calibration card. ALign the calibration card with the tear bar. If the problem persists, contact support at <a href="http://www.honeywellaidc.com">www.honeywellaidc.com</a>

## Troubleshoot Printer Problems and Find Solutions

Use this section to find possible solutions to printer problems.

### Print Quality Problems

Problem	Possible Solution
The printout is weak	Try these possible solutions in order: <ul style="list-style-type: none"> <li>• Make sure that your media &gt; print quality setting is appropriate for hte type of media you are using.</li> <li>• The contrast may be too low. Increase the contrast.</li> <li>• The printhead pressure may be too low. Increase the printhead pressure.</li> <li>• Replace the printhead.</li> </ul>
The printout is weaker on one side	Adjust the printhead balance.

Problem	Possible Solution
There are weak spots on the printout.	Try these possible solutions in order: <ul style="list-style-type: none"> <li>• There may be foreign particles on the media. Clean or replace the media.</li> <li>• Make sure that your media and ribbon are compatible.</li> <li>• Make sure that you are using high quality media and ribbon.</li> <li>• The contrast may be too low. Increase the contrast.</li> </ul>
The printout is dark or there is excessive bleeding on the media	Try these possible solutions in order: <ul style="list-style-type: none"> <li>• Make sure your media &gt; print quality setting is appropriate for the type of media you are using.</li> <li>• The contrast may be too high. Decrease the contrast.</li> <li>• The printhead pressure may be too high. Decrease the printhead pressure.</li> <li>• The printhead voltage may be incorrect or the energy control may be faulty. For help, contact <a href="#">Product Service and Repair</a>.</li> </ul>
There are dark lines along the media path	The printhead may be dirty. Clean the printhead.
There are white vertical lines on the printout	Try these possible solutions in order: <ul style="list-style-type: none"> <li>• The printhead may be dirty. Clean the printhead.</li> <li>• There may be missing dots on the printhead. Replace the printhead.</li> </ul>
Part of a dotted line is missing	Try these possible solutions in order: <ul style="list-style-type: none"> <li>• The printhead may be failing. Replace the printhead.</li> <li>• The strobe signal may be failing. For help, contact <a href="#">Product Service and Repair</a>.</li> </ul>
The inner edge of the printout is missing	Try these possible solutions in order: <ul style="list-style-type: none"> <li>• The media may not be properly installed or aligned. Reload the media.</li> <li>• The media margin or X-start parameter may be set too low. Increase the setting.</li> </ul>
The content on the printout is compressed	The print speed may be too high. Lower the print speed.
Nothing shows up on the thermal transfer printout.	The ink-coated side of the ribbon may not be facing the media. Reload the ribbon.
The ribbon breaks	Try these possible solutions in order: <ul style="list-style-type: none"> <li>• Make sure your media setting is appropriate for the type of media you are using.</li> <li>• Make sure that the ribbon is fitted correctly. Reload the ribbon.</li> <li>• The energy control may be faulty. For help, contact <a href="#">Product Service and Repair</a>.</li> </ul>
The ribbon wrinkles	Try these possible solutions in order: <ul style="list-style-type: none"> <li>• It is possible that the ribbon was not loaded correctly, check the Ribbon Ink In and Ink Out Switch is in the correct position.</li> <li>• Darkness setting may be too high, reduce darkness setting</li> <li>• You may need to adjust the media edge guide and use/adjust the Media roll holder.</li> <li>• Incorrect or uneven print head pressure, adjust Print head Pressure and Toggle Position.</li> <li>• Adjust the ribbon tension bar, turn the tension bar screw clockwise to move the bar lower and decrease the tension. turn the tension bar screw counterclockwise to move the bar upper and increase the tension.</li> </ul>

<b>Problem</b>	<b>Possible Solution</b>
The printer is connected to the PC using a virtual COM port and printing stops. There are no errors.	Make sure that bidirectional support is disabled. From the printer properties dialog box, click the <b>Ports</b> tab, and then clear the <b>Enable bidirectional support</b> check box.
The printer is connected to a serial port on the PC but the printer is not working.	Try these possible solutions: <ul style="list-style-type: none"> <li>• Make sure the serial port settings are configured correctly.</li> <li>• Make sure the serial cable pinouts are correct and that the cable is not damaged.</li> <li>• If you have the Windows driver for an RS-232 printer installed on your PC, uninstall the driver.</li> </ul>

## Verifier Problems

<b>Problem</b>	<b>Possible Solution</b>
Inconsistent barcode grading	Avoid interfering with the printed media during verification
Poor grading	Clean the verifier glass and printhead Calibrate the verifier
Voiding good labels	Adjust the verification passing grade
Verifier is not functioning	Check if the license is installed Check if the verification type is set to Read/No Read or ISO 15415/15416
Low reflectance/low grading	Try these possible solutions in order: <ul style="list-style-type: none"> <li>• Make sure that your print quality setting is appropriate for the type of media that you are using.</li> <li>• The contrast may be too low; increase the contrast</li> <li>• The printhead pressure may be too low; increase printhead pressure</li> </ul>
Minimum Edge Contrast low grading	Use a lighter, non-glossy media Increase barcode size-X dimension
Symbol contrast low grading	Try these possible solutions in order: <ul style="list-style-type: none"> <li>• The contrast may be too low; increase contrast</li> <li>• The printhead pressure may be too low; increase printhead pressure</li> <li>• Use non-glossy media</li> </ul>
Modulation low grading	Use a lighter, non-glossy media Increase barcode size-X dimension
Defects low grading	Try these possible solutions in order: <ul style="list-style-type: none"> <li>• Make sure that your print quality setting is appropriate for the type of media that you are using.</li> <li>• The contrast may be too low; increase the contrast</li> <li>• The printhead pressure may be too low; increase printhead pressure</li> <li>• There may be foreign particles on the media. Clean or replace the media</li> <li>• The printhead may be dirty. Clean the printhead.</li> </ul>
Decodability low grading	Make sure that your print quality setting is appropriate for the type of media that you are using.

# Networking Problems

Problem	Possible Solution
The Ethernet or wireless network connection is not working correctly	Try these possible solutions: <ul style="list-style-type: none"><li>• Make sure your network cable is securely connected to your printer and a straight pin-to-pin cable, not a crossover cable.</li><li>• Make sure your PC is correctly configured for and connected to your network.</li><li>• Make sure your printer is correctly configured for your network.</li></ul>
I can't connect to the printer web page	If you are connecting your printer with a crossover network cable, you may need to disable the web browser's proxy settings on your computer to access the printer web page.

## Restore Printer Defaults

To restore factory defaults on the printer, use the printer web page or the Main Menu on the full touch printer. From the printer web page and the Main Menu on a full touch printer, you can choose to restore default network settings, keep or delete user-installed files, and to restore all system settings.

## Restore Defaults from the Printer Web Page

Restore your printer's defaults from the printer web page if you are connected to a WiFi or Ethernet network.

1. Start a web browser on your desktop PC.
2. In the address field, type the printer IP address and press **Enter**. The printer web page appears.
3. Click **Login** in the upper right corner of the screen. The Login page appears.
4. Type your Username and Password in the text fields and click **Login**.
5. Select **Services > Restore Defaults**. The Restore Defaults menu appears with none of the check boxes selected.
6. To restore all default settings, select all of the check boxes and then click **Restore**. You can also restore only the defaults for specific settings:
  - To restore the current network settings, select the **Network settings** check box.
  - To restore all applications, fonts, and other files you have installed on the printer, select the **User files** check box.
  - To restore all current system settings, select the **System Settings** check box.
7. When you receive a message to reboot the printer on your desktop PC, click **OK** and restart the printer.



## Restore Defaults from the Main Menu

Restore a full touch printer's defaults from the **Tools** menu.

1. From the Ready screen, open the Main Menu.
2. Select **Tools > Restore Defaults**. The Restore Defaults menu appears with all items in the list selected by default.
3. To restore all default settings, continue with the next step. You can also change the settings that are restored as follows:
  - To keep the current network settings, clear the **Network settings** check box.
  - To keep all applications, fonts, and other files you have installed on the printer, clear the **User files** check box.
  - To keep all current system settings, clear the **System Settings** check box.
4. Tap the right arrow and, when prompted, tap **Yes** to restore default settings and reboot. A confirmation message appears.
5. To return to the Main Menu without restoring the default settings, select **No**. To return to the Restore Defaults list without restoring any defaults, select **Cancel**.

## Restore Defaults with a Hardware-Based Reset

Restore the printer defaults on a full touch printer by performing a hardware-based reset.

1. Turn the printer off and open the media cover.
2. Turn the printhead lift lever counterclockwise to raise the printhead.
3. Turn the printer on while pressing and holding the **Feed** button.
4. Release the Feed button when the status bar is nearly full.
5. All of the settings are restored on the printer.
6. Turn the printhead lift lever clockwise to lower the printhead and close the media cover.

## Upgrade the Printer Firmware

Check for periodic updates to the printer firmware. The latest version of the firmware is available from the Honeywell Technical Support Downloads portal (<https://hsmftp.honeywell.com>). Go to **Software > Printers > Printer Drivers > Intermec Windows driver**.)

You can upgrade the printer firmware using:

- The printer web page
- A USB storage device

- PrintSet 5

**Note:** After you upgrade the printer firmware, restore the default settings and calibrate the media sensors.

## Upgrade Firmware from the Printer Web Page

1. Start a web browser on your desktop PC.
2. In the address field, type the printer IP address and press **Enter**. The printer web page appears.
3. Click **Login** in the upper right corner of the screen. The Login page appears.
4. Type your Username and Password in the text fields and click **Login**.
5. Click the **Services** tab and select **Firmware Upgrade**. The Firmware Upgrade screen appears, showing the current firmware version.
6. Click **Browse** to locate the upgrade file. Select it and click **Open**.
7. Click **Upgrade**. The printer web page shows that it is upgrading firmware on your printer.

## Upgrade Firmware from a USB Storage Device

Place the upgrade file in the root directory on the USB storage device.

**Note:** For best results, use a USB storage device that contains no other files besides the upgrade file.

1. Copy the firmware upgrade file to the root directory of the USB storage device.
2. Turn the printer off.
3. Insert the USB storage device into a USB host port.
4. Restart your printer. An upgrading firmware message appears as the upgrade file is loaded into the printer memory. This process may take a few minutes.
5. Remove the USB storage device.

## Clean the Printer

To properly maintain the printer, you should clean it regularly. You can clean these parts of the printer:

- The printhead
- The media guides
- The exterior of the printer

**Caution:** To avoid possible personal injury or damage to the printer, never insert any pointed or sharp objects into the printer.



**Caution:** Use only the cleaning agents specified in this section. Honeywell is not responsible for damage caused by any other cleaning materials used on this printer.

**Caution:** Isopropyl alcohol is a highly flammable, moderately toxic, and mildly irritating substance.

Follow these guidelines for cleaning the printer:

- Always remove the power cord before cleaning.
- Never spray the printer with water. Protect it from water when cleaning the premises.

## Clean the Printhead

Cleaning the printhead on a regular basis is important for the life of the printhead and for the print quality. Clean the printhead each time you replace the media. Follow this procedure to clean the printhead using the cleaning card. If you need to clean additional residue from the platen roller or tear bar, use a cotton swab moistened with isopropyl alcohol.



**Caution:** Never use any sharp tools for removing stuck labels. The printhead and rollers are delicate.

1. Turn the printer off and disconnect the printer from power.
2. Open the media cover.
3. Remove the media and ribbon (if installed).
4. Insert most of the cleaning card under the printhead, and then lower the printhead.
5. Pull out the cleaning card and raise the printhead.
6. Wait for approximately 30 seconds to allow the cleaning fluid to dissolve the residue.
7. Repeat Steps 4 through 6 if necessary.
8. If necessary, clean residue from the platen roller or tear bar with a cotton swab moistened with isopropyl alcohol.
9. Once the parts are dry, replace the media (and ribbon) in the printer.
10. Close the media cover, reconnect power, and turn on the printer.

## Clean the Front Sensor (PX940A)

Both the upper and lower of front sensor are transparent to allow light to pass between the two parts of the label gap and label mark sensors. It is important to keep these surfaces free of dust, stuck labels, and adhesive residue.

1. Turn the printer off and disconnect the printer from power.
2. Open the media cover.
3. Lift up the front sensor arm and clean both the upper and lower of front sensor with a soft, lint-free cloth soaked in isopropyl alcohol.
4. Once the parts are dry, close the front sensor.

## Clean the Verifier (PX940V)

Cleaning the verifier on a regular basis to accurately verify the barcode. It is important to keep the verifier surfaces free of dust, stuck labels, and adhesive residue.

1. Turn the printer off and disconnect the printer from power.
2. Open the media cover.
3. Lift up the verifier and clean the glass with a soft, lint-free cloth soaked in isopropyl alcohol.
4. Once the parts are dry, close the verifier.

## Clean the Media Path

Both the upper and lower media guides are transparent to allow light to pass between the two parts of the label gap and label mark sensors. It is important to keep these surfaces free of dust, stuck labels, and adhesive residue.

1. Turn the printer off and disconnect the printer from power.
2. Open the media cover.
3. Remove the media and ribbon (if installed).
4. Insert a cleaning card or a soft cloth soaked in isopropyl alcohol between the two media guides to clean them.
5. Wait for approximately 30 seconds to allow the cleaning fluid to dissolve the residue.
6. Once the parts are dry, replace the media (and ribbon) in the printer.
7. Close the media cover, reconnect power, and turn on the printer.

## Clean the Exterior of the Printer

Keep the exterior of the printer clean. Maintaining a clean exterior will reduce the risk of dust or foreign particles reaching the inside of the printer and affecting printer function.

Use a soft cloth moistened with water or a mild detergent when cleaning the printer exterior. Keep the surface surrounding the printer clean as well.

## Replace the Printhead

You need to replace the printhead periodically when it wears out due to the rapid heating and cooling process used during printing. How often you need to replace the printhead depends on factors such as what type of images you print, the type of media or ribbon you use, the amount of energy to the printhead, the print speed, and the ambient temperature of the room you print in. The firmware detects the new printhead when you restart the printer.

1. Turn the printer off and disconnect the printer from power.
2. Open the media cover.
3. Remove the media and ribbon (if installed).
4. Turn the printhead lift lever counterclockwise to raise the printhead.
5. Pull down the Front Sensor(PX940A)/Verifier(PX940V).
6. Move the inside toggle and outside toggle to the center of printhead.
7. Use the screw driver to loose the left and right screws.

8. Disconnect the two cables from the printhead as you remove it from the printer.
9. Connect the two printhead cables to the new printhead.
10. Insert the new printhead to the bracket into the printer.
11. Fasten the left and right screw.
12. Lock the Front Sensor(PX940A)/Verifier(PX940V) module back to the printer.
13. Replace the media (and ribbon) in the printer.
14. Turn the printhead lift lever clockwise to lower it.
15. Close the media cover, reconnect power, and turn on the printer.

## Replace the Platen Roller

If the printer platen roller gets damaged or wears out, it may need to be replaced.

1. Turn the printer off and disconnect the printer from power.
2. Open the media cover.
3. Remove the media.
4. Turn the printhead lift lever counterclockwise to raise the printhead.

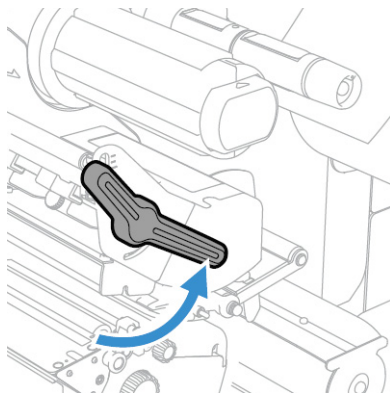

5. Pull out the verifier or front sensor locker toward the outside.
6. Pull down the front sensor (on PX940A model) or the verifier module (on PX940V model) toward the front side.

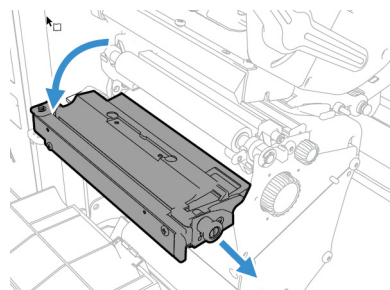

7. Rotate the platen roller latch clockwise to detach it from the printer and pull the platen roller away from the printer.

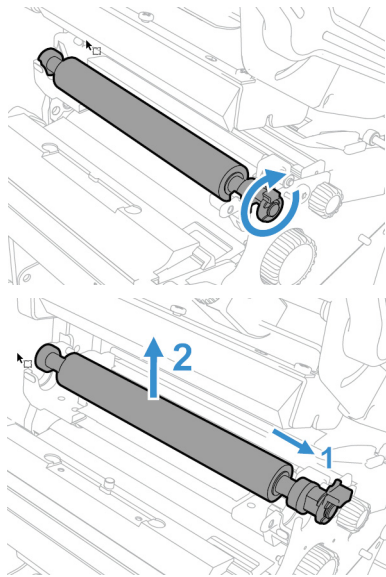

8. Insert the new platen roller and slide it into the printer.
9. Lock the platen roller by rotating the latch clockwise.

## Printhead Pressure and Toggle Adjustment

Your printer may need to be adjusted to accommodate how you are printing or to improve printer performance.

### Pressure Adjustment

You may need to adjust the printhead pressure on the printer if:

- You are using thicker or thinner media than previously used
- Labels are printing lighter on one side than the other
- The thermal transfer ribbon starts to crease

**Note:** Do not use a higher printhead pressure than necessary, it may increase the wear on the printhead and shorten its life.

For more information, see [Printhead Pressure and Toggle Position](#), beginning on page 19.

## Label Taken Sensor Calibration

If your printer has the optional label taken sensor or the label dispenser (which includes the sensor), use the wizard to calibrate the sensor for your media.

**Note:** For best results, calibrate the sensor each time you load media or move the printer to a different environment. If you installed the label taken sensor module or the label dispenser in the printer, calibrate the sensor before you begin printing.

Before you calibrate the sensor, load media and ribbon in the printer as necessary.

1. In the Main Menu, select **Wizards > Calibration > Label Taken Sensor**.
2. Follow the prompts to calibrate the sensor.

## Label Gap and Black Mark Sensor Adjustments

The label gap sensor is a transmissive sensor that controls how the printer feeds media by detecting gaps between the labels. The black mark sensor is a reflective sensor that detects black marks on continuous media.

The sensor contains a blue LED that is strong enough to see through media. You can use the blue LED to help determine the proper location for the sensor.

1. Open the media cover.
2. Adjust the label gap and black mark sensor:
  - Turn the sensor adjustment knob counterclockwise to move the sensor toward the outside of the printer.
  - Turn the sensor adjustment knob clockwise to move the sensor toward the inside of the printer.

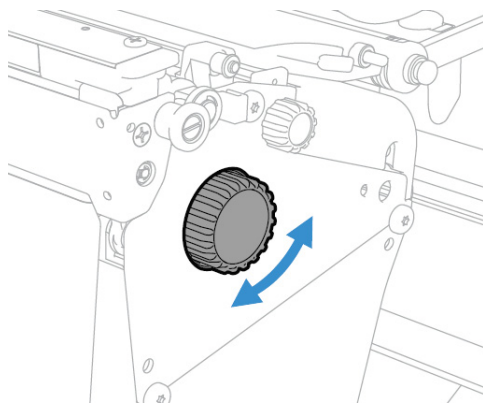

3. Close the media cover.



## Printer and Environmental Specifications

1. Go to [www.honeywellaidc.com](http://www.honeywellaidc.com).
2. Navigate to PX940 product page.
3. Locate the **Products** tab.
4. Click on your printer model.
5. Select one of the following tabs:
  - **Specifications**  
Printer specifications are listed here.
  - **Documents**  
Download the Data Sheet, Quick Start Guide, User Guide, Regulatory Information, and other product documentation.

## Supported Command Languages

- Autosense
- Fingerprint
- Direct Protocol
- Intermec Printer Language (IPL)
- ZSim
- DSim
- Smart Printing

## Media Sensors

- Label gap/tag notch
- Black mark
- Printhead lift

- Media low (with rotational hanger option)
- Ribbon present/end (thermal transfer models only)
- Ribbon end
- Ribbon low

## Network Services

- FTP
- HTTP Server
- SNMP v1/2c/3
- SNMP client support for IPv4 and IPv6
- WINS for IPv4
- BOOTP for IPv4
- DNS client support for IPv4 and IPv6
- Line Printer Protocol
- Raw TCP (Telnet in/out)
- DHCP client for IPv4 and IPv6 network (dual stack)
- IPv4 and IPv6
- Ping
- IPSEC/IKEv2 over IPv6
- SSH
- Time Server

## Fonts

### Resident Fonts

- Andale Mono
- Andale Mono Bold
- CG Times
- CG Times Bold
- CG Triumvirate Condensed Bold
- Century Schoolbook Roman
- Dutch 801 Roman
- EPL203FNT1
- EPL203FNT2

- EPL203FNT3
- EPL203FNT4
- EPL300FNT1
- EPL300FNT2
- EPL300FNT3
- EPL300FNT4
- EPL300FNT5
- Honeywell Sans TT Bold
- IPLFNT0H
- IPLFNT1H
- IPLFNT20
- IPLFNT20H
- IPLFNT21
- IPLFNT21H
- IPLFNT22
- IPLFNT23
- IPLFNT23H
- IPLFNT24
- IPLFNT24H
- IPLFNT2H
- IPLFNT30
- IPLFNT30H
- IPLFNT31
- IPLFNT31H
- IPLFNT32
- IPLFNT32H
- IPLFNT33
- IPLFNT33H
- IPLFNT34
- IPLFNT34H
- IPLFNT35
- IPLFNT36
- IPLFNT37
- IPLFNT7H
- IPLFONT0

- IPLFONT1
- IPLFONT2
- IPLFONT7
- Letter Gothic
- MHeiGB18030C-Medium
- Monospace 821
- Monospace 821 Bold
- OCR A
- OCR B
- Univers
- Univers Bold
- Univers Condensed Bold
- Univers Extra Condensed

## Downloadable Fonts

For broader language and character support, any Unicode TrueType or TrueType-based OpenType font may be downloaded. Fonts from Monotype Imaging are recommended to address global languages. The fonts below have been tested and are available for purchase and download at [www.fonts.com](http://www.fonts.com).

WorldType Collection fonts support all global languages whereas the other fonts listed support specific languages.

- Angsana New Regular
- Helvetica World
- MSung PRC Medium
- MSung HK Medium
- HYGothic-Medium
- TBMInPro-Light
- NarkisClassicMF
- WorldType Collection J
- WorldType Collection K
- WorldType Collection S
- WorldType Collection T

## Supported Font Types

- TrueType
- OpenType
- Bitmap

# Bar Code Symbologies

## 1D Bar Code Symbologies

- Codabar
- Code 11
- Code 39
- Code 93
- Code 128
- DUN-14/16
- EAN
- HIBC 39
- HIBC 128
- Industrial 2 of 5
- Interleaved 2 of 5
- ISBT-128
- Matrix 2 of 5
- Straight 2 of 5
- UPC

## 2D Bar Code Symbologies

- Aztec
- Code 16K
- Code 49
- Data Matrix
- DotCode
- Grid Matrix
- MaxiCode
- MicroPDF417
- MSI (modified Plessey)
- PDF417
- Planet Code
- Plessey Code
- Postnet
- QR Code
- RSS-14
- USPS 4-State Customer Bar Code

## Graphic File Types

- PCX
- PNG
- GIF
- BMP

# DEFAULT SETTINGS

Use this appendix to view the printer's factory default settings.

## Communications Settings

### Serial Port

The printer must be connected to the PC through a serial port to view the settings:

- From the printer Main Menu, select **Settings > Communications > Serial > COM1**.
- From the printer web page, click the **Configure** tab. Go to **Communications > Serial**.

Serial Port Setting	Description	Default
Baud Rate	Transmission speed in bits per second (bps) for the serial port.	115200
Data Bits	Number of bits that define a character or byte.	8
Parity	Specifies how the printer checks the integrity of the transmitted data.	None
Stop Bits	Number of bits sent at the end of every character to allow the receiving signal hardware to detect the end of a character and to resynchronize with the character stream.	1
Hardware	Specifies if hardware flow control (RTS/CTS) is used to manage the rate of data transmission between the device and the host.	Disable
ENQ/ACK	Specifies if software flow control (ENQ/ACK) is used to manage the rate of data transmission between the device and the host.	Disable
XON/XOFF To	Specifies if software flow control (XON/XOFF) is used to manage the rate of data transmission to the host.	Disable
XON/XOFF From	Specifies if software flow control (XON/XOFF) is used to manage the rate of data transmission from the host.	Disable
New Line Character	Defines the characters that the printer echoes to the host to indicate that it has moved to a new line.	CR/LF

# Ethernet

To view these settings:

- From the printer Main Menu, select **Settings > Communications > Ethernet**.
- From the printer web page, click the **Configure** tab. Go to **Communications > Ethernet**.

<b>Ethernet Setting</b>	<b>Description</b>	<b>Default</b>
(IPv4) IP Assignment Method	Specifies how the printer obtains an IP address.	DHCP
(IPv4) IP Address	Specifies the unique network-level address that is assigned to each device in a TCP/IP network (IPv4).	0.0.0.0
Subnet Mask	Specifies a number that defines the range of IP addresses that can be used in a TCP/IP network.	0.0.0.0
Default Router	Specifies the IP address of a router that is used when a device sends a packet to another subnet or to an unknown destination.	0.0.0.0
DHCP Response	Specifies if the printer receives DHCP responses by broadcast or unicast.	Broadcast
(IPv6) IP Assignment Method	Specifies how the printer obtains an IP address (for IPv6 networks).	Automatic
(IPv6) IP Address	Specifies the unique network-level address that is assigned to each device in a TCP/IP network (IPv6).	Automatic

# Bluetooth Settings

To view these settings:

- From the printer Main Menu, select **Settings > Communications > Bluetooth**.
- From the printer web page, click the **Configure** tab. Go to **Communications > Bluetooth**.

<b>Bluetooth Setting</b>	<b>Description</b>	<b>Default</b>
Device Name	Sets the name that identifies the printer in the Bluetooth network. Maximum length is 16 characters.	Printer model number and serial number.



# Media Settings

To view these settings:

- From the printer Main Menu, select **Settings > Printing > Media**.
- From the printer web page, click the **Configure** tab. Go to **Printing > Media**.

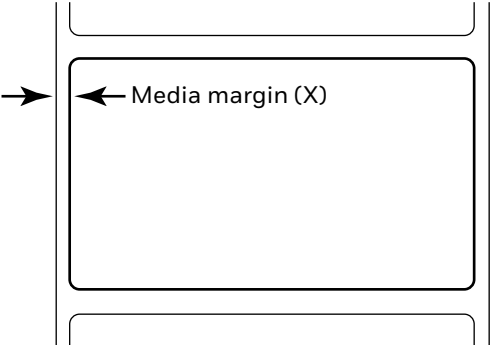
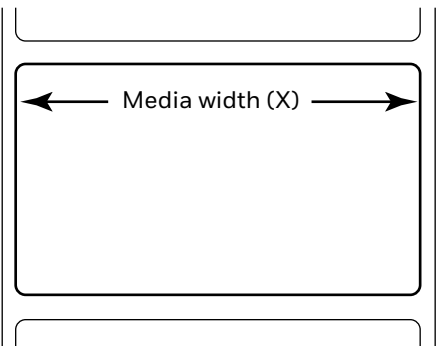
Media Setting	Description	Default
Media Type	Selects the type of media that is loaded in the printer.	Media With Gaps
Print Method	Selects the method of printing that the printer is using.	Ribbon (TTR) for thermal transfer printers, or No Ribbon (DT) for direct thermal printers
Media Margin (X)	<p>Sets the width of the margin from the left edge of the label along the printhead to the edge of the printable area. Unit of measurement is defined in the Unit of Measurement parameter.</p>  <p>The diagram shows a rectangular label with a smaller inner rectangle representing the printable area. A horizontal double-headed arrow labeled 'Media margin (X)' spans the distance from the left edge of the label to the left edge of the printable area. An external arrow points to the left edge of the label.</p>	Variable
Media Width	<p>Sets the width of the printable area measured from the media margin (X) across the printhead. Unit of measurement is defined in the Unit of Measure parameter.</p>  <p>The diagram shows a rectangular label with a smaller inner rectangle representing the printable area. A horizontal double-headed arrow labeled 'Media width (X)' spans the width of the inner rectangle, starting from its left edge and ending at its right edge.</p>	Variable

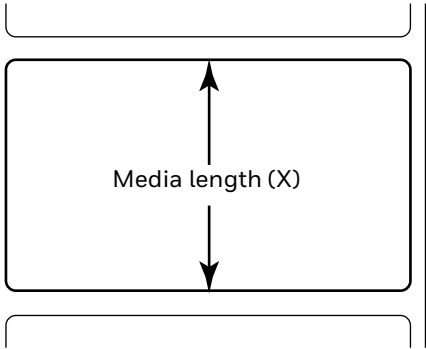
Media Setting	Description	Default
Media Length	<p>Sets the length of the printable area measured from one edge of the label to the edge that is closest to the printhead. Unit of measurement is defined in the Unit of Measurement parameter.</p> 	Variable
Clip Default	<p>Determines if the printer prints items outside the printable area of the label. When this is set to <b>Off</b>, the printer returns an error if any part of a bar code label cannot be printed because that part extends beyond the printable area. When this is set to <b>On</b>, the printer prints all bar code labels, but may also print unreadable, incomplete labels.</p>	Off
Print Mode	Selects the printer tear off, peel off, or rewind media mode	Tear Off
Peel Strength	Selects strength the printer uses to peel the label off from liner. Use Medium or High if the printer has trouble to peel certain types of media.	Low
Label Top Adjust	Sets the length of media the printer feeds (positive value) or retracts (negative value) before printing a label. Unit of measurement is defined in the Unit of Measure parameter. Range is -9999 to +9999.	0
Label Reset Adjust	Sets the length of media the printer feeds (positive value) or retracts (negative value) after printing a label. Unit of measurement is defined in the Unit of Measure parameter. Range is -9999 to +9999.	0
Media Calibration Mode	Selects the mode the printer uses to calibrate media. Use Slow if the printer has trouble identifying gaps or marks in media. Use Fast with Retraction or Slow with Retraction to retract the media and ribbon fed for calibration back to the printer.	Slow
Length (Slow Mode)	If Media Calibration Mode is set to Slow, the printer prints the media length plus 10 mm. This value sets an additional amount of media to be printed. Unit of measurement is defined in the Unit of Measurement parameter. Range is 0 to 3200.	0
LTS Sensitivity Level	Sets the sensitivity of the label taken sensor.	0

Media Setting	Description	Default
Power Up Action	Sets the action when you turn the printer on: <b>No Action</b> <b>Formfeed:</b> The printer feeds one label. <b>Testfeed:</b> The printer prints two configuration labels as it calibrates the media sensors. <b>Smart Calibration:</b> Detects media type (gap, black mark, or continuous, detects printing method (ribbon or no-ribbon), and calibrates media length.	Smart Calibration
Head Down Action	Sets the action when you close the print mechanism after opening it: <b>No Action</b> <b>Formfeed:</b> The printer feeds one label. <b>Testfeed:</b> The printer prints two configuration labels as it calibrates the media sensors. <b>Smart Calibration:</b> Detects media type (gap, black mark, or continuous, detects printing method (ribbon or no-ribbon), and calibrates media length.	Smart Calibration
Hold Feed Button Action	Sets the action when you press and hold the Print button for more than 2 seconds: <b>Testfeed:</b> The printer prints two configuration labels as it calibrates the media sensors. <b>Smart Calibration:</b> Detects media type (gap, black mark, or continuous, detects printing method (ribbon or no-ribbon), and calibrates media length.	Smart Calibration
Label Counter	Specifies a label counter (from 1 to 49) that SNMP uses to report media counts.	0 (off)

## Print Quality Settings

To view these settings:

- From the printer Main Menu, select **Settings > Printing > Print Quality**.
- From the printer web page, click the **Configure** tab. Go to **Printing > Print Quality**.

Print Quality Setting	Description	Default
Print Speed	Sets how fast the printer prints labels. The unit of measure is defined in the Unit of Measure parameter.	200dpi:100 300dpi:100 600dpi: 50
Media Sensitivity	Sets the level of sensitivity of the media to the printhead heat for media and ribbon.	High
Darkness	Sets the image darkness for media and ribbon. Adjust this parameter with the Media Sensitivity parameter. Range is 1 to 100.	55
Contrast	Adjusts the blackness of the printing on the label in 2% increments from -10% to +10%.	+0%

# System Settings

## General System

To view these settings:

- From the printer Main Menu, select **Settings > System Settings > General**.
- From the printer web page, click **Configure > System Settings > General**.

General System Setting	Description	Default
System Name	Sets the network identification name (WINS name) of the printer.	Printer model number and serial number.
System Location	Sets the location of the printer.	Empty string
System Contact	Sets the name of the printer administrator.	Empty string
XML Response Mode	Determines if the printer provides XML responses to printing requests (over Telnet and HTTP).	False
Display Language	(LCD printers only.) Selects the language the printer uses to display text on the screen.	English
Display Language (Web Page)	Selects the language the printer uses to display text on the web page.	English
Keyboard Input	Selects the language of the external keyboard that is connected to the printer.	U.S./U.K.
Time	Sets the current time.	System time
Date	Sets the current date.	System date
Command Language	Sets the printer command language. If changed, requires restart.	Autosense
Alert Notification Method	Selects how you want the printer to notify you of printer alerts.	SNMP Trap + Email
Unit of Measure	Selects the unit of measure that is used to define several printing parameters.	Dots
Zero with Slash	Determines how the zero character is printed and displayed on the screen. Disable (0) or Enable (Ø).	Disable
Time Zone	Sets the time zone.	(UTC 00:00) Universal Time
DST Adjust	Determines if Daylight Saving Time is automatically adjusted.	Disable

## Display and Audio Settings

To view these settings:

- From the printer Main Menu, select **Settings > System Settings > Display or Audio**.
- From the printer web page, click **Configure > System Settings > Display or Audio**.

Display and Audio Setting	Description	Default
Brightness	Selects the brightness of the printer screen.	Low
Idle Information	Selects the information that appears on the printer screen when it is in Idle mode.	IPv4 address
Time Format	Selects the format used to display time on the printer.	24 Hour
Date Format	Selects the format used to display date on the printer.	dd/mm/yyyy
Menu Access	Determines if the Menu button on the printer web page is accessible.	Enable
PIN	Sets the password that allows access to the Menu button on the printer web page, if the Menu Access parameter is set to Enable With PIN. Range is 4 to 16 characters.	1234
Screen Timeout	Selects how long the printer screen stays on before the screen saver starts.	Disable
Feed Key Access	Determines if the Feed button on the printer keypad is enabled or disabled.	Enable
Information Access	Determines if the information bar on the Main Menu is accessible.	Enable
Volume	Sets the printer volume.	Off

## System I/O

To view these settings:

- From the printer Main Menu, select **Settings > System Settings > Manage I/O**.
- From the printer web page, click **Configure > System Settings > Manage I/O**.

System I/O Setting	Description	Default
Ethernet	Determines if the printer is allowed to communicate using Ethernet communications.	Enable
Wireless 802.11	Determines if the printer is allowed to communicate using its 802.11 radio. Supported only if the optional WiFi+Bluetooth module is installed.	Enable
Bluetooth	Determines if the printer is allowed to communicate using its Bluetooth radio. Supported only if the optional WiFi+Bluetooth module is installed.	Enable
Virtual COM	Determines if you can enable the USB port to be used as a virtual serial port. When you change this setting, you must restart the printer to enable the new setting.	Disable

## System Network Services

**Note:** You will only see **Manage Services** from the menus if you have an Ethernet or Wireless module installed in the printer.

To view these services:

- From the printer Main Menu, select **Settings > System Settings > Manage Services**.
- From the printer web page, go to **Configure > System Settings > Manage Services**.

System Network Service Setting	Description	Default
Web Server	Determines if the web server is enabled in the printer.	Enable
FTP	Determines if the printer can use File Transfer Protocol (FTP).	Enable
Avalanche	Determines if the printer can be managed by Wavelink Avalanche.	Enable
Net1	Determines if the printer can use Telnet to communicate with Fingerprint.	Enable
SNMP	Determines if the printer can use SNMP.	Enable
LPR	Determines if the printer can use the line printer server (LPR) daemon.	Enable
IKEv2	Determines if the printer can use IKEv2.	Disable
SSH	Determines if the printer can use Secure Socket Handling (SSH).	Disable
Telnet	Determines if the printer can use Telnet.	Disable
XML	Determines if the printer can use XML printing.	Enable
Time Server	Determines if the printer uses the Network Time Protocol (NTP) to synchronize its time with a network time server. The default Server Address is <b>ntp0.cornell.edu</b> , and the default Port Number is <b>123</b> .	Disable
Device Management	Determines if the printer can use 9300 TCP/IP port to communicate with HCD.	Disable
Connectivity Agent	Determines if the printer can communicate with Honeywell Cloud on port 10000.	Disable

# Verifier Settings

## Verification Type

Property	Value
Description	Select the verification type to check the barcode. None - No barcode validation Read/No Read - Validate if barcode is readable ISO15415/15416 - Full ANSI grading of barcode
Value	None Read/No Read ISO 15415/15416
Type	List
Default	Read/No Read
Access Level	1
Path	Verification Settings>Verification.Verifiaction Type
Legacy Path	None
Legacy Section	None
Interface	Supported
Fingerprint	Yes
Web Page	Yes
LCD	Yes
SmartSystems	Yes

## Passing Grade

Property	Value
Description	Sets the minimum passing grade for barcode grading. Grade 0.0 (F) is the lowest grade. Grade 1.5 (C) is the default and recommended by ISO standard. Only applied when verification type is set to ISO15415/15416.
Value	4.0 (A) ... 3.5 (A) 3.4 (B) ... 2.5 (B) 2.4 (C) ... 1.5 (C) 1.4 (D) ... 0.5 (D) 0.4 (F) ... 0.0 (F) Note: There will be 41 selections on the list
Type	List
Default	1.5 (C)
Access Level	1
Path	Verification Settings > Verification > Passing Grade
Legacy Path	None
Legacy Section	None
Interface	Supported
Fingerprint	Yes
Web Page	Yes
LCD	Yes
SmartSystems	Yes



# Aperture

Property	Value
Description	Indicates the aperture size (in mils) used for verification. Aperture size will be chosen automatically based on ISO standard. Change only if required by an overriding application.
Value	Automatic 5 6 8 10 12 14 16 18 20
Type	List
Default	Automatic
Access Level	1
Path	Verification Settings > Verification > Aperture
Legacy Path	None
Legacy Section	None
Interface	Supported
Fingerprint	Yes
Web Page	Yes
LCD	Yes
SmartSystems	Yes

# Retries

Property	Value
Description	Sets maximum number of times printer reprints label after verification failure. This setting is only applicable when the Verification Failure Action is set to Void and Reprint
Value	0 1 2 3 4 5
Type	List
Default	1
Access Level	1
Path	Verification Settings > Error Handling > Retries
Legacy Path	None
Legacy Section	None
Interface	Supported
Fingerprint	Yes
Web Page	Yes
LCD	Yes
SmartSystems	Yes

## Verification Failure Action

Property	Value
Description	<p>Indicates action to take when label fails verification.</p> <p>Void and Reprint - Retract and void the failed label, then reprint the failed label. Stop reprint if the maximum retries have been reached.</p> <p>Void and Print Next - Retract and void the failed label, then continue to print the next label.</p> <p>Pause for User Action - Stop the printing once the label verification fails and prompt the user for action to take.</p> <p>Ignore and Continue - No voiding when verification fails. Result is saved and next label is printed.</p> <p>Note: During multiple label printing, printer will void the failed label (plus all printed and yet to be verified labels) in order to keep the good labels in sequence.</p>
Value	<p>Void and Reprint</p> <p>Void and Print Next</p> <p>Pause for User Action</p> <p>Ignore and Continue</p>
Type	List
Default	Void and Reprint
Access Level	1
Path	Verification Settings > Error Handling > Verification Failure Action
Legacy Path	None
Legacy Section	None
Interface	Supported
Fingerprint	Yes
Web Page	Yes
LCD	Yes
SmartSystems	Yes

## Save Failed Label Images

Property	Value
Description	When enabled, the printer saves all failed label images in non-volatile memory. Maximum 100 images can be saved (if memory available). At maximum capacity oldest image file will be replaced by newest.
Value	Enable Disable
Type	List
Default	Enable
Access Level	1
Path	Verification Settings > Error Handling > Save Failed Labels
Legacy Path	None
Legacy Section	None
Interface	Supported
Fingerprint	Yes
Web Page	Yes
LCD	Yes
SmartSystems	Yes

## Void Pattern

Property	Value
Description	Select the void pattern type to mark the failed label.
Value	Diamond Grid
Type	List
Default	Diamond
Access Level	1
Path	Verification Settings > Error Handling > Void Pattern
Legacy Path	None
Legacy Section	None
Interface	Supported
Fingerprint	Yes
Web Page	Yes
LCD	Yes
SmartSystems	Yes

## Maintenance Alerts

To view these settings:

- From the printer Main Menu, select **Settings > System Settings > Maintenance Alerts**.
- From the printer web page, click the **Configure** tab. Go to **System Settings > Maintenance Alerts**.

Maintenance Alerts Setting	Description	Default
Odometer (User Resettable)	Sets the length of media (in meters) that the printer prints before the Odometer (User Resettable) alert is sent, if this alert is configured. Unit of measurement is defined in the Unit of Measure parameter. Range is 0 to 4294967295.	0
Odometer (Printer)	Sets the length of media (in meters) that the printer prints before the Odometer (Printer) alert is sent. Unit of measurement is defined in the Unit of Measure parameter. Range is 0 to 4294967295.	0
Odometer (Printhead)	Sets the length of media (in meters) that the printer prints before the Odometer (Current Printhead) alert is sent, if this alert is configured. Unit of measurement is defined in the Unit of Measure parameter. Range is 0 to 4294967295.	0
Replace Printhead	Sets the length of media (in meters) that the printer prints before the Replace Printhead alert is sent, if this alert is configured. Unit of measurement is defined in the Unit of Measure parameter. Range is 0 to 4294967295.	0
Clean Printhead	Sets the length of media (in meters) that the printer prints before the Clean Printhead alert is sent, if this alert is configured. Unit of measurement is defined in the Unit of Measure parameter. Range is 0 to 4294967295.	0
Faulty Dot	Sets the number of faulty dots on the printhead before the Faulty Dot alert is sent, if this alert is configured. Range is 0 to 4294967295.	0
Media Low Diameter	Sets the minimum diameter of the media roll before the Media Low alert is sent, if this alert is configured. Range is 0 to 200 mm.	0
Ribbon Low Diameter	Sets the minimum diameter of the ribbon roll before the Ribbon Low alert is sent, if this alert is configured. Range is 0 to 200 mm.	0
Memory Low	Sets the minimum percentage of free RAM memory and/or Flash memory before the Memory Low alert (if this alert is configured) is sent. Unit is percentage.	0



# PRINT LABELS WITH INPRINT

## The INPrint Page

The INPrint page features sample web forms you can use to print single labels if you are using the Fingerprint or Direct Protocol Language on your printer. Select a web form from the lists and enter information in the fields for that label. You can then preview and print the label.

The printer firmware includes several predefined label formats. You can also copy your own label formats to the printer and print them from the INPrint page.

## Print INPrint Labels

If the printer is connected to an Ethernet or WiFi network, you can print labels by entering information in a web form. Access the web forms through the printer web page.

1. Open a browser window on your PC.
2. In the location or address bar, type the printer IP address and press **Enter**. The printer web page appears.
3. Click the **INPrint** tab.
4. Select the web form you want to print:
  - If you created the web form yourself, click **Customer Downloaded** and then select the web form in the list.
  - To use one of the Honeywell resident web forms, click **Resident** and then select the web form in the list.
5. Type information in the web form as needed.

To preview the label on screen, click **Preview**. To print the label, click **Print**.





# ACCESSORY INSTALLATION INSTRUCTIONS

## Verifier Calibration Card

Verifier calibration is required to maintain the verifier image scanning performance.

The Verifier calibration card is used to calibrate the verifier and can be included in the box with the PX940V model printer.

## Handling Instructions

- When not in use, keep the calibration card inside its original packaging, away from direct light exposure and stored at room temperature
- Keep calibration card clean.
- Use a dry cloth to remove any dirt if needed.
- Do not bend the card
- Do not perform verifier calibration if the card is damaged.

For more information on how to calibrate the verifier, see [Calibration](#), beginning on page 42.

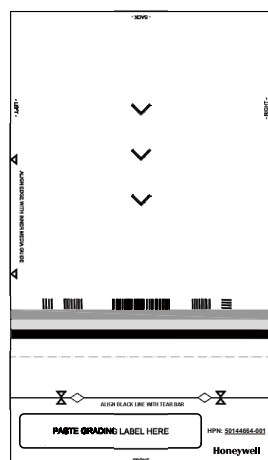





Honeywell  
9680 Old Bailes Road  
Fort Mill, SC 29707

[www.honeywellaidc.com](http://www.honeywellaidc.com)